

mitsubishi

Mitsubishi Programmable Controller

Transition from MELSEC-A/QnA (Large Type) Series to Q Series Handbook

(Intelligent Function Modules)



Sep. 2014 Edition

● SAFETY PRECAUTIONS ●

(Read these precautions before using this product.)

Before using this product, please read this manual and the relevant manuals carefully and pay full attention to safety to handle the product correctly.

In this manual, the safety precautions are classified into two levels: "⚠ WARNING" and "⚠ CAUTION".



Indicates that incorrect handling may cause hazardous conditions, resulting in death or severe injury.



Indicates that incorrect handling may cause hazardous conditions, resulting in minor or moderate injury or property damage.

Under some circumstances, failure to observe the precautions given under "⚠ CAUTION" may lead to serious consequences.

Observe the precautions of both levels because they are important for personal and system safety.

Make sure that the end users read this manual and then keep the manual in a safe place for future reference.

[Design Precautions]

⚠ WARNING

- Configure safety circuits external to the programmable controller to ensure that the entire system operates safely even when a fault occurs in the external power supply or the programmable controller. Failure to do so may result in an accident due to an incorrect output or malfunction.
 - (1) Configure external safety circuits, such as an emergency stop circuit, protection circuit, and protective interlock circuit for forward/reverse operation or upper/lower limit positioning.
 - (2) When the programmable controller detects the following problems, it will stop calculation and turn off all output in the case of (a).
In the case of (b), it will hold or turn off all output according to the parameter setting.
Note that the AnS series module will turn off the output in either of cases (a) and (b).

	Q series module	A series module
(a) The power supply module has over current protection equipment and over voltage protection equipment.	Output OFF	Output OFF
(b) The CPU module self-diagnosis functions, such as the watchdog timer error, detect problems.	Hold or turn off all output according to the parameter setting.	Output OFF

Also, all outputs may be turned on if an error occurs in a part, such as an I/O control part, where the CPU module cannot detect any error. To ensure safety operation in such a case, provide a safety mechanism or a fail-safe circuit external to the programmable controller.

For a fail-safe circuit example, refer to LOADING AND INSTALLATION in the QCPU User's Manual (Hardware Design, Maintenance and Inspection).

- (3) Outputs may remain on or off due to a failure of an output module relay or transistor. Configure an external circuit for monitoring output signals that could cause a serious accident.

[Design Precautions]

WARNING

- In an output module, when a load current exceeding the rated current or an overcurrent caused by a load short-circuit flows for a long time, it may cause smoke and fire. To prevent this, configure an external safety circuit, such as a fuse.
- Configure a circuit so that the programmable controller is turned on first and then the external power supply.
If the external power supply is turned on first, an accident may occur due to an incorrect output or malfunction.
- For the operating status of each station after a communication failure, refer to relevant manuals for each network.
Failure to do so may result in an accident due to an incorrect output or malfunction.
- When changing data of the running programmable controller from a peripheral connected to the CPU module or from a personal computer connected to an intelligent function module or special function module, configure an interlock circuit in the sequence program to ensure that the entire system will always operate safely.
For program modification and operating status change, read relevant manuals carefully and ensure the safety before operation.
Especially, when a remote programmable controller is controlled by an external device, immediate action cannot be taken if a problem occurs in the programmable controller due to a communication failure.
To prevent this, configure an interlock circuit in the sequence program, and determine corrective actions to be taken between the external device and CPU module in case of a communication failure.

CAUTION

- Do not install the control lines or communication cables together with the main circuit lines or power cables.
Keep a distance of 100mm or more between them.
Failure to do so may result in malfunction due to noise.
- When a device such as a lamp, heater, or solenoid valve is controlled through an output module, a large current (approximately ten times greater than normal) may flow when the output is turned from off to on.
Take measures such as replacing the module with one having a sufficient current rating.
- After the CPU module is powered on or is reset, the time taken to enter the RUN status varies depending on the system configuration, parameter settings, and/or program size. Design circuits so that the entire system will always operate safely, regardless of the time.

[Installation Precautions]

CAUTION

- Use the programmable controller in an environment that meets the general specifications in the QCPU User's Manual (Hardware Design, Maintenance and Inspection).
Failure to do so may result in electric shock, fire, malfunction, or damage to or deterioration of the product.
- To mount the module, while pressing the module mounting lever located in the lower part of the module, fully insert the module fixing projection(s) into the hole(s) in the base unit and press the module until it snaps into place.
Incorrect mounting may cause malfunction, failure or drop of the module.
When using the programmable controller in an environment of frequent vibrations, fix the module with a screw.
Tighten the screws within the specified torque range.
Undertightening can cause drop of the screw, short circuit, or malfunction.
Overtightening can damage the screw and/or module, resulting in drop, short circuit, or malfunction.
- When using an extension cable, connect it to the extension cable connector of the base unit securely.
Check the connection for looseness.
Poor contact may cause incorrect input or output.
- When using a memory card, fully insert it into the memory card slot.
Check that it is inserted completely.
Poor contact may cause malfunction.
- Shut off the external power supply (all phases) used in the system before mounting or removing a module. Failure to do so may result in damage to the product. A module can be replaced online (while power is on) on any MELSECNET/H remote I/O station or in the system where a CPU module supporting the online module change function is used.
Note that there are restrictions on the modules that can be replaced online, and each module has its predetermined replacement procedure.
For details, refer to the relevant sections in the QCPU User's Manual (Hardware Design, Maintenance and Inspection) and in the manual for the corresponding module.
- Do not directly touch any conductive part of the module.
Doing so can cause malfunction or failure of the module.

[Wiring Precautions]

WARNING

- Shut off the external power supply (all phases) used in the system before wiring.
Failure to do so may result in electric shock or damage to the product.
- After wiring, attach the included terminal cover to the module before turning it on for operation.
Failure to do so may result in electric shock.

CAUTION

- Individually ground the FG and LG terminals of the programmable controller with a ground resistance of 100Ω or less.
Failure to do so may result in electric shock or malfunction.
- Use applicable solderless terminals and tighten them within the specified torque range.
If any spade solderless terminal is used, it may be disconnected when the terminal screw comes loose, resulting in failure.
- Check the rated voltage and terminal layout before wiring to the module, and connect the cables correctly.
Connecting a power supply with a different voltage rating or incorrect wiring may cause a fire or failure.
- Connectors for external devices must be crimped or pressed with the tool specified by the manufacturer, or must be correctly soldered.
Incomplete connections may cause short circuit, fire, or malfunction.
- Tighten the terminal screws within the specified torque range.
Undertightening can cause short circuit, fire, or malfunction.
Overtightening can damage the screw and/or module, resulting in drop, short circuit, or malfunction.
- Prevent foreign matter such as dust or wire chips from entering the module.
Such foreign matter can cause a fire, failure, or malfunction.
- A protective film is attached to the top of the module to prevent foreign matter, such as wire chips, from entering the module during wiring.
Do not remove the film during wiring.
Remove it for heat dissipation before system operation.
- Mitsubishi programmable controllers must be installed in control panels.
Connect the main power supply to the power supply module in the control panel through a relay terminal block.
Wiring and replacement of a power supply module must be performed by qualified maintenance personnel with knowledge of protection against electric shock.
For wiring methods, refer to the QCPU User's Manual (Hardware Design, Maintenance and Inspection).

[Startup and Maintenance Precautions]

WARNING

- Do not touch any terminal while power is on. Doing so will cause electric shock.
- Correctly connect the battery connector.
Do not charge, disassemble, heat, short-circuit, or solder the battery, or throw it into the fire.
Doing so will cause the battery to produce heat, explode, or ignite, resulting in injury and fire.
- Shut off the external power supply (all phases) used in the system before cleaning the module or retightening the terminal screws or module fixing screws.
Failure to do so may result in electric shock.
Undertightening the terminal screws can cause short circuit or malfunction.
Overtightening can damage the screw and/or module, resulting in drop, short circuit, or malfunction.

CAUTION

- Before performing online operations (especially, program modification, forced output, and operating status change) for the running CPU module from the peripheral device connected, read relevant manuals carefully and ensure the safety.
Improper operation may damage machines or cause accidents.
- Do not disassemble or modify the modules. Doing so may cause failure, malfunction, injury, or a fire.
- Use any radio communication device such as a cellular phone or PHS (Personal Handy-phone System) more than 25cm away in all directions from the programmable controller.
Failure to do so may cause malfunction.
- Shut off the external power supply (all phases) used in the system before mounting or removing a module. Failure to do so may cause the module to fail or malfunction.
A module can be replaced online (while power is on) on any MELSECNET/H remote I/O station or in the system where a CPU module supporting the online module change function is used.
Note that there are restrictions on the modules that can be replaced online, and each module has its predetermined replacement procedure.
For details, refer to this manual and the online module change section in the manual of the module compatible with online module change.
- After the first use of the product, do not mount/remove the module to/from the base unit, and the terminal block to/from the module more than 50 times (IEC 61131-2 compliant) respectively.
Exceeding the limit of 50 times may cause malfunction.
- Do not drop or apply shock to the battery to be installed in the module.
Doing so may damage the battery, causing the battery fluid to leak inside the battery.
If the battery is dropped or any shock is applied to it, dispose of it without using.
- Before handling the module, touch a conducting object such as a grounded metal to discharge the static electricity from the human body. Failure to do so may cause the module to fail or malfunction.

[Disposal Precautions]

CAUTION

- When disposing of this product, treat it as industrial waste.
When disposing of batteries, separate them from other wastes according to the local regulations.
For details on battery regulations in EU member states, refer to the MELSEC-L CPU Module User's Manual (Hardware Design, Maintenance and Inspection).

[Transportation Precautions]

CAUTION

- When transporting lithium batteries, follow the transportation regulations.
(Refer to QCPU User's Manual (Hardware Design, Maintenance and Inspection) for details of the controlled models.)

● CONDITIONS OF USE FOR THE PRODUCT ●

- (1) Mitsubishi programmable controller ("the PRODUCT") shall be used in conditions;
- i) where any problem, fault or failure occurring in the PRODUCT, if any, shall not lead to any major or serious accident; and
 - ii) where the backup and fail-safe function are systematically or automatically provided outside of the PRODUCT for the case of any problem, fault or failure occurring in the PRODUCT.

- (2) The PRODUCT has been designed and manufactured for the purpose of being used in general industries.

MITSUBISHI SHALL HAVE NO RESPONSIBILITY OR LIABILITY (INCLUDING, BUT NOT LIMITED TO ANY AND ALL RESPONSIBILITY OR LIABILITY BASED ON CONTRACT, WARRANTY, TORT, PRODUCT LIABILITY) FOR ANY INJURY OR DEATH TO PERSONS OR LOSS OR DAMAGE TO PROPERTY CAUSED BY the PRODUCT THAT ARE OPERATED OR USED IN APPLICATION NOT INTENDED OR EXCLUDED BY INSTRUCTIONS, PRECAUTIONS, OR WARNING CONTAINED IN MITSUBISHI'S USER, INSTRUCTION AND/OR SAFETY MANUALS, TECHNICAL BULLETINS AND GUIDELINES FOR the PRODUCT.

("Prohibited Application")

Prohibited Applications include, but not limited to, the use of the PRODUCT in;

- Nuclear Power Plants and any other power plants operated by Power companies, and/or any other cases in which the public could be affected if any problem or fault occurs in the PRODUCT.
- Railway companies or Public service purposes, and/or any other cases in which establishment of a special quality assurance system is required by the Purchaser or End User.
- Aircraft or Aerospace, Medical applications, Train equipment, transport equipment such as Elevator and Escalator, Incineration and Fuel devices, Vehicles, Manned transportation, Equipment for Recreation and Amusement, and Safety devices, handling of Nuclear or Hazardous Materials or Chemicals, Mining and Drilling, and/or other applications where there is a significant risk of injury to the public or property.

Notwithstanding the above, restrictions Mitsubishi may in its sole discretion, authorize use of the PRODUCT in one or more of the Prohibited Applications, provided that the usage of the PRODUCT is limited only for the specific applications agreed to by Mitsubishi and provided further that no special quality assurance or fail-safe, redundant or other safety features which exceed the general specifications of the PRODUCTS are required. For details, please contact the Mitsubishi representative in your region.

REVISIONS

* The handbook number is given on the bottom left of the back cover.

Print Date	* Handbook Number	Revision
Apr., 2005	L(NA)-08046ENG-A	First edition
Oct., 2005	L(NA)-08046ENG-B	<p>[Addition]</p> <p>Appendix 1</p> <p>[Partial correction]</p> <p>Contents, Appendix 1 → Appendix 2</p>
Oct., 2008	L(NA)-08046ENG-C	<p>[Model addition]</p> <p>Q64DAN, Q64RD-G, Q68RD3-G, Q68TD-G-H01</p> <p>[Model change]</p> <p>QD62 → QD62-H01, QD62-H02, Q62DA → Q62DAN, Q68DAV → Q68DAVN, Q68DAI → Q68DAIN</p> <p>[Partial correction]</p> <p>Term revision (whole), SAFETY PRECAUTIONS, Chapter 3 (whole), Chapter 4 (whole), Section 6.1 to Section 6.3, Section 7.1, Section 9.1.2, Section 9.1.4, Appendix 2.1 to Appendix 2.3</p>
Jul., 2011	L(NA)-08046ENG-D	<p>[Model addition]</p> <p>Q68AD-G, Q68TD-G-H02</p> <p>[Partial addition]</p> <p>CONDITIONS OF USE FOR THE PRODUCT, Section 2.4, Section 2.6, Section 2.8</p> <p>[Partial correction]</p> <p>Term revision (whole), SAFETY PRECAUTIONS, Chapter 3 (whole), Chapter 4 (whole), Section 5.1.1, Section 5.2.1, Section 6.1, Section 6.2.1, Section 7.1, Section 7.4.1, Section 7.4.4, Section 7.5.1, Section 7.5.4, Chapter 9, Appendix 2.1, Appendix 2.3</p> <p>[Partial deletion]</p> <p>Chapter 9 (External dimensions)</p>
Mar., 2013	L(NA)-08046ENG-E	<p>[Model addition]</p> <p>QD73A1</p> <p>[Model change]</p> <p>QD75P□ → QD75P□N, QD75D□ → QD75D□N</p> <p>[Addition]</p> <p>Section 7.6</p> <p>[Partial correction]</p> <p>Section 2.4.4, Section 2.6.1, Section 2.8.1, Section 3.1, Section 4.6.1, Section 6.1, Section 6.3.4, Section 7.1, Section 7.2, Section 7.4</p>

* The handbook number is given on the bottom left of the back cover.

Print Date	* Handbook Number	Revision
Jun., 2013	L(NA)-08046ENG-F	<div data-bbox="619 248 790 277" style="border: 1px solid black; padding: 2px;">Partial correction</div> Section 4.1, Section 6.2.1, Section 6.3.1, Section 7.1, Section 7.4.4, Section 7.5.4, Section 7.6.4, Section 7.6.6
Sep., 2014	L(NA)-08046ENG-G	<div data-bbox="619 378 790 407" style="border: 1px solid black; padding: 2px;">Partial correction</div> Section 2.1, Section 3.1, Section 4.1, Section 5.1, Section 6.1, Section 7.1, Section 7.2, Section 7.3, Section 7.5.5, Appendix 2.1

Japanese Handbook Version L-08045-I

This handbook confers no industrial property rights or any rights of any other kind, nor does it confer any patent licenses. Mitsubishi Electric Corporation cannot be held responsible for any problems involving industrial property rights which may occur as a result of using the contents noted in this handbook.

CONTENTS

SAFETY PRECAUTIONS	A - 1
CONDITIONS OF USE FOR THE PRODUCT	A - 7
REVISIONS	A - 8

CHAPTER 1 INTRODUCTION **1 - 1 to 1 - 2**

1.1 Advantages of Transition to Q Series	1 - 1
1.2 Precautions for Transition from Large-sized A/QnA Series to Q Series	1 - 2

CHAPTER 2 ANALOG INPUT MODULE REPLACEMENT **2 - 1 to 2 - 58**

2.1 List of Analog Input Module Alternative Models for Replacement	2 - 1
2.2 A616AD	2 - 3
2.2.1 Performance comparison	2 - 3
2.2.2 Function comparison	2 - 7
2.2.3 I/O signal comparison to programmable controller CPU	2 - 8
2.2.4 Buffer memory address comparison	2 - 9
2.3 A68AD (Upgrade to Q68ADV, Q68ADI)	2 - 11
2.3.1 Performance comparison	2 - 11
2.3.2 Function comparison	2 - 15
2.3.3 I/O signal comparison to programmable controller CPU	2 - 16
2.3.4 Buffer memory address comparison	2 - 17
2.4 A68AD (Upgrade to Q68AD-G)	2 - 19
2.4.1 Performance comparison	2 - 19
2.4.2 Function comparison	2 - 23
2.4.3 I/O signal comparison to programmable controller CPU	2 - 24
2.4.4 Buffer memory address comparison	2 - 25
2.5 A68AD-S2 (Upgrade to Q68ADV, Q68ADI)	2 - 27
2.5.1 Performance comparison	2 - 27
2.5.2 Function comparison	2 - 31
2.5.3 I/O signal comparison to programmable controller CPU	2 - 32
2.5.4 Buffer memory address comparison	2 - 33
2.6 A68AD-S2 (Upgrade to Q68AD-G)	2 - 35
2.6.1 Performance comparison	2 - 35
2.6.2 Function comparison	2 - 39
2.6.3 I/O signal comparison to programmable controller CPU	2 - 40
2.6.4 Buffer memory address comparison	2 - 41
2.7 A68ADN (Upgrade to Q68ADV, Q68ADI)	2 - 43
2.7.1 Performance comparison	2 - 43
2.7.2 Function comparison	2 - 47
2.7.3 I/O signal comparison to programmable controller CPU	2 - 48
2.7.4 Buffer memory address comparison	2 - 49
2.8 A68AD (Upgrade to Q68AD-G)	2 - 51
2.8.1 Performance comparison	2 - 51
2.8.2 Function comparison	2 - 55

2.8.3	I/O signal comparison to programmable controller CPU	2 - 56
2.8.4	Buffer memory address comparison	2 - 57

CHAPTER 3 ANALOG OUTPUT MODULE REPLACEMENT
3 - 1 to 3 - 66

3.1	List of Analog Output Module Alternative Models for Replacement	3 - 1
3.2	A616DAI	3 - 3
3.2.1	Performance comparison	3 - 3
3.2.2	Functional comparison	3 - 7
3.2.3	I/O signal comparison to programmable controller CPU	3 - 8
3.2.4	Buffer memory address comparison	3 - 9
3.3	A616DAV	3 - 11
3.3.1	Performance comparison	3 - 11
3.3.2	Functional comparison	3 - 15
3.3.3	I/O signal comparison to programmable controller CPU	3 - 16
3.3.4	Buffer memory address comparison	3 - 17
3.4	A62DA (Replacement to the Q62DAN)	3 - 19
3.4.1	Performance comparison	3 - 19
3.4.2	Functional comparison	3 - 23
3.4.3	I/O signal comparison to programmable controller CPU	3 - 24
3.4.4	Buffer memory address comparison	3 - 25
3.5	A62DA (Replacement to the Q64DAN)	3 - 27
3.5.1	Performance comparison	3 - 27
3.5.2	Functional comparison	3 - 31
3.5.3	I/O signal comparison to programmable controller CPU	3 - 32
3.5.4	Buffer memory address comparison	3 - 33
3.6	A62DA-S1 (Replacement to the Q62DAN)	3 - 35
3.6.1	Performance comparison	3 - 35
3.6.2	Functional comparison	3 - 39
3.6.3	I/O signal comparison to programmable controller CPU	3 - 40
3.6.4	Buffer memory address comparison	3 - 41
3.7	A62DA-S1 (Replacement to the Q64DAN)	3 - 43
3.7.1	Performance comparison	3 - 43
3.7.2	Functional comparison	3 - 47
3.7.3	I/O signal comparison to programmable controller CPU	3 - 48
3.7.4	Buffer memory address comparison	3 - 49
3.8	A68DAI(-S1)	3 - 51
3.8.1	Performance comparison	3 - 51
3.8.2	Functional comparison	3 - 55
3.8.3	I/O signal comparison to programmable controller CPU	3 - 56
3.8.4	Buffer memory address comparison	3 - 57
3.9	A68DAV	3 - 59
3.9.1	Performance comparison	3 - 59
3.9.2	Functional comparison	3 - 63
3.9.3	I/O signal comparison to programmable controller CPU	3 - 64
3.9.4	Buffer memory address comparison	3 - 65

CHAPTER 4 TEMPERATURE INPUT MODULE REPLACEMENT**4 - 1 to 4 - 70**

4.1	List of Temperature Input Module Alternative Models for Replacement	4 - 1
4.2	A616TD (Replacement to the Q64TD)	4 - 3
4.2.1	Performance comparison	4 - 3
4.2.2	Functional comparison	4 - 7
4.2.3	I/O signal comparison to programmable controller CPU	4 - 8
4.2.4	Buffer memory address comparison	4 - 9
4.3	A616TD (Replacement to the Q68TD-G-H02, Q68TD-G-H01)	4 - 13
4.3.1	Performance comparison	4 - 13
4.3.2	Functional comparison	4 - 18
4.3.3	I/O signal comparison to programmable controller CPU	4 - 19
4.3.4	Buffer memory address comparison	4 - 20
4.4	A68RD3N (Replacement to the Q64RD)	4 - 23
4.4.1	Performance comparison	4 - 23
4.4.2	Functional comparison	4 - 27
4.4.3	I/O signal comparison to programmable controller CPU	4 - 28
4.4.4	Buffer memory address comparison	4 - 29
4.5	A68RD3N (Replacement to the Q64RD-G)	4 - 33
4.5.1	Performance comparison	4 - 33
4.5.2	Functional comparison	4 - 37
4.5.3	I/O signal comparison to programmable controller CPU	4 - 38
4.5.4	Buffer memory address comparison	4 - 39
4.6	A68RD3N (Replacement to the Q68RD3-G)	4 - 43
4.6.1	Performance comparison	4 - 43
4.6.2	Functional comparison	4 - 47
4.6.3	I/O signal comparison to programmable controller CPU	4 - 48
4.6.4	Buffer memory address comparison	4 - 49
4.7	A68RD4N (Replacement to the Q64RD)	4 - 51
4.7.1	Performance comparison	4 - 51
4.7.2	Functional comparison	4 - 55
4.7.3	I/O signal comparison to programmable controller CPU	4 - 56
4.7.4	Buffer memory address comparison	4 - 57
4.8	A68RD4N (Replacement to the Q64RD-G)	4 - 61
4.8.1	Performance comparison	4 - 61
4.8.2	Functional comparison	4 - 65
4.8.3	I/O signal comparison to programmable controller CPU	4 - 66
4.8.4	Buffer memory address comparison	4 - 67

CHAPTER 5 MULTIPLEXER REPLACEMENT**5 - 1 to 5 - 11**

5.1	A60MX	5 - 1
5.1.1	Performance comparison	5 - 1
5.2	A60MXRN	5 - 5
5.2.1	Performance comparison	5 - 5
5.3	A60MXR	5 - 9

5.3.1	Performance comparison	5 - 9
-------	------------------------------	-------

CHAPTER 6	HIGH-SPEED COUNTER MODULE REPLACEMENT	6 - 1 to 6 - 13
------------------	--	------------------------

6.1	List of High-Speed Counter Module Alternative Models for Replacement	6 - 1
6.2	AD61	6 - 4
6.2.1	Performance comparison	6 - 4
6.2.2	Function comparison	6 - 6
6.2.3	I/O signal comparison to programmable controller CPU	6 - 7
6.2.4	Buffer memory address comparison	6 - 8
6.3	AD61S1	6 - 9
6.3.1	Performance comparison	6 - 9
6.3.2	Function comparison	6 - 11
6.3.3	I/O signal comparison to programmable controller CPU	6 - 12
6.3.4	Buffer memory address comparison	6 - 13

CHAPTER 7	POSITIONING MODULE REPLACEMENT	7 - 1 to 7 - 54
------------------	---------------------------------------	------------------------

7.1	List of Positioning Module Alternative Models for Replacement	7 - 1
7.2	AD70D	7 - 2
7.3	AD72	7 - 2
7.4	AD75P1-S3/P2-S3/P3-S3	7 - 3
7.4.1	Performance comparison	7 - 3
7.4.2	Function comparison	7 - 8
7.4.3	I/O signal comparison to programmable controller CPU	7 - 11
7.4.4	Buffer memory address comparison	7 - 12
7.4.5	Interface specifications comparison with external devices	7 - 20
7.5	AD75M1/M2/M3	7 - 21
7.5.1	Performance comparison	7 - 21
7.5.2	Function comparison	7 - 24
7.5.3	I/O signal comparison to programmable controller CPU	7 - 27
7.5.4	Buffer memory address comparison	7 - 28
7.5.5	Interface specifications comparison with external devices	7 - 40
7.6	AD70	7 - 43
7.6.1	Performance specifications comparison	7 - 43
7.6.2	Function comparison	7 - 45
7.6.3	I/O signals comparison to CPU module	7 - 49
7.6.4	Buffer memory address comparison	7 - 50
7.6.5	Interface specifications comparison with external devices	7 - 52
7.6.6	Precautions for the replacement of the AD70 by the QD73A1	7 - 53

CHAPTER 8	UPGRADE OF THE POSITION	8 - 1 to 8 - 2
------------------	--------------------------------	-----------------------

8.1	A61LS	8 - 1
8.2	A62LS-S5 and A63LS	8 - 2

CHAPTER 9	EXTERNAL DIMENSIONS	9 - 1 to 9 - 2
------------------	----------------------------	-----------------------

9.1 External Dimensions	9 - 1
-------------------------------	-------

APPENDICES**App - 1 to App - 5**

Appendix 1 Spare parts storage	App - 1
Appendix 2 Related Manuals	App - 2
Appendix 2.1 Replacement Handbooks	App - 2
Appendix 2.2 A/QnA series	App - 3
Appendix 2.3 Q series	App - 3
Appendix 2.4 Programming tool	App - 4

- For the products shown in handbooks for transition, catalogues, and transition examples, refer to the manuals for the relevant products and check the detailed specifications, precautions for use, and restrictions before replacement.

For the products manufactured by Mitsubishi Electric Engineering Co., Ltd., Mitsubishi Electric System & Service Co., Ltd., and other companies, refer to the catalogue for each product and check the detailed specifications, precautions for use, and restrictions before use.

The manuals and catalogues for our products, products manufactured by Mitsubishi Electric Engineering Co., Ltd., and Mitsubishi Electric System & Service Co., Ltd. are shown in Appendix of each handbook for transition.

- Products shown in this handbook are subject to change without notice.

1 INTRODUCTION

1.1 Advantages of Transition to Q Series

Advantage 1)Advanced performance of equipments

In addition to the processing performance improvement for Q series CPU, the processing speed for Q series intelligent function module is also increased, so that the equipment capability to improve is possible.

Advantage 2)Compact control panel and space saving

As the Q series needs only 1/4 mounting area of the A series, it is possible to create more compact control panel.

Advantage 3)Improved operating efficiency for programming and monitor

Q series intelligent function module prepares the following utility package (GX Configurator-o) sold separately.

(Example)

- GX Configurator-AD Analog input module setting/monitoring tool
- GX Configurator-DA Analog output module setting/monitoring tool
- GX Configurator-TI Temperature input module setting/monitoring tool
- GX Configurator-CT High speed counter module setting/monitoring tool
- GX Configurator-QP Positioning module setting/monitoring tool

Using the utility package is not a must. However, the utility package allows not only for the followings to do, but also reduces sequence programs.

- Initial setting is possible without a program
- The auto refresh setting allows to read/write buffer memory data of intelligent function module automatically from/to the CPU device memory.
- Checking of the setting status or operating status of intelligent function module is simplified.

1.2 Precautions for Transition from Large-sized A/QnA Series to Q Series

- (1) Be sure to confirm its functions, specifications and instructions by referring the manual of the corresponding Q series module prior to use.
- (2) Be sure to check the operation of whole system before the actual operation.

2 ANALOG INPUT MODULE REPLACEMENT

2.1 List of Analog Input Module Alternative Models for Replacement

Production discontinuation		Transition to Q series	
Product	Model	Model	Remarks (Restrictions)
Analog input module	A616AD	Q68ADV	1) External wiring : Cable size is changed. 2) Number of slots : Changed (2 modules are required.) 3) Program : Occupied I/O points, I/O signals and buffer memory address are changed. 4) Performance specifications change: 8CH/module, input signals (Either V or I input) 5) Function specifications: Not changed
		Q68ADI	
	A68AD	Q68ADV	1) External wiring : Cable size is changed. 2) Number of slots : Not changed 3) Program : Occupied I/O points, I/O signals and buffer memory address are changed. 4) Performance specifications change: Input signals (Either V or I input) and I/O characteristics 5) Function specifications: Not changed
		Q68ADI	
		Q68AD-G*1	1) External wiring : Cable size is changed. (Terminal block wiring → connector wiring) 2) Number of slots : Not changed 3) Program : Occupied I/O points, I/O signals and buffer memory address are changed. 4) Performance specifications change: Conversion speed ((the maximum of 2.5ms/channel) → sampling cycle (10ms/channel) + response speed (20ms)) and I/O characteristics 5) Function specifications: Changed (Non-insulation → insulation between channels)
A68AD-S2	Q68ADV	1) External wiring : Cable size is changed. 2) Number of slots : Not changed 3) Program : Occupied I/O points, I/O signals and buffer memory address are changed. 4) Performance specifications change: Input signals (Either V or I input) and I/O characteristics 5) Function specifications: Not changed	
	Q68ADI		
	Q68AD-G*1	1) External wiring : Cable size is changed. (Terminal block wiring → connector wiring) 2) Number of slots : Not changed 3) Program : Occupied I/O points, I/O signals and buffer memory address are changed. 4) Performance specifications change: Conversion speed ((the maximum of 2.5ms/channel) → sampling cycle (10ms/channel) + response speed (20ms)) and I/O characteristics 5) Function specifications: Changed (Non-insulation → insulation between channels)	

Production discontinuation		Transition to Q series	
Product	Model	Model	Remarks (Restrictions)
Analog input module	A68ADN	Q68ADV Q68ADI	1) External wiring : Cable size is changed. 2) Number of slots : Not changed 3) Program : Occupied I/O points, I/O signals and buffer memory address are changed. 4) Performance specifications change: Input signals (Either V or I input) and increase in current consumption 5) Function specifications: Not changed
		Q68AD-G*1	1) External wiring : Cable size is changed. (Terminal block wiring → connector wiring) 2) Number of slots : Not changed 3) Program : Occupied I/O points, I/O signals and buffer memory address are changed. 4) Performance specifications change: Conversion speed ((20ms/channel) → sampling cycle (10ms/channel) + response speed (20ms)) 5) Function specifications: Changed (Non-insulation → insulation between channels)

*1 The Q68AD-G cannot be mounted on the Q series large type base unit (Q3□BL, Q6□BL, Q55BL).

☒ Point

The existing wiring for the A/QnA series modules can be connected directly to the Q series modules using the upgrade tool (conversion adaptor) manufactured by Mitsubishi Electric Engineering Co., Ltd.

(1) One slot type (can be mounted on the Q series large type base unit)

Product	MELSEC-A/QnA series module	MELSEC-Q series module	Conversion adaptor
Analog input module	A68AD	Q68ADV	ERNT-AQT68AD
		Q68ADI	
	A68AD-S2	Q68ADV	
		Q68ADI	
	A68ADN	Q68ADV	ERNT-AQT68ADN
		Q68ADI	

(2) Two slot type
(cannot be mounted on the Q series large type base unit)

Product	MELSEC-A/QnA series module	MELSEC-Q series module	Conversion adaptor
Analog input module	A68AD	Q64AD-GH (×2 modules)*1	ERNT-AQT68AD-GH
	A68AD-S2		
	A68ADN		
	A616AD (in voltage input)	Q68ADV (×2 modules)	ERNT-AQT616AD
	A616AD (in current input)	Q68ADI (×2 modules)	

*1 Replacement for the existing A series modules (large size) in the mixed use of voltage and current.
For the single use of voltage or current, replacing with a conversion adaptor of one slot type is possible.

For MELSEC-A/QnA (large type) Series to Q Series transition related products manufactured by Mitsubishi Electric Engineering Co., Ltd. or Mitsubishi Electric System & Service Co., Ltd., contact your local sales office or representative.

2.2 A616AD

2.2.1 Performance comparison

Item		A616AD																																
Analog input	Voltage	-10 to 0 to +10VDC (Input resistance value: 1MΩ)																																
	Current	-20 to 0 to +20mADC (Input resistance value: 250Ω)																																
Digital output		16-bit signed binary (Data part: 12 bit) (-48 to 4047, -2048 to 2047) Setting is enabled for each channel.																																
I/O characteristics maximum resolution		<table border="1"> <thead> <tr> <th>Input</th> <th>Analog input range</th> <th>Maximum resolution</th> <th>Digital output value</th> </tr> </thead> <tbody> <tr> <td rowspan="5">Voltage (V)</td> <td>0 to +10</td> <td>2.5mV (1/4000)</td> <td rowspan="5">0 to 4000 -2000 to 2000</td> </tr> <tr> <td>0 to +5</td> <td>1.25mV (1/4000)</td> </tr> <tr> <td>+1 to +5</td> <td>1.0mV (1/4000)</td> </tr> <tr> <td>-10 to +10</td> <td>5.0mV (1/4000)</td> </tr> <tr> <td>-5 to +5</td> <td>2.5mV (1/4000)</td> </tr> <tr> <td rowspan="5">Current (mA)</td> <td>0 to +20</td> <td>10μA (1/2000)</td> <td>0 to 2000 -2000 to 0</td> </tr> <tr> <td>0 to +20</td> <td>5μA (1/4000)</td> <td>0 to 4000</td> </tr> <tr> <td>+4 to +20</td> <td>4μA (1/4000)</td> <td>-2000 to 2000</td> </tr> <tr> <td>-20 to +20</td> <td>20μA (1/2000)</td> <td>1000 to 3000 -1000 to 1000</td> </tr> <tr> <td>-20 to +20</td> <td>10μA (1/4000)</td> <td>0 to 4000 -2000 to 2000</td> </tr> </tbody> </table>	Input	Analog input range	Maximum resolution	Digital output value	Voltage (V)	0 to +10	2.5mV (1/4000)	0 to 4000 -2000 to 2000	0 to +5	1.25mV (1/4000)	+1 to +5	1.0mV (1/4000)	-10 to +10	5.0mV (1/4000)	-5 to +5	2.5mV (1/4000)	Current (mA)	0 to +20	10μA (1/2000)	0 to 2000 -2000 to 0	0 to +20	5μA (1/4000)	0 to 4000	+4 to +20	4μA (1/4000)	-2000 to 2000	-20 to +20	20μA (1/2000)	1000 to 3000 -1000 to 1000	-20 to +20	10μA (1/4000)	0 to 4000 -2000 to 2000
Input	Analog input range	Maximum resolution	Digital output value																															
Voltage (V)	0 to +10	2.5mV (1/4000)	0 to 4000 -2000 to 2000																															
	0 to +5	1.25mV (1/4000)																																
	+1 to +5	1.0mV (1/4000)																																
	-10 to +10	5.0mV (1/4000)																																
	-5 to +5	2.5mV (1/4000)																																
Current (mA)	0 to +20	10μA (1/2000)	0 to 2000 -2000 to 0																															
	0 to +20	5μA (1/4000)	0 to 4000																															
	+4 to +20	4μA (1/4000)	-2000 to 2000																															
	-20 to +20	20μA (1/2000)	1000 to 3000 -1000 to 1000																															
	-20 to +20	10μA (1/4000)	0 to 4000 -2000 to 2000																															
Overall accuracy		<p>When using A616AD only 0 to 10V, -10 to 10V } Range: ±0.3% -5V to 5V, -20 to 20mA } (Digital value ±12)</p> <p>0 to 5V, 1 to 5V } Range: ±0.6% 0 to 20mA, 4 to 20mA } (Digital value ±24)</p> <p>When using combination with any of A60MX, A60MXR, A60MXRN, the accuracy of each range of A616AD is ±0.3% (Digital output value ±12).</p>																																

○: Compatible, △: Partial change required, ×: Incompatible

	Q68ADV	Q68ADI	Compatibility	Precautions for replacement																																																						
	-10 to 10VDC (Input resistance value: 1MΩ)	-	△	The voltage/current cannot be mixed for one module.																																																						
	-	0 to 20mADC (Input resistance value: 250Ω)																																																								
	16-bit signed binary (Normal resolution mode: -4096 to 4095, High resolution mode: -12288 to 12287, -16384 to 16383)		△	A616AD can set the data format to [-2048 to 2047]. However, Q68ADV/I cannot set. When using the conversion data of Q68ADV/I in [-2048 to 2047], convert with sequence program.																																																						
	<table border="1"> <thead> <tr> <th rowspan="2">Analog input range</th> <th colspan="2">Normal resolution mode</th> <th colspan="2">High resolution mode</th> </tr> <tr> <th>Digital output value</th> <th>Maximum resolution</th> <th>Digital output value</th> <th>Maximum resolution</th> </tr> </thead> <tbody> <tr> <td rowspan="4">Voltage</td> <td>0 to 10V</td> <td rowspan="3">0 to 4000</td> <td>2.5mV</td> <td>0 to 16000</td> <td>0.625mV</td> </tr> <tr> <td>0 to 5V</td> <td>1.25mV</td> <td rowspan="2">0 to 12000</td> <td>0.416mV</td> </tr> <tr> <td>1 to 5V</td> <td>1.0mV</td> <td>0.333mV</td> </tr> <tr> <td>-10 to 10V</td> <td rowspan="2">-4000 to 4000</td> <td>2.5mV</td> <td>-16000 to 16000</td> <td>0.625mV</td> </tr> <tr> <td>User range settings</td> <td>0.375mV</td> <td>-12000 to 12000</td> <td>0.333mV</td> </tr> <tr> <td rowspan="3">Current</td> <td>0 to 20mA</td> <td rowspan="2">0 to 4000</td> <td>5μA</td> <td rowspan="2">0 to 12000</td> <td>1.66μA</td> </tr> <tr> <td>4 to 20mA</td> <td>4μA</td> <td>1.33μA</td> </tr> <tr> <td>User range settings</td> <td>-4000 to 4000</td> <td>1.37μA</td> <td>-12000 to 12000</td> <td>1.33μA</td> </tr> </tbody> </table>		Analog input range	Normal resolution mode		High resolution mode		Digital output value	Maximum resolution	Digital output value	Maximum resolution	Voltage	0 to 10V	0 to 4000	2.5mV	0 to 16000	0.625mV	0 to 5V	1.25mV	0 to 12000	0.416mV	1 to 5V	1.0mV	0.333mV	-10 to 10V	-4000 to 4000	2.5mV	-16000 to 16000	0.625mV	User range settings	0.375mV	-12000 to 12000	0.333mV	Current	0 to 20mA	0 to 4000	5μA	0 to 12000	1.66μA	4 to 20mA	4μA	1.33μA	User range settings	-4000 to 4000	1.37μA	-12000 to 12000	1.33μA	△	When using A616AD in [-5 to +5V] range, Q68ADV can obtain equivalent resolution or more than A616AD by setting in [-10 to 10V] range/high resolution mode or user range. When using A616AD in [-20 to +20mA] range, use Q68ADI in user range.									
Analog input range	Normal resolution mode			High resolution mode																																																						
	Digital output value	Maximum resolution	Digital output value	Maximum resolution																																																						
Voltage	0 to 10V	0 to 4000	2.5mV	0 to 16000	0.625mV																																																					
	0 to 5V		1.25mV	0 to 12000	0.416mV																																																					
	1 to 5V		1.0mV		0.333mV																																																					
	-10 to 10V	-4000 to 4000	2.5mV	-16000 to 16000	0.625mV																																																					
User range settings	0.375mV		-12000 to 12000	0.333mV																																																						
Current	0 to 20mA	0 to 4000	5μA	0 to 12000	1.66μA																																																					
	4 to 20mA		4μA		1.33μA																																																					
	User range settings	-4000 to 4000	1.37μA	-12000 to 12000	1.33μA																																																					
	<table border="1"> <thead> <tr> <th rowspan="3">Analog input range</th> <th colspan="3">Normal resolution mode</th> <th colspan="3">High resolution mode</th> </tr> <tr> <th colspan="2">Ambient temperature 0 to 55°C</th> <th rowspan="2">Ambient temperature 25±5°C</th> <th colspan="2">Ambient temperature 0 to 55°C</th> <th rowspan="2">Ambient temperature 25±5°C</th> </tr> <tr> <th>With temperature drift compensation</th> <th>Without temperature drift compensation</th> <th>With temperature drift compensation</th> <th>Without temperature drift compensation</th> </tr> </thead> <tbody> <tr> <td rowspan="4">Voltage</td> <td>0 to 10V</td> <td rowspan="4">±0.3% (±12 digits)</td> <td rowspan="4">±0.4% (±16 digits)</td> <td rowspan="4">±0.1% (±4 digits)</td> <td>±0.3% (±48 digits)</td> <td>±0.4% (±64 digits)</td> <td>±0.1% (±16 digits)</td> </tr> <tr> <td>-10 to 10V</td> <td rowspan="3">±0.3% (±36 digits)</td> <td rowspan="3">±0.4% (±48 digits)</td> <td rowspan="3">±0.1% (±12 digits)</td> </tr> <tr> <td>0 to 5V</td> </tr> <tr> <td>1 to 5V</td> </tr> <tr> <td>User range settings</td> <td></td> <td></td> <td></td> </tr> <tr> <td rowspan="3">Current</td> <td>0 to 20mA</td> <td></td> <td></td> <td></td> <td></td> <td></td> </tr> <tr> <td>4 to 20mA</td> <td></td> <td></td> <td></td> <td></td> <td></td> </tr> <tr> <td>User range settings</td> <td></td> <td></td> <td></td> <td></td> <td></td> </tr> </tbody> </table>		Analog input range	Normal resolution mode			High resolution mode			Ambient temperature 0 to 55°C		Ambient temperature 25±5°C	Ambient temperature 0 to 55°C		Ambient temperature 25±5°C	With temperature drift compensation	Without temperature drift compensation	With temperature drift compensation	Without temperature drift compensation	Voltage	0 to 10V	±0.3% (±12 digits)	±0.4% (±16 digits)	±0.1% (±4 digits)	±0.3% (±48 digits)	±0.4% (±64 digits)	±0.1% (±16 digits)	-10 to 10V	±0.3% (±36 digits)	±0.4% (±48 digits)	±0.1% (±12 digits)	0 to 5V	1 to 5V	User range settings				Current	0 to 20mA						4 to 20mA						User range settings						○	A616AD is the accuracy in respect to the full scale, and Q68ADV/I is the accuracy in respect to maximum digital output value.
Analog input range	Normal resolution mode			High resolution mode																																																						
	Ambient temperature 0 to 55°C			Ambient temperature 25±5°C	Ambient temperature 0 to 55°C		Ambient temperature 25±5°C																																																			
	With temperature drift compensation	Without temperature drift compensation	With temperature drift compensation		Without temperature drift compensation																																																					
Voltage	0 to 10V	±0.3% (±12 digits)	±0.4% (±16 digits)	±0.1% (±4 digits)	±0.3% (±48 digits)	±0.4% (±64 digits)	±0.1% (±16 digits)																																																			
	-10 to 10V				±0.3% (±36 digits)	±0.4% (±48 digits)	±0.1% (±12 digits)																																																			
	0 to 5V																																																									
	1 to 5V																																																									
User range settings																																																										
Current	0 to 20mA																																																									
	4 to 20mA																																																									
	User range settings																																																									

Item	A616AD	
Maximum conversion speed	When using only A616AD: 1 When using a combination with A60MX: 1 When using a combination with A60MXR: 1 (Sampling processing time), 7.0 (Direct access processing) When using a combination with A60MXRN: 1 (Sampling processing time), 7.0 (Direct access processing) [Unit: ms/channel]	
Absolute maximum input	Voltage: ±15V Current: ±30mA	
Analog input points	16 channels/module	
Maximum number of writes for E ² PROM	-	
Isolation method	Between the input terminal and programmable controller: photocoupler isolation Between channels: non-isolated (1MΩ resistor isolation)	
Dielectric withstand voltage	-	
Insulation resistance	-	
Occupied I/O points	32 points (I/O assignment: special 32 points)	
Connected terminal	38-point terminal block	
Applicable wire size	0.75 to 2mm ² (Applicable tightening torque: 39 to 59N•cm)	
Applicable solderless terminal	V1.25-3, V1.25-YS3A, V2-S3, V2-YS3A	
Internal current consumption (5VDC)	1A	
Weight	0.85kg	

○ : Compatible, △ : Partial change required, × : Incompatible

	Q68ADV	Q68ADI	Compatibility	Precautions for replacement
	80μs/channel (When there is temperature drift compensation, the time calculated by adding 160μs will be used regardless of the number of channels used.)		○	The conversion speed of Q68ADV/I to A616AD has become quick. And then, on Q68ADV/I, the noise that did not import on A616AD can be imported as analog signal. In this case, use the averaging processing function to remove the effect of noise.
	±15V	±30mA	○	
	8 channels/module		△	Consider replacement with multiple Q68ADV/I.
	Max. 100,000 times		○	
	Between the I/O terminal and programmable controller power supply: photocoupler isolation Between channels: non-isolated		○	
	Between the I/O terminal and programmable controller power supply: 500VAC, for 1 minute		○	
	Between the I/O terminal and programmable controller power supply: 500VDC, 20MΩ or more		○	
	16 points (I/O assignment: intelligent 16 points)		△	I/O occupied points has changed to 16 points.
	18-point terminal block		×	Wiring change is required.
	0.3 to 0.75mm ²		×	
	R1.25-3 (A solderless terminal with sleeve can not be used.)		×	
	0.64A	0.64A	○	
	0.19kg	0.19kg	○	

2.2.2 Function comparison

○ : With functions, - : Without functions

Item	Description	A616AD	Q68ADV/I	Precautions for replacement
A/D conversion enable/disable	Specifies whether to enable or disable the A/D conversion for each channel. By disabling the conversion for the channels that are not used, the sampling time can be shortened.	-	○	
Sampling processing	The A/D conversion for analog input values is performed successively for each channel, and the digital output value is output upon each conversion.	○	○	The sampling processing time changes depending on the number of channels used (number of channels set to A/D conversion enable) and whether, with or without the temperature drift compensation function. (a) Without temperature drift compensation function (processing time) = (number of channels used) × 80 (μs /1 channel) (b) With temperature drift compensation function (processing time)= (number of channels used) × 80 (μs /1 channel) +160μs
Direct access processing	Sequence program separately from normal sampling processing can specify channels to carry out the A/D conversion, and outputting the direct access request can perform direct A/D conversion of specified channels. When inputting channel specification with sampling processing and direct access processing simultaneously, the direct access request is prioritized.	○	-	Q68ADV/I does not have [Direct access processing] function.
Averaging processing	For each channel, A/D conversion values are averaged for the set number of times or set amount of time, and the average value is output as a digital value. The setting range is as shown below: Averaging processing by the number of times: 4 to 62500 Averaging processing by time: 2 to 5000ms	-	○	
Maximum and minimum values hold function	The maximum and minimum values of the digital output values are retained in the module.	-	○	
Temperature drift compensation function	Errors arising from changes in the ambient temperature of the module are automatically compensated to improve conversion accuracy. The temperature drift compensation function can be performed at (A/D conversion time for all channels) + 160μs.	-	○	
Resolution mode	The resolution settings of 1/4000, 1/12000 or 1/16000 can be selected according to the application. The resolution mode setting is applicable to all channels.	-	○	
Online module change	A module change is made without the system being stopped.	-	○	The CPUs corresponding to online module replacement are process CPU and redundant CPU modules.

2.2.3 I/O signal comparison to programmable controller CPU

Sequence program change is required as the I/O signals differ.

For details of the I/O signals or sequence program, refer to the Analog-Digital Converter Module User's Manual.

A616AD				Q68ADV/I					
Device No.	Signal name	Device No.	Signal name	Device No.	Signal name	Device No.	Signal name		
X0	Watchdog timer error	Y0	Not used	X0	Module READY	Y0	Not used		
X1	A/D conversion READY	Y1		X1	Temperature drift compensation flag	Y1			
X2	Error flag	Y2		X2	Not used	Y2			
X3		Y3		X3		Y3			
X4		Y4		X4		Y4			
X5		Y5		X5		Y5			
X6		Y6		X6		Y6			
X7		Y7		X7		Y7			
X8		Y8		X8		High resolution mode status flag		Y8	
X9		Y9		X9	Operating condition setting completed flag	Y9		Operating condition setting request	
XA		YA		XA	Offset/gain setting mode flag	YA		User range write request	
XB		YB		XB	Channel change completed flag	YB		Channel change request	
XC		YC		XC	Not used	YC		Not used	
XD	Not used	YD		RFRP, RTOP instruction for interlock signal when A616AD is used in remote I/O station	XD	Maximum value/minimum value reset completed flag		YD	Maximum value/minimum value reset request
XE		YE		XE	A/D conversion completed flag	YE		Not used	
XF		YF		XF	Error flag	YF		Error clear request	
X10		Y10		Not used					
X11		Y11							
X12		Y12							
X13		Y13							
X14		Y14							
X15		Y15							
X16		Y16							
X17		Y17							
X18		Y18	Direct access request signal						
X19		Y19	Not used						
X1A		Y1A							
X1B		Y1B							
X1C		Y1C							
X1D	RFRP, RTOP instruction for interlock signal when A616AD is used in remote I/O station	Y1D							
X1E		Y1E							
X1F		Y1F							

2.2.4 Buffer memory address comparison

Sequence program change is required as the assignment of buffer memory differs.

For details of the buffer memory or sequence program, refer to the Analog-Digital Converter Module User's Manual.

A616AD			Q68ADV/I			
Address (Dec.)	Name	Read/write	Address (Dec.)	Name	Read/write	
0	For direct access	INPUT designation	0	A/D conversion enable/disable		
1		MX. CH. designation	1	CH1 Time/count averaging setting		
2		Digital output value	R	2		CH2 Time/count averaging setting
3	Sampling period designation	R/W	3	CH3 Time/count averaging setting	R/W	
4	Data format selection		4	CH4 Time/count averaging setting		
5	Error code storage		5	CH5 Time/count averaging setting		
6	Faulty multiplexer module CNT. No. storage		6	CH6 Time/count averaging setting		
7	System area (Not used)	-	7	CH7 Time/count averaging setting		
8			8	CH8 Time/count averaging setting		
9			9	Averaging processing specification		
10			10	A/D conversion completed flag		
11			11	CH1 Digital output value		
12			12	CH2 Digital output value		
13			13	CH3 Digital output value		
14			14	CH4 Digital output value		
15	Conversion enable/disable designation	A616AD	15	CH5 Digital output value	R	
16		INPUT 0 A60MX, A60MXR	16	CH6 Digital output value		
17		INPUT 1 A60MX, A60MXR	17	CH7 Digital output value		
18		INPUT 2 A60MX, A60MXR	18	CH8 Digital output value		
19		INPUT 3 A60MX, A60MXR	19	Error code		
20		INPUT 4 A60MX, A60MXR	20	Setting range (CH1 to CH4)		
21		INPUT 5 A60MX, A60MXR	21	Setting range (CH5 to CH8)		
22		INPUT 6 A60MX, A60MXR	22	Offset/gain setting mode Offset specification		R/W
23	INPUT 7 A60MX, A60MXR	23	Offset/gain setting mode Gain specification			
24	Set data setting request	-	24	System area (Not used)		
25	System area (Not used)		25			
26			26			
27			27			
28			28			
29			29			
30			30	CH1 Maximum value		R
31			31	CH1 Minimum value		
32		32	CH2 Maximum value			
33	33	CH2 Minimum value				
34	34	CH3 Maximum value				
35	35	CH3 Minimum value				
36	36	CH4 Maximum value				
37	37	CH4 Minimum value				
38	38	CH5 Maximum value				
39	39	CH5 Minimum value				
40	40	CH6 Maximum value				
41	41	CH6 Minimum value				
42	42	CH7 Maximum value				
43	43	CH7 Minimum value				
44	44	CH8 Maximum value				
45	45	CH8 Minimum value				

A616AD			Q68ADV/I		
Address (Dec.)	Name	Read/write	Address (Dec.)	Name	Read/write
46	System area (Not used)	-	46	System area (Not used)	-
47					
48	INPUT channel digital output value	R	48	System area (Not used)	-
to					
63					
64					
to					
157			157	Mode switching setting	R/W
158					
159					
160					
to					
201	System area (Not used)	-	201	System area (Not used)	-
202					
203					
204					
205					
206					
207					
208					
209					
210					
211					
212					
213					
214					
215					
216					
217					
218					
219					
220					
221					
222					
223					
224					
225					
226					
227					
228					
229					
230					
231					
232					
233					
234					
to					
255					
256	MX. CH. channel digital output value	R	256	CH1 Industrial shipment settings offset value	R/W
to					
383					
			202	CH1 Industrial shipment settings gain value	
			203	CH2 Industrial shipment settings offset value	
			204	CH2 Industrial shipment settings gain value	
			205	CH3 Industrial shipment settings offset value	
			206	CH3 Industrial shipment settings gain value	
			207	CH4 Industrial shipment settings offset value	
			208	CH4 Industrial shipment settings gain value	
			209	CH5 Industrial shipment settings offset value	
			210	CH5 Industrial shipment settings gain value	
			211	CH6 Industrial shipment settings offset value	
			212	CH6 Industrial shipment settings gain value	
			213	CH7 Industrial shipment settings offset value	
			214	CH7 Industrial shipment settings gain value	
			215	CH8 Industrial shipment settings offset value	
			216	CH8 Industrial shipment settings gain value	
			217	CH1 User range settings offset value	
			218	CH1 User range settings gain value	
			219	CH2 User range settings offset value	
			220	CH2 User range settings gain value	
			221	CH3 User range settings offset value	
			222	CH3 User range settings gain value	
			223	CH4 User range settings offset value	
			224	CH4 User range settings gain value	
			225	CH5 User range settings offset value	
			226	CH5 User range settings gain value	
			227	CH6 User range settings offset value	
			228	CH6 User range settings gain value	
			229	CH7 User range settings offset value	
			230	CH7 User range settings gain value	
			231	CH8 User range settings offset value	
			232	CH8 User range settings gain value	
			233		

2.3 A68AD (Upgrade to Q68ADV, Q68ADI)

2.3.1 Performance comparison

Item		A68AD												
Analog input	Voltage	-10 to 0 to +10VDC (Input resistance value: Hardware version K or later: 1MΩ, Hardware version J or earlier: 30kΩ)												
	Current	+4 to +20mADC (Input resistance value: 250Ω) *Usable current input: -20 to 0 to +20mA												
Digital output		16-bit signed binary (-2048 to +2047)												
I/O characteristics		<table border="1"> <thead> <tr> <th>Analog input</th> <th>Digital output</th> </tr> </thead> <tbody> <tr> <td>+10V</td> <td>+2000</td> </tr> <tr> <td>+5V or +20mA</td> <td>+1000</td> </tr> <tr> <td>0V or +4mA</td> <td>±0</td> </tr> <tr> <td>-5V or -12mA</td> <td>-1000</td> </tr> <tr> <td>-10V</td> <td>-2000</td> </tr> </tbody> </table>	Analog input	Digital output	+10V	+2000	+5V or +20mA	+1000	0V or +4mA	±0	-5V or -12mA	-1000	-10V	-2000
Analog input	Digital output													
+10V	+2000													
+5V or +20mA	+1000													
0V or +4mA	±0													
-5V or -12mA	-1000													
-10V	-2000													
Maximum resolution		Voltage: 5mV (1/2000) Current: 20μA (1/1000)												
Overall accuracy (Accuracy in respect to maximum digital output value)		±1% (±20)												
Maximum conversion speed		Max. 2.5ms/channel												
Absolute maximum input		Voltage: ±15V current: ±30mA												

○ : Compatible, △ : Partial change required, × : Incompatible

	Q68ADV	Q68ADI	Compatibility	Precautions for replacement																																																										
	-10 to 10VDC (Input resistance value: 1MΩ)	-	△	The voltage/current cannot be mixed for one module.																																																										
	-	0 to 20mADC (Input resistance value: 250Ω)																																																												
	16-bit signed binary (Normal resolution mode: -4096 to 4095, High resolution mode: -12288 to 12287, -16384 to 16383)		○																																																											
	<table border="1"> <thead> <tr> <th rowspan="2">Analog input range</th> <th colspan="2">Normal resolution mode</th> <th colspan="2">High resolution mode</th> </tr> <tr> <th>Digital output value</th> <th>Maximum resolution</th> <th>Digital output value</th> <th>Maximum resolution</th> </tr> </thead> <tbody> <tr> <td rowspan="4">Voltage</td> <td>0 to 10V</td> <td rowspan="3">0 to 4000</td> <td rowspan="3">0 to 12000</td> <td>2.5mV</td> </tr> <tr> <td>0 to 5V</td> <td>0.625mV</td> </tr> <tr> <td>1 to 5V</td> <td>0.416mV</td> </tr> <tr> <td>-10 to 10V</td> <td>1.0mV</td> <td>0.333mV</td> </tr> <tr> <td>User range settings</td> <td>-4000 to 4000</td> <td>2.5mV</td> <td>-16000 to 16000</td> <td>0.625mV</td> </tr> <tr> <td rowspan="3">Current</td> <td>0 to 20mA</td> <td rowspan="2">0 to 4000</td> <td rowspan="2">0 to 12000</td> <td>0.375mV</td> </tr> <tr> <td>4 to 20mA</td> <td>1.66μA</td> </tr> <tr> <td>User range settings</td> <td>-4000 to 4000</td> <td>1.37μA</td> <td>-12000 to 12000</td> <td>1.33μA</td> </tr> </tbody> </table>		Analog input range	Normal resolution mode		High resolution mode		Digital output value	Maximum resolution	Digital output value	Maximum resolution	Voltage	0 to 10V	0 to 4000	0 to 12000	2.5mV	0 to 5V	0.625mV	1 to 5V	0.416mV	-10 to 10V	1.0mV	0.333mV	User range settings	-4000 to 4000	2.5mV	-16000 to 16000	0.625mV	Current	0 to 20mA	0 to 4000	0 to 12000	0.375mV	4 to 20mA	1.66μA	User range settings	-4000 to 4000	1.37μA	-12000 to 12000	1.33μA	△	As concept of gain value is changed, refer to [Analog-Digital Converter Module User's Manual] and then, confirm the I/O characteristics.																				
Analog input range	Normal resolution mode			High resolution mode																																																										
	Digital output value	Maximum resolution	Digital output value	Maximum resolution																																																										
Voltage	0 to 10V	0 to 4000	0 to 12000	2.5mV																																																										
	0 to 5V			0.625mV																																																										
	1 to 5V			0.416mV																																																										
	-10 to 10V	1.0mV	0.333mV																																																											
User range settings	-4000 to 4000	2.5mV	-16000 to 16000	0.625mV																																																										
Current	0 to 20mA	0 to 4000	0 to 12000	0.375mV																																																										
	4 to 20mA			1.66μA																																																										
	User range settings	-4000 to 4000	1.37μA	-12000 to 12000	1.33μA																																																									
	<table border="1"> <thead> <tr> <th rowspan="3">Analog input range</th> <th colspan="3">Normal resolution mode</th> <th colspan="3">High resolution mode</th> </tr> <tr> <th colspan="2">Ambient temperature 0 to 55°C</th> <th rowspan="2">Ambient temperature 25±5°C</th> <th colspan="2">Ambient temperature 0 to 55°C</th> <th rowspan="2">Ambient temperature 25±5°C</th> </tr> <tr> <th>With temperature drift compensation</th> <th>Without temperature drift compensation</th> <th>With temperature drift compensation</th> <th>Without temperature drift compensation</th> </tr> </thead> <tbody> <tr> <td rowspan="4">Voltage</td> <td>0 to 10V</td> <td rowspan="4">±0.3% (±12 digits)</td> <td rowspan="4">±0.4% (±16 digits)</td> <td rowspan="4">±0.1% (±4 digits)</td> <td>±0.3% (±48 digits)</td> <td>±0.4% (±64 digits)</td> </tr> <tr> <td>-10 to 10V</td> <td>±0.3% (±36 digits)</td> <td>±0.4% (±48 digits)</td> </tr> <tr> <td>0 to 5V</td> <td></td> <td></td> </tr> <tr> <td>1 to 5V</td> <td></td> <td></td> </tr> <tr> <td rowspan="3">Current</td> <td>users range settings</td> <td></td> <td></td> <td></td> <td></td> <td></td> </tr> <tr> <td>0 to 20mA</td> <td></td> <td></td> <td></td> <td></td> <td></td> </tr> <tr> <td>4 to 20mA</td> <td></td> <td></td> <td></td> <td></td> <td></td> </tr> <tr> <td>users range settings</td> <td></td> <td></td> <td></td> <td></td> <td></td> </tr> </tbody> </table>		Analog input range	Normal resolution mode			High resolution mode			Ambient temperature 0 to 55°C		Ambient temperature 25±5°C	Ambient temperature 0 to 55°C		Ambient temperature 25±5°C	With temperature drift compensation	Without temperature drift compensation	With temperature drift compensation	Without temperature drift compensation	Voltage	0 to 10V	±0.3% (±12 digits)	±0.4% (±16 digits)	±0.1% (±4 digits)	±0.3% (±48 digits)	±0.4% (±64 digits)	-10 to 10V	±0.3% (±36 digits)	±0.4% (±48 digits)	0 to 5V			1 to 5V			Current	users range settings						0 to 20mA						4 to 20mA						users range settings						○	
Analog input range	Normal resolution mode			High resolution mode																																																										
	Ambient temperature 0 to 55°C			Ambient temperature 25±5°C	Ambient temperature 0 to 55°C		Ambient temperature 25±5°C																																																							
	With temperature drift compensation	Without temperature drift compensation	With temperature drift compensation		Without temperature drift compensation																																																									
Voltage	0 to 10V	±0.3% (±12 digits)	±0.4% (±16 digits)	±0.1% (±4 digits)	±0.3% (±48 digits)	±0.4% (±64 digits)																																																								
	-10 to 10V				±0.3% (±36 digits)	±0.4% (±48 digits)																																																								
	0 to 5V																																																													
	1 to 5V																																																													
Current	users range settings																																																													
	0 to 20mA																																																													
	4 to 20mA																																																													
users range settings																																																														
	80μs/channel (When there is temperature drift compensation, the time calculated by adding 160 μs will be used regardless of the number of channels used.)		○	The conversion speed of Q68ADV/I to A68AD has become quick. And then, on A68AD, the noise that did not import on Q68ADV/I can be imported as analog signal. In this case, use the averaging processing function to remove the effect of noise.																																																										
	±15V	±30mA	○																																																											

Item	A68AD
Analog input points	8 channels/module
Maximum number of writes for E ² PROM	-
Isolation method	Between the input terminal and programmable controller power supply: photocoupler isolation Between channels: non-isolated
Dielectric withstand voltage	-
Insulation resistance	-
Occupied I/O points	32 points (I/O assignment: special 32 points)
Connected terminal	38-point terminal block
Applicable wire size	0.75 to 2mm ² (Applicable tightening torque: 39 to 59N·cm)
Applicable solderless terminal	V1.25-3, V1.25-YS3A, V2-S3, V2-YS3A
Internal current consumption (5VDC)	Hardware version K or later: 0.39A Hardware version J or earlier: 0.9A
Weight	Hardware version K or later: 0.3kg Hardware version J or earlier: 0.6kg

○ : Compatible, △ : Partial change required, × : Incompatible

	Q68ADV	Q68ADI	Compatibility	Precautions for replacement
	8 channels/module		○	
	Max. 100,000 times		○	
	Between the I/O terminal and programmable controller power supply: photocoupler isolation Between channels: non-isolated		○	
	Between the I/O terminal and programmable controller power supply: 500VAC, for 1 minute		○	
	Between the I/O terminal and programmable controller power supply: 500VDC, 20MΩ or more		○	
	16 points (I/O assignment: intelligent 16 points)		△	I/O occupied points has changed to 16 points.
	18-point terminal block		×	Wiring change is required.
	0.3 to 0.75mm ²		×	
	R1.25-3 (A solderless terminal with sleeve can not be used.)		×	
	0.64A	0.64A	△	The recalculation of internal current consumption [5VDC] is required.
	0.19kg	0.19kg	○	

2.3.2 Function comparison

○ : With functions, - : Without functions

Item	Description	A68AD	Q68ADV/I	Precautions for replacement
A/D conversion enable/disable	Specifies whether to enable or disable the A/D conversion for each channel. By disabling the conversion for the channels that are not used, the sampling time can be shortened.	○	○	
Sampling processing	The A/D conversion for analog input values is performed successively for each channel, and the digital output value is output upon each conversion.	○	○	The sampling processing time changes depending on the number of channels used (number of channels set to A/D conversion enable) and whether, with or without the temperature drift compensation function. (a) Without temperature drift compensation function (processing time) = (number of channels used) × 80 (μs /1 channel) (b) With temperature drift compensation function (processing time)= (number of channels used) × 80 (μs /1 channel) + 160μs
Averaging processing	For each channel, A/D conversion values are averaged for the set number of times or set amount of time, and the average value is output as a digital value.	○	○	The setting range of average time and count differ. Refer to [Analog-Digital Converter Module User's Manual] and then, confirm the specifications.
Maximum and minimum values hold function	The maximum and minimum values of the digital output values are retained in the module.	-	○	
Temperature drift compensation function	Errors arising from changes in the ambient temperature of the module are automatically compensated for to improve conversion accuracy. The temperature drift compensation function can be performed at (A/D conversion time for all channels) + 160μs.	-	○	
Resolution mode	The resolution settings of 1/4000, 1/12000 or 1/16000 can be selected according to the application. The resolution mode setting is applicable to all channels.	-	○	
Online module change	A module change is made without the system being stopped.	-	○	Replaceable modules during online are a process CPU and a redundant CPU.

2.3.3 I/O signal comparison to programmable controller CPU

Sequence program change is required as the I/O signals differ.

For details of the I/O signals or sequence program, refer to the Analog-Digital Converter Module User's Manual.

A68AD				Q68ADV/I			
Device No.	Signal name	Device No.	Signal name	Device No.	Signal name	Device No.	Signal name
X0	Watchdog timer error	Y0	Not used	X0	Module READY	Y0	Not used
X1	A/D conversion READY	Y1		X1	Temperature drift compensation flag	Y1	
X2	Not used	Y2		X2	Not used	Y2	
X3		Y3		X3		Y3	
X4		Y4		X4		Y4	
X5		Y5		X5		Y5	
X6		Y6		X6		Y6	
X7		Y7		X7		Y7	
X8		Y8		X8		High resolution mode status flag	Y8
X9		Y9		X9	Operating condition setting completed flag	Y9	Operating condition setting request
XA		YA		XA	Offset/gain setting mode flag	YA	User range write request
XB		YB		XB	Channel change completed flag	YB	Channel change request
XC		YC		XC	Not used	YC	Not used
XD		YD		XD	Maximum value/minimum value reset completed flag	YD	Maximum value/minimum value reset request
XE		YE		XE	A/D conversion completed flag	YE	Not used
XF	YF	XF		Error flag	YF	Error clear request	
X10	Y10						
X11	Y11						
X12	Y12						
X13	Y13						
X14	Y14						
X15	Y15						
X16	Y16						
X17	Y17						
X18	Y18						
X19	Y19						
X1A	Y1A						
X1B	Y1B						
X1C	Y1C						
X1D	Y1D						
X1E	Y1E						
X1F	Y1F						

2.3.4 Buffer memory address comparison

Sequence program change is required as the assignment of buffer memory differs.

For details of the buffer memory or sequence program, refer to the Analog-Digital Converter Module User's Manual.

A68AD			Q68ADV/I		
Address (Dec.)	Name	Read/write	Address (Dec.)	Name	Read/write
0	Number of channels	R/W	0	A/D conversion enable/disable	R/W
1	Averaging processing specification		1	CH1 Time/count averaging setting	
2	CH1 Averaging time, count		2	CH2 Time/count averaging setting	
3	CH2 Averaging time, count		3	CH3 Time/count averaging setting	
4	CH3 Averaging time, count		4	CH4 Time/count averaging setting	
5	CH4 Averaging time, count		5	CH5 Time/count averaging setting	
6	CH5 Averaging time, count		6	CH6 Time/count averaging setting	
7	CH6 Averaging time, count		7	CH7 Time/count averaging setting	
8	CH7 Averaging time, count		8	CH8 Time/count averaging setting	
9	CH8 Averaging time, count	R	9	Averaging processing specification	R
10	CH1 Digital output value		10	A/D conversion completed flag	
11	CH2 Digital output value		11	CH1 Digital output value	
12	CH3 Digital output value		12	CH2 Digital output value	
13	CH4 Digital output value		13	CH3 Digital output value	
14	CH5 Digital output value		14	CH4 Digital output value	
15	CH6 Digital output value		15	CH5 Digital output value	
16	CH7 Digital output value		16	CH6 Digital output value	
17	CH8 Digital output value		17	CH7 Digital output value	
18	System area (Not used)	-	18	CH8 Digital output value	R/W
19			19	Error code	
20			20	Setting range (CH1 to CH4)	
21			21	Setting range (CH5 to CH8)	
22			22	Offset/gain setting mode Offset specification	
23			23	Offset/gain setting mode Gain specification	
24			24	System area (Not used)	
25			25		
26			26		
27			27		
28	28				
29	29				
30	-	-	30	CH1 Maximum value	R
31			31	CH1 Minimum value	
32			32	CH2 Maximum value	
33			33	CH2 Minimum value	
34			34	CH3 Maximum value	
			35	CH3 Minimum value	
			36	CH4 Maximum value	
			37	CH4 Minimum value	
	38	CH5 Maximum value			
	39	CH5 Minimum value			
	40	CH6 Maximum value			
	41	CH6 Minimum value			
	42	CH7 Maximum value			
	43	CH7 Minimum value			
	44	CH8 Maximum value			
	45	CH8 Minimum value			
34	Write data error code	R/W	34	CH3 Maximum value	

Q68ADV/I		
Address (Dec.)	Name	Read/write
46	System area (Not used)	-
to 157		
158	Mode switching setting	R/W
159		
160	System area (Not used)	-
to 201		
201		
202	CH1 Industrial shipment settings offset value	R/W
203	CH1 Industrial shipment settings gain value	
204	CH2 Industrial shipment settings offset value	
205	CH2 Industrial shipment settings gain value	
206	CH3 Industrial shipment settings offset value	
207	CH3 Industrial shipment settings gain value	
208	CH4 Industrial shipment settings offset value	
209	CH4 Industrial shipment settings gain value	
210	CH5 Industrial shipment settings offset value	
211	CH5 Industrial shipment settings gain value	
212	CH6 Industrial shipment settings offset value	
213	CH6 Industrial shipment settings gain value	
214	CH7 Industrial shipment settings offset value	
215	CH7 Industrial shipment settings gain value	
216	CH8 Industrial shipment settings offset value	
217	CH8 Industrial shipment settings gain value	
218	CH1 User range settings offset value	
219	CH1 User range settings gain value	
220	CH2 User range settings offset value	
221	CH2 User range settings gain value	
222	CH3 User range settings offset value	
223	CH3 User range settings gain value	
224	CH4 User range settings offset value	
225	CH4 User range settings gain value	
226	CH5 User range settings offset value	
227	CH5 User range settings gain value	
228	CH6 User range settings offset value	
229	CH6 User range settings gain value	
230	CH7 User range settings offset value	
231	CH7 User range settings gain value	
232	CH8 User range settings offset value	
233	CH8 User range settings gain value	

2.4 A68AD (Upgrade to Q68AD-G)

2.4.1 Performance comparison

Item		A68AD												
Analog input	Voltage	-10 to 0 to +10VDC (Input resistance value: Hardware version K or later: 1MΩ, Hardware version J or earlier: 30kΩ)												
	Current	+4 to +20mADC (Input resistance value: 250Ω) *Usable current input: -20 to 0 to +20mA												
Digital output		16-bit signed binary (-2048 to +2047)												
I/O characteristics		<table border="1"> <thead> <tr> <th>Analog input</th> <th>Digital output</th> </tr> </thead> <tbody> <tr> <td>+10V</td> <td>+2000</td> </tr> <tr> <td>+5V or +20mA</td> <td>+1000</td> </tr> <tr> <td>0V or +4mA</td> <td>±0</td> </tr> <tr> <td>-5V or -12mA</td> <td>-1000</td> </tr> <tr> <td>-10V</td> <td>-2000</td> </tr> </tbody> </table>	Analog input	Digital output	+10V	+2000	+5V or +20mA	+1000	0V or +4mA	±0	-5V or -12mA	-1000	-10V	-2000
Analog input	Digital output													
+10V	+2000													
+5V or +20mA	+1000													
0V or +4mA	±0													
-5V or -12mA	-1000													
-10V	-2000													
Maximum resolution		Voltage: 5mV (1/2000) Current: 20μA (1/1000)												
Overall accuracy (Accuracy in respect to maximum digital output value)		±1% (±20)												
Maximum conversion speed		Max. 2.5ms/channel												
Response time		-												
Absolute maximum input		Voltage: ±15V current: ±30mA												

○ : Compatible, △ : Partial change required, × : Incompatible

Q68AD-G		Compatibility	Precautions for replacement																																																							
-10 to 10VDC (Input resistance value: 1MΩ or more)		○																																																								
0 to 20mADC (Input resistance value: 250Ω)																																																										
16-bit signed binary (Normal resolution mode: -4096 to 4095, High resolution mode: -12288 to 12287, -16384 to 16383)		○																																																								
Input	<table border="1"> <thead> <tr> <th rowspan="2">Analog input range</th> <th colspan="2">Normal resolution mode</th> <th colspan="2">High resolution mode</th> </tr> <tr> <th>Digital output value</th> <th>Maximum resolution</th> <th>Digital output value</th> <th>Maximum resolution</th> </tr> </thead> <tbody> <tr> <td rowspan="6">Voltage</td> <td>0 to 10V</td> <td rowspan="3">0 to 4000</td> <td>2.5mV</td> <td rowspan="2">0 to 16000</td> <td>0.625mV</td> </tr> <tr> <td>0 to 5V</td> <td>1.25mV</td> <td rowspan="2">0 to 12000</td> <td>0.416mV</td> </tr> <tr> <td>1 to 5V</td> <td>1.0mV</td> <td>0.333mV</td> </tr> <tr> <td>1 to 5V (Expanded mode)</td> <td>-1000 to 4500</td> <td>1.0mV</td> <td>-3000 to 13500</td> <td>0.333mV</td> </tr> <tr> <td>-10 to 10V</td> <td rowspan="2">-4000 to 4000</td> <td>2.5mV</td> <td>-16000 to 16000</td> <td>0.625mV</td> </tr> <tr> <td>Users range setting</td> <td>0.375mV</td> <td>-12000 to 12000</td> <td>0.333mV</td> </tr> <tr> <td rowspan="4">Current</td> <td>0 to 20mA</td> <td rowspan="2">0 to 4000</td> <td>5μA</td> <td rowspan="2">0 to 12000</td> <td>1.66μA</td> </tr> <tr> <td>4 to 20mA</td> <td>4μA</td> <td>1.33μA</td> </tr> <tr> <td>4 to 20mA (Expanded mode)</td> <td>-1000 to 4500</td> <td>4μA</td> <td>-3000 to 13500</td> <td>1.33μA</td> </tr> <tr> <td>Users range setting</td> <td>-4000 to 4000</td> <td>1.37μA</td> <td>-12000 to 12000</td> <td>1.33μA</td> </tr> </tbody> </table>	Analog input range	Normal resolution mode		High resolution mode		Digital output value	Maximum resolution	Digital output value	Maximum resolution	Voltage	0 to 10V	0 to 4000	2.5mV	0 to 16000	0.625mV	0 to 5V	1.25mV	0 to 12000	0.416mV	1 to 5V	1.0mV	0.333mV	1 to 5V (Expanded mode)	-1000 to 4500	1.0mV	-3000 to 13500	0.333mV	-10 to 10V	-4000 to 4000	2.5mV	-16000 to 16000	0.625mV	Users range setting	0.375mV	-12000 to 12000	0.333mV	Current	0 to 20mA	0 to 4000	5μA	0 to 12000	1.66μA	4 to 20mA	4μA	1.33μA	4 to 20mA (Expanded mode)	-1000 to 4500	4μA	-3000 to 13500	1.33μA	Users range setting	-4000 to 4000	1.37μA	-12000 to 12000	1.33μA	△	As concept of gain value is changed, refer to Q68AD-G [User's Manual] and then, confirm the I/O characteristics.
Analog input range	Normal resolution mode		High resolution mode																																																							
	Digital output value	Maximum resolution	Digital output value	Maximum resolution																																																						
Voltage	0 to 10V	0 to 4000	2.5mV	0 to 16000	0.625mV																																																					
	0 to 5V		1.25mV		0 to 12000	0.416mV																																																				
	1 to 5V		1.0mV	0.333mV																																																						
	1 to 5V (Expanded mode)	-1000 to 4500	1.0mV	-3000 to 13500	0.333mV																																																					
	-10 to 10V	-4000 to 4000	2.5mV	-16000 to 16000	0.625mV																																																					
	Users range setting		0.375mV	-12000 to 12000	0.333mV																																																					
Current	0 to 20mA	0 to 4000	5μA	0 to 12000	1.66μA																																																					
	4 to 20mA		4μA		1.33μA																																																					
	4 to 20mA (Expanded mode)	-1000 to 4500	4μA	-3000 to 13500	1.33μA																																																					
	Users range setting	-4000 to 4000	1.37μA	-12000 to 12000	1.33μA																																																					
±0.1% Normal resolution mode: ±4digit High resolution mode (0 to 10V, -10 to 10V): ±16digit High resolution mode (Other than the above ranges): ±12digit Temperature coefficient: ±71.4ppm/°C (0.00714%/°C)		○																																																								
10ms/channel (Sampling cycle)		△	The conversion speed of Q68AD-G to A68AD has become slow. If fast conversion speed is required for control, the Q64AD is recommended.																																																							
20ms																																																										
Voltage: ±15V current: ±30mA		○																																																								

Item	A68AD	
Analog input points	8 channels/module	
Maximum number of writes for E ² PROM	-	
Isolation method	Between the input terminal and programmable controller power supply: photocoupler isolation Between channels: non-isolated	
Dielectric withstand voltage	-	
Insulation resistance	-	
Occupied I/O points	32 points (I/O assignment: special 32 points)	
Connected terminal	38-point terminal block	
Applicable wire size	0.75 to 2mm ² (Applicable tightening torque: 39 to 59N·cm)	
Applicable solderless terminal	V1.25-3, V1.25-YS3A, V2-S3, V2-YS3A	
Internal current consumption (5VDC)	Hardware version K or later: 0.39A Hardware version J or earlier: 0.9A	
Weight	Hardware version K or later: 0.3kg Hardware version J or earlier: 0.6kg	

○ : Compatible, △ : Partial change required, × : Incompatible

	Q68AD-G	Compatibility	Precautions for replacement
	8 channels/module	○	
	Up to 50,000 times	○	
	Between the I/O terminal and programmable controller power supply: transformer isolation Between channels: transformer isolation	○	
	Between the I/O terminal and programmable controller power supply: 500VACrms, for 1 minute Between analog input channels: 1000VACrms, for 1 minute	○	
	Between the I/O terminal and programmable controller power supply: 500VDC, 10MΩ or more Between analog input channels: 500VDC, 10MΩ or more	○	
	16 points (I/O assignment: intelligent 16 points)	△	I/O occupied points has changed to 16 points.
	40-pin connector	×	Wiring change is required.
	Within 0.3mm ²	×	
	-	×	
	0.46A	△	The recalculation of internal current consumption [5VDC] is required.
	0.16kg	○	

2.4.2 Function comparison

○ : With functions, - : Without functions

Item	Description	A68AD	Q68AD-G	Precautions for replacement
A/D conversion enable/disable	Specifies whether to enable or disable the A/D conversion for each channel. By disabling the conversion for the channels that are not used, the sampling time can be shortened.	○	○	
Sampling processing	The A/D conversion for analog input values is performed successively for each channel, and the digital output value is output upon each conversion.	○	○	
Averaging processing	For each channel, A/D conversion values are averaged for the set number of times or set amount of time, and the average value is output as a digital value.	○	○	The setting range of average time and count differ. Refer to Q68AD-G [User's Manual] and then, confirm the specifications.
	Moving average takes the average of the specified number of digital output values measured per sampling time.	-	○	
Primary delay filter	A digital output value is smoothed according to the preset time constant.	-	○	
Maximum and minimum values hold function	The maximum and minimum values of the digital output values are retained in the module.	-	○	
Resolution mode	The resolution can be switched according to the application. The resolution mode is batch-set for all the channels.*1	-	○	
Input signal error detection function	The voltage/current outside the setting range is detected.	-	○	
Warning output function	(1) Process alarm A warning is output if a digital output value falls outside the setting range.	-	○	
	(2) Rate alarm A warning is output if the varying rate of a digital output value falls outside the preset varying rate range.			
Scaling function	Conversion of A/D conversion values to preset percentage values and loading into the buffer memory is available. Programming steps for the scaling can be eliminated.	-	○	
Online module change	A module change is made without the system being stopped.	-	○	Replaceable modules during online are a process CPU and a redundant CPU.

*1 For the A68AD, the resolution for voltage is 1/2000 and that for current is 1/1000 (fixed).
For the Q68AD-G, the resolution for voltage and current is 1/4000 in the normal resolution mode, while the resolution for the voltage from -10 to 10V is 1/16000 and the resolution for the voltage in other ranges and current is 1/12000 in the high resolution mode.

2.4.3 I/O signal comparison to programmable controller CPU

Sequence program change is required as the I/O signals differ.

For details of the I/O signals or sequence program, refer to the Channel Isolated Analog-Digital Converter Module, Channel Isolated Analog-Digital Converter Module (With Signal Conditioning Function) User's Manual.

A68AD				Q68AD-G			
Device No.	Signal name	Device No.	Signal name	Device No.	Signal name	Device No.	Signal name
X0	Watchdog timer error	Y0	Not used	X0	Module READY	Y0	Not used
X1	A/D conversion READY	Y1		X1	Not used	Y1	
X2	Not used	Y2		X2		Y2	
X3		Y3		X3		Y3	
X4		Y4		X4		Y4	
X5		Y5		X5		Y5	
X6		Y6		X6		Y6	
X7		Y7		X7	High resolution mode status flag	Y7	
X8		Y8		X8	Warming output signal	Y8	
X9		Y9		X9	Operating condition setting completed flag	Y9	Operating condition setting request
XA		YA		XA	Offset/gain setting mode flag	YA	User range write request
XB		YB		XB	Channel change completed flag	YB	Channel change request
XC	YC	XC		Input signal error detection signal	YC	Not used	
XD	Not used	YD		XD	Maximum value/minimum value reset completed flag	YD	Maximum value/minimum value reset request
XE		YE		XE	A/D conversion completed flag	YE	Not used
XF	YF	XF		Error flag	YF	Error clear request	
X10	Y10						
X11	Y11						
X12	Y12						
X13	Y13						
X14	Y14						
X15	Y15						
X16	Y16						
X17	Y17						
X18	Y18						
X19	Y19						
X1A	Y1A						
X1B	Y1B						
X1C	Y1C						
X1D	Y1D						
X1E	Y1E						
X1F	Y1F						

2.4.4 Buffer memory address comparison

Sequence program change is required as the assignment of buffer memory differs.

For details of the buffer memory or sequence program, refer to the Channel Isolated Analog-Digital Converter Module, Channel Isolated Analog-Digital Converter Module (With Signal Conditioning Function) User's Manual.

A68AD			Q68AD-G			
Address (Dec.)	Name	Read/write	Address (Dec.)	Name	Read/write	
0	Number of channels	R/W	0	A/D conversion enable/disable	R/W	
1	Averaging processing specification		1	CH1 Average time/Average number of times/ Moving average/Time constant settings		
2	CH1 Averaging time, count		2	CH2 Average time/Average number of times/ Moving average/Time constant settings		
3	CH2 Averaging time, count		3	CH3 Average time/Average number of times/ Moving average/Time constant settings		
4	CH3 Averaging time, count		4	CH4 Average time/Average number of times/ Moving average/Time constant settings		
5	CH4 Averaging time, count		5	CH5 Average time/Average number of times/ Moving average/Time constant settings		
6	CH5 Averaging time, count		6	CH6 Average time/Average number of times/ Moving average/Time constant settings		
7	CH6 Averaging time, count		7	CH7 Average time/Average number of times/ Moving average/Time constant settings		
8	CH7 Averaging time, count		8	CH8 Average time/Average number of times/ Moving average/Time constant settings		
9	CH8 Averaging time, count	R	9	System area (Not used)	-	
10	CH1 Digital output value		10	A/D conversion completed flag	R	
11	CH2 Digital output value		11	CH1 Digital output value		
12	CH3 Digital output value		12	CH2 Digital output value		
13	CH4 Digital output value		13	CH3 Digital output value		
14	CH5 Digital output value		14	CH4 Digital output value		
15	CH6 Digital output value		15	CH5 Digital output value		
16	CH7 Digital output value		16	CH6 Digital output value		
17	CH8 Digital output value		17	CH7 Digital output value		
18	System area (Not used)	-	18	CH8 Digital output value		R/W
19			19	Error code		
20			20	Setting range (CH1 to CH4)		
21			21	Setting range (CH5 to CH8)		
22			22	Offset/gain setting mode Offset specification		
23			23	Offset/gain setting mode Gain specification		
24			24	Averaging process specification (CH1 to CH4)		
25			25	Averaging process specification (CH5 to CH8)		
26			26	System area (Not used)	-	
27			27			
28	28					
29	29					
30	Write data error code	R/W	30	CH1 Maximum value	R	
31			31	CH1 Minimum value		
32			32	CH2 Maximum value		
33			33	CH2 Minimum value		
34			34	CH3 Maximum value		
				to		
		44	CH8 Maximum value			
		45	CH8 Minimum value			

Q68AD-G		
Address (Dec.)	Name	Read/write
46	System area (Not used)	-
47	Input signal error detection extended/input signal error detection setting	R/W
48	Warning output setting	
49	Input signal error detection flag	R
50	Warning output flag (Process alarm)	
51	Warning output flag (Rate alarm)	-
52	System area (Not used)	
53	Scaling enable/disable setting	R/W
54	CH1 Scaling value	R
to		
61	CH8 Scaling value	R/W
62	CH1 Scaling lower limit value	
63	CH1 Scaling upper limit value	
to		
76	CH8 Scaling lower limit value	
77	CH8 Scaling upper limit value	
to		
86	CH1 Process alarm lower lower limit value	
87	CH1 Process alarm lower upper limit value	
88	CH1 Process alarm upper lower limit value	
89	CH1 Process alarm upper upper limit value	
to		
114	CH8 Process alarm lower lower limit value	
115	CH8 Process alarm lower upper limit value	
116	CH8 Process alarm upper lower limit value	
117	CH8 Process alarm upper upper limit value	
118	CH1 Rate alarm warning detection period	
to		
125	CH8 Rate alarm warning detection period	
126	CH1 Rate alarm upper limit value	
127	CH1 Rate alarm lower limit value	
to		
140	CH8 Rate alarm upper limit value	
141	CH8 Rate alarm lower limit value	
142	CH1 Input signal error detection setting value/CH1 Input signal error detection lower limit setting value	
to		
150	CH1 Input signal error detection upper limit setting value	
to		
158	Mode switching setting	R/W
159		
to		
200	Save data classification setting	R/W
201	System area (Not used)	-
202	CH1 Factory default offset value	R/W
203	CH1 Factory default gain value	
to		
232	CH8 Factory default offset value	
233	CH8 Factory default gain value	

2.5 A68AD-S2 (Upgrade to Q68ADV, Q68ADI)

2.5.1 Performance comparison

Item		A68AD-S2												
Analog input	Voltage	-10 to 0 to +10VDC (Input resistance value: Hardware version K or later: 1MΩ, Hardware version J or earlier: 30kΩ)												
	Current	+4 to +20mADC (Input resistance value: 250Ω) *Usable current input: -20 to 0 to 20mA												
Digital output		16-bit signed binary (-2048 to +2047)												
I/O characteristics		<table border="1"> <thead> <tr> <th>Analog input</th> <th>Digital output</th> </tr> </thead> <tbody> <tr> <td>+10V</td> <td>+2000</td> </tr> <tr> <td>+5V or +20mA</td> <td>+1000</td> </tr> <tr> <td>0V or +4mA</td> <td>±0</td> </tr> <tr> <td>-5V or -12mA</td> <td>-1000</td> </tr> <tr> <td>-10V</td> <td>-2000</td> </tr> </tbody> </table>	Analog input	Digital output	+10V	+2000	+5V or +20mA	+1000	0V or +4mA	±0	-5V or -12mA	-1000	-10V	-2000
Analog input	Digital output													
+10V	+2000													
+5V or +20mA	+1000													
0V or +4mA	±0													
-5V or -12mA	-1000													
-10V	-2000													
Maximum resolution		Voltage: 5mV (1/2000) Current: 20μA (1/1000)												
Overall accuracy (Accuracy in respect to maximum digital output value)		Within ±1% (±20)												

○: Compatible, △: Partial change required, ×: Incompatible

		Q68ADV	Q68ADI		Compatibility	Precautions for replacement																																																													
		-10 to 10VDC (Input resistance value: 1MΩ)	-		△	The voltage/current cannot be mixed for one module.																																																													
		-	0 to 20mADC (Input resistance value: 250Ω)																																																																
16-bit signed binary (Normal resolution mode: -4096 to 4095, High resolution mode: -12288 to 12287, -16384 to 16383)					○																																																														
		<table border="1"> <thead> <tr> <th colspan="2" rowspan="2">Analog input range</th> <th colspan="2">Normal resolution mode</th> <th colspan="2">High resolution mode</th> </tr> <tr> <th>Digital output value</th> <th>Maximum resolution</th> <th>Digital output value</th> <th>Maximum resolution</th> </tr> </thead> <tbody> <tr> <td rowspan="5">Voltage</td> <td>0 to 10V</td> <td rowspan="3">0 to 4000</td> <td>2.5mV</td> <td rowspan="2">0 to 16000</td> <td>0.625mV</td> </tr> <tr> <td>0 to 5V</td> <td>1.25mV</td> <td rowspan="2">0 to 12000</td> <td>0.416mV</td> </tr> <tr> <td>1 to 5V</td> <td>1.0mV</td> <td>0.333mV</td> </tr> <tr> <td>-10 to 10V</td> <td rowspan="2">-4000 to 4000</td> <td>2.5mV</td> <td>-16000 to 16000</td> <td>0.625mV</td> </tr> <tr> <td>User range settings</td> <td>0.375mV</td> <td>-12000 to 12000</td> <td>0.333mV</td> </tr> <tr> <td rowspan="3">Current</td> <td>0 to 20mA</td> <td rowspan="2">0 to 4000</td> <td>5μA</td> <td rowspan="2">0 to 12000</td> <td>1.66μA</td> </tr> <tr> <td>4 to 20mA</td> <td>4μA</td> <td>1.33μA</td> </tr> <tr> <td>User range settings</td> <td>-4000 to 4000</td> <td>1.37μA</td> <td>-12000 to 12000</td> <td>1.33μA</td> </tr> </tbody> </table>				Analog input range		Normal resolution mode		High resolution mode		Digital output value	Maximum resolution	Digital output value	Maximum resolution	Voltage	0 to 10V	0 to 4000	2.5mV	0 to 16000	0.625mV	0 to 5V	1.25mV	0 to 12000	0.416mV	1 to 5V	1.0mV	0.333mV	-10 to 10V	-4000 to 4000	2.5mV	-16000 to 16000	0.625mV	User range settings	0.375mV	-12000 to 12000	0.333mV	Current	0 to 20mA	0 to 4000	5μA	0 to 12000	1.66μA	4 to 20mA	4μA	1.33μA	User range settings	-4000 to 4000	1.37μA	-12000 to 12000	1.33μA	△	As concept of gain value is changed, refer to [Analog-Digital Converter Module User's Manual] and then, confirm the I/O characteristics.														
Analog input range		Normal resolution mode		High resolution mode																																																															
		Digital output value	Maximum resolution	Digital output value	Maximum resolution																																																														
Voltage	0 to 10V	0 to 4000	2.5mV	0 to 16000	0.625mV																																																														
	0 to 5V		1.25mV		0 to 12000	0.416mV																																																													
	1 to 5V		1.0mV	0.333mV																																																															
	-10 to 10V	-4000 to 4000	2.5mV	-16000 to 16000	0.625mV																																																														
	User range settings		0.375mV	-12000 to 12000	0.333mV																																																														
Current	0 to 20mA	0 to 4000	5μA	0 to 12000	1.66μA																																																														
	4 to 20mA		4μA		1.33μA																																																														
	User range settings	-4000 to 4000	1.37μA	-12000 to 12000	1.33μA																																																														
		<table border="1"> <thead> <tr> <th colspan="2" rowspan="3">Analog input range</th> <th colspan="3">Normal resolution mode</th> <th colspan="3">High resolution mode</th> </tr> <tr> <th colspan="2">Ambient temperature 0 to 55°C</th> <th rowspan="2">Ambient temperature 25±5°C</th> <th colspan="2">Ambient temperature 0 to 55°C</th> <th rowspan="2">Ambient temperature 25±5°C</th> </tr> <tr> <th>With temperature drift compensation</th> <th>Without temperature drift compensation</th> <th>With temperature drift compensation</th> <th>Without temperature drift compensation</th> </tr> </thead> <tbody> <tr> <td rowspan="4">Voltage</td> <td>0 to 10V</td> <td rowspan="4">±0.3% (±12 digits)</td> <td rowspan="4">±0.4% (±16 digits)</td> <td rowspan="4">±0.1% (±4 digits)</td> <td>±0.3% (±48 digits)</td> <td>±0.4% (±64 digits)</td> <td>±0.1% (±16 digits)</td> </tr> <tr> <td>-10 to 10V</td> <td></td> <td></td> <td></td> </tr> <tr> <td>0 to 5V</td> <td></td> <td></td> <td></td> </tr> <tr> <td>1 to 5V</td> <td></td> <td></td> <td></td> </tr> <tr> <td rowspan="3">Current</td> <td>User range settings</td> <td></td> <td></td> <td></td> <td>±0.3% (±36 digits)</td> <td>±0.4% (±48 digits)</td> <td>±0.1% (±12 digits)</td> </tr> <tr> <td>0 to 20mA</td> <td></td> <td></td> <td></td> <td></td> <td></td> <td></td> </tr> <tr> <td>4 to 20mA</td> <td></td> <td></td> <td></td> <td></td> <td></td> <td></td> </tr> </tbody> </table>				Analog input range		Normal resolution mode			High resolution mode			Ambient temperature 0 to 55°C		Ambient temperature 25±5°C	Ambient temperature 0 to 55°C		Ambient temperature 25±5°C	With temperature drift compensation	Without temperature drift compensation	With temperature drift compensation	Without temperature drift compensation	Voltage	0 to 10V	±0.3% (±12 digits)	±0.4% (±16 digits)	±0.1% (±4 digits)	±0.3% (±48 digits)	±0.4% (±64 digits)	±0.1% (±16 digits)	-10 to 10V				0 to 5V				1 to 5V				Current	User range settings				±0.3% (±36 digits)	±0.4% (±48 digits)	±0.1% (±12 digits)	0 to 20mA							4 to 20mA							○	
Analog input range		Normal resolution mode			High resolution mode																																																														
		Ambient temperature 0 to 55°C		Ambient temperature 25±5°C	Ambient temperature 0 to 55°C			Ambient temperature 25±5°C																																																											
		With temperature drift compensation	Without temperature drift compensation		With temperature drift compensation	Without temperature drift compensation																																																													
Voltage	0 to 10V	±0.3% (±12 digits)	±0.4% (±16 digits)	±0.1% (±4 digits)	±0.3% (±48 digits)	±0.4% (±64 digits)	±0.1% (±16 digits)																																																												
	-10 to 10V																																																																		
	0 to 5V																																																																		
	1 to 5V																																																																		
Current	User range settings				±0.3% (±36 digits)	±0.4% (±48 digits)	±0.1% (±12 digits)																																																												
	0 to 20mA																																																																		
	4 to 20mA																																																																		

Item	A68AD-S2	
Maximum conversion speed	Max. 2.5ms/channel	
Absolute maximum input	Voltage: ±15V Current: ±30mA	
Analog input points	8 channels/module	
Maximum number of writes for E ² PROM	-	
Isolation method	Between the input terminal and programmable controller power supply: photocoupler isolation Between channels: non-isolated	
Dielectric withstand voltage	-	
Insulation resistance	-	
Occupied I/O points	32 points (I/O assignment: special 32 points)	
Connected terminal	38-point terminal block	
Applicable wire size	0.75 to 2mm ² (Applicable tightening torque: 39 to 59N·cm)	
Applicable solderless terminal	V1.25-3, V1.25-YS3A, V2-S3, V2-YS3A	
Internal current consumption (5VDC)	Hardware version K or later: 0.39A Hardware version J or earlier: 0.9A	
Weight	Hardware version K or later: 0.3kg Hardware version J or earlier: 0.6kg	

○ : Compatible, △ : Partial change required, × : Incompatible

	Q68ADV	Q68ADI	Compatibility	Precautions for replacement
	80μs/channel (When there is temperature drift compensation, the time calculated by adding 160 μs will be used regardless of the number of channels used.)		○	The conversion speed of Q68ADV/I to A68AD-S2 has become quick. And then, on A68AD-S2, the noise that did not import on Q68ADV/I can be imported as analog signal. In this case, use the averaging processing function to remove the effect of noise.
	±15V	±30mA	○	
	8 channels/module		○	
	Max. 100,000 times		○	
	Between the I/O terminal and programmable controller power supply: photocoupler isolation Between channels: non-isolated		○	
	Between the I/O terminal and programmable controller power supply: 500VAC, for 1 minute		○	
	Between the I/O terminal and programmable controller power supply: 500VDC, 20MΩ or more		○	
	16 points (I/O assignment: intelligent 16 points)		△	I/O occupied points has changed to 16 points.
	18-point terminal block		×	Wiring change is required.
	0.3 to 0.75mm ²		×	
	R1.25-3 (A solderless terminal with sleeve can not be used.)		×	
	0.64A	0.64A	△	The recalculation of internal current consumption [5VDC] is required.
	0.19kg	0.19kg	○	

2.5.2 Function comparison

○ : With functions, - : Without functions

Item	Description	A68AD-S2	Q68ADV/I	Precautions for replacement
A/D conversion enable/disable	Specifies whether to enable or disable the A/D conversion for each channel. By disabling the conversion for the channels that are not used, the sampling time can be shortened.	○	○	
Sampling processing	The A/D conversion for analog input values is performed successively for each channel, and the digital output value is output upon each conversion.	○	○	The sampling processing time changes depending on the number of channels used (number of channels set to A/D conversion enable) and whether, with or without the temperature drift compensation function. (a) Without temperature drift compensation function (processing time) = (number of channels used) × 80 (μs /1 channel) (b) With temperature drift compensation function (processing time)= (number of channels used) × 80 (μs /1 channel) + 160μs
Averaging processing	For each channel, A/D conversion values are averaged for the set number of times or set amount of time, and the average value is output as a digital value.	○	○	The setting range of average time and count differ. Refer to [Analog-Digital Converter Module User's Manual] and then, confirm the specifications.
Maximum and minimum values hold function	The maximum and minimum values of the digital output values are retained in the module.	-	○	
Temperature drift compensation function	Errors arising from changes in the ambient temperature of the module are automatically compensated for to improve conversion accuracy. The temperature drift compensation function can be performed at (A/D conversion time for all channels) + 160μs.	-	○	
Resolution mode	The resolution settings of 1/4000, 1/12000 or 1/16000 can be selected according to the application. The resolution mode setting is applicable to all channels.	-	○	
Online module change	A module change is made without the system being stopped.	-	○	Replaceable modules during online are a process CPU and a redundant CPU.

2.5.3 I/O signal comparison to programmable controller CPU

Sequence program change is required as the I/O signals differ.

For details of the I/O signals or sequence program, refer to the Analog-Digital Converter Module User's Manual.

A68AD-S2				Q68ADV/I			
Device No.	Signal name	Device No.	Signal name	Device No.	Signal name	Device No.	Signal name
X0	Watchdog timer error	Y0	Not used	X0	Module READY	Y0	Not used
X1	A/D conversion READY	Y1		X1	Temperature drift compensation flag	Y1	
X2	Not used	Y2		X2	Not used	Y2	
X3		Y3		X3		Y3	
X4		Y4		X4		Y4	
X5		Y5		X5		Y5	
X6		Y6		X6		Y6	
X7		Y7		X7		Y7	
X8		Y8		X8		High resolution mode status flag	Y8
X9		Y9		X9	Operating condition setting completed flag	Y9	Operating condition setting request
XA		YA		XA	Offset/gain setting mode flag	YA	User range write request
XB		YB		XB	Channel change completed flag	YB	Channel change request
XC		YC		XC	Not used	YC	Not used
XD		YD		XD	Maximum value/minimum value reset completed flag	YD	Maximum value/minimum value reset request
XE		YE		XE	A/D conversion completed flag	YE	Not used
XF	YF	XF		Error flag	YF	Error clear request	
X10	Y10						
X11	Y11						
X12	Y12						
X13	Y13						
X14	Y14						
X15	Y15						
X16	Y16						
X17	Y17						
X18	Y18						
X19	Y19						
X1A	Y1A						
X1B	Y1B						
X1C	Y1C						
X1D	Y1D						
X1E	Y1E						
X1F	Y1F						

2.5.4 Buffer memory address comparison

Sequence program change is required as the assignment of buffer memory differs.

For details of the buffer memory or sequence program, refer to the Analog-Digital Converter Module User's Manual.

A68AD-S2			Q68ADV/I		
Address (Dec.)	Name	Read/write	Address (Dec.)	Name	Read/write
0	Used channel specification	R/W	0	A/D conversion enable/disable	R/W
1	Averaging processing specification		1	CH1 Time/count averaging setting	
2	CH1 Averaging time, count		2	CH2 Time/count averaging setting	
3	CH2 Averaging time, count		3	CH3 Time/count averaging setting	
4	CH3 Averaging time, count		4	CH4 Time/count averaging setting	
5	CH4 Averaging time, count		5	CH5 Time/count averaging setting	
6	CH5 Averaging time, count		6	CH6 Time/count averaging setting	
7	CH6 Averaging time, count		7	CH7 Time/count averaging setting	
8	CH7 Averaging time, count		8	CH8 Time/count averaging setting	
9	CH8 Averaging time, count	R	9	Averaging processing specification	R
10	CH1 Digital output value		10	A/D conversion completed flag	
11	CH2 Digital output value		11	CH1 Digital output value	
12	CH3 Digital output value		12	CH2 Digital output value	
13	CH4 Digital output value		13	CH3 Digital output value	
14	CH5 Digital output value		14	CH4 Digital output value	
15	CH6 Digital output value		15	CH5 Digital output value	
16	CH7 Digital output value		16	CH6 Digital output value	
17	CH8 Digital output value		17	CH7 Digital output value	
18	System area (Not used)	-	18	CH8 Digital output value	R/W
19			19	Error code	
20			20	Setting range (CH1 to CH4)	
21			21	Setting range (CH5 to CH8)	
22			22	Offset/gain setting mode Offset specification	
23			23	Offset/gain setting mode Gain specification	
24			24	System area (Not used)	
25			25		
26			26		
27			27		
28			28		
29	29	R			
30	30		CH1 Maximum value		
31	31		CH1 Minimum value		
32	32		CH2 Maximum value		
33	33		CH2 Minimum value		
34	Write data error code	R/W	34	CH3 Maximum value	R
35	A/D conversion completed flag	R	35	CH3 Minimum value	
			36	CH4 Maximum value	
			37	CH4 Minimum value	
			38	CH5 Maximum value	
			39	CH5 Minimum value	
			40	CH6 Maximum value	
			41	CH6 Minimum value	
			42	CH7 Maximum value	
			43	CH7 Minimum value	
			44	CH8 Maximum value	
			45	CH8 Minimum value	

Q68ADV/I		
Address (Dec.)	Name	Read/write
46	System area (Not used)	-
to		
157		
158	Mode switching setting	R/W
159		
160	System area (Not used)	-
to		
201		
202	CH1 Industrial shipment settings offset value	R/W
203	CH1 Industrial shipment settings gain value	
204	CH2 Industrial shipment settings offset value	
205	CH2 Industrial shipment settings gain value	
206	CH3 Industrial shipment settings offset value	
207	CH3 Industrial shipment settings gain value	
208	CH4 Industrial shipment settings offset value	
209	CH4 Industrial shipment settings gain value	
210	CH5 Industrial shipment settings offset value	
211	CH5 Industrial shipment settings gain value	
212	CH6 Industrial shipment settings offset value	
213	CH6 Industrial shipment settings gain value	
214	CH7 Industrial shipment settings offset value	
215	CH7 Industrial shipment settings gain value	
216	CH8 Industrial shipment settings offset value	
217	CH8 Industrial shipment settings gain value	
218	CH1 User range settings offset value	
219	CH1 User range settings gain value	
220	CH2 User range settings offset value	
221	CH2 User range settings gain value	
222	CH3 User range settings offset value	
223	CH3 User range settings gain value	
224	CH4 User range settings offset value	
225	CH4 User range settings gain value	
226	CH5 User range settings offset value	
227	CH5 User range settings gain value	
228	CH6 User range settings offset value	
229	CH6 User range settings gain value	
230	CH7 User range settings offset value	
231	CH7 User range settings gain value	
232	CH8 User range settings offset value	
233	CH8 User range settings gain value	

2.6 A68AD-S2 (Upgrade to Q68AD-G)

2.6.1 Performance comparison

Item		A68AD-S2												
Analog input	Voltage	-10 to 0 to +10VDC (Input resistance value: Hardware version K or later: 1MΩ, Hardware version J or earlier: 30kΩ)												
	Current	+4 to +20mADC (Input resistance value: 250Ω) *Usable current input: -20 to 0 to 20mA												
Digital output		16-bit signed binary (-2048 to +2047)												
I/O characteristics		<table border="1"> <thead> <tr> <th>Analog input</th> <th>Digital output</th> </tr> </thead> <tbody> <tr> <td>+10V</td> <td>+2000</td> </tr> <tr> <td>+5V or +20mA</td> <td>+1000</td> </tr> <tr> <td>0V or +4mA</td> <td>±0</td> </tr> <tr> <td>-5V or -12mA</td> <td>-1000</td> </tr> <tr> <td>-10V</td> <td>-2000</td> </tr> </tbody> </table>	Analog input	Digital output	+10V	+2000	+5V or +20mA	+1000	0V or +4mA	±0	-5V or -12mA	-1000	-10V	-2000
Analog input	Digital output													
+10V	+2000													
+5V or +20mA	+1000													
0V or +4mA	±0													
-5V or -12mA	-1000													
-10V	-2000													
Maximum resolution		Voltage: 5mV (1/2000) Current: 20μA (1/1000)												
Overall accuracy (Accuracy in respect to maximum digital output value)		Within ±1% (±20)												

○: Compatible, △: Partial change required, ×: Incompatible

Q68AD-G		Compatibility	Precautions for replacement																																																							
-10 to 10VDC (Input resistance value: 1MΩ or more)		○																																																								
0 to 20mADC (Input resistance value: 250Ω)																																																										
16-bit signed binary (Normal resolution mode: -4096 to 4095, High resolution mode: -12288 to 12287, -16384 to 16383)		○																																																								
Input	<table border="1"> <thead> <tr> <th rowspan="2">Analog input range</th> <th colspan="2">Normal resolution mode</th> <th colspan="2">High resolution mode</th> </tr> <tr> <th>Digital output value</th> <th>Maximum resolution</th> <th>Digital output value</th> <th>Maximum resolution</th> </tr> </thead> <tbody> <tr> <td rowspan="6">Voltage</td> <td>0 to 10V</td> <td rowspan="3">0 to 4000</td> <td>2.5mV</td> <td>0 to 16000</td> <td>0.625mV</td> </tr> <tr> <td>0 to 5V</td> <td>1.25mV</td> <td rowspan="2">0 to 12000</td> <td>0.416mV</td> </tr> <tr> <td>1 to 5V</td> <td>1.0mV</td> <td>0.333mV</td> </tr> <tr> <td>1 to 5V (Expanded mode)</td> <td>-1000 to 4500</td> <td>1.0mV</td> <td>-3000 to 13500</td> <td>0.333mV</td> </tr> <tr> <td>-10 to 10V</td> <td rowspan="2">-4000 to 4000</td> <td>2.5mV</td> <td>-16000 to 16000</td> <td>0.625mV</td> </tr> <tr> <td>Users range setting</td> <td>0.375mV</td> <td>-12000 to 12000</td> <td>0.333mV</td> </tr> <tr> <td rowspan="4">Current</td> <td>0 to 20mA</td> <td rowspan="2">0 to 4000</td> <td>5μA</td> <td rowspan="2">0 to 12000</td> <td>1.66μA</td> </tr> <tr> <td>4 to 20mA</td> <td>4μA</td> <td>1.33μA</td> </tr> <tr> <td>4 to 20mA (Expanded mode)</td> <td>-1000 to 4500</td> <td>4μA</td> <td>-3000 to 13500</td> <td>1.33μA</td> </tr> <tr> <td>Users range setting</td> <td>-4000 to 4000</td> <td>1.37μA</td> <td>-12000 to 12000</td> <td>1.33μA</td> </tr> </tbody> </table>	Analog input range	Normal resolution mode		High resolution mode		Digital output value	Maximum resolution	Digital output value	Maximum resolution	Voltage	0 to 10V	0 to 4000	2.5mV	0 to 16000	0.625mV	0 to 5V	1.25mV	0 to 12000	0.416mV	1 to 5V	1.0mV	0.333mV	1 to 5V (Expanded mode)	-1000 to 4500	1.0mV	-3000 to 13500	0.333mV	-10 to 10V	-4000 to 4000	2.5mV	-16000 to 16000	0.625mV	Users range setting	0.375mV	-12000 to 12000	0.333mV	Current	0 to 20mA	0 to 4000	5μA	0 to 12000	1.66μA	4 to 20mA	4μA	1.33μA	4 to 20mA (Expanded mode)	-1000 to 4500	4μA	-3000 to 13500	1.33μA	Users range setting	-4000 to 4000	1.37μA	-12000 to 12000	1.33μA	△	As concept of gain value is changed, refer to Q68AD-G [User's Manual] and then, confirm the I/O characteristics.
Analog input range	Normal resolution mode		High resolution mode																																																							
	Digital output value	Maximum resolution	Digital output value	Maximum resolution																																																						
Voltage	0 to 10V	0 to 4000	2.5mV	0 to 16000	0.625mV																																																					
	0 to 5V		1.25mV	0 to 12000	0.416mV																																																					
	1 to 5V		1.0mV		0.333mV																																																					
	1 to 5V (Expanded mode)	-1000 to 4500	1.0mV	-3000 to 13500	0.333mV																																																					
	-10 to 10V	-4000 to 4000	2.5mV	-16000 to 16000	0.625mV																																																					
	Users range setting		0.375mV	-12000 to 12000	0.333mV																																																					
Current	0 to 20mA	0 to 4000	5μA	0 to 12000	1.66μA																																																					
	4 to 20mA		4μA		1.33μA																																																					
	4 to 20mA (Expanded mode)	-1000 to 4500	4μA	-3000 to 13500	1.33μA																																																					
	Users range setting	-4000 to 4000	1.37μA	-12000 to 12000	1.33μA																																																					
±0.1% Normal resolution mode: ±4 digits High resolution mode (0 to 10V, -10 to 10V): ±16 digits High resolution mode (Other than the above ranges): ±12 digits Temperature coefficient: ±71.4ppm/°C (0.00714%/°C)		○																																																								

Item	A68AD-S2	
Maximum conversion speed	Max. 2.5ms/channel	
Response time	-	
Absolute maximum input	Voltage: ±15V Current: ±30mA	
Analog input points	8 channels/module	
Maximum number of writes for E ² PROM	-	
Isolation method	Between the input terminal and programmable controller power supply: photocoupler isolation Between channels: non-isolated	
Dielectric withstand voltage	-	
Insulation resistance	-	
Occupied I/O points	32 points (I/O assignment: special 32 points)	
Connected terminal	38-point terminal block	
Applicable wire size	0.75 to 2mm ² (Applicable tightening torque: 39 to 59N·cm)	
Applicable solderless terminal	V1.25-3, V1.25-YS3A, V2-S3, V2-YS3A	
Internal current consumption (5VDC)	Hardware version K or later: 0.39A Hardware version J or earlier: 0.9A	
Weight	Hardware version K or later: 0.3kg Hardware version J or earlier: 0.6kg	

○ : Compatible, △ : Partial change required, × : Incompatible

	Q68AD-G	Compatibility	Precautions for replacement
	10ms/channel (Sampling cycle)	△	The conversion speed of Q68AD-G to A68AD has become slow. If fast conversion speed is required for control, the Q64AD is recommended.
	20ms		
	Voltage: ±15V current: ±30mA	○	
	8 channels/module	○	
	Up to 50,000 times	○	
	Between the I/O terminal and programmable controller power supply: transformer isolation Between channels: transformer isolation	○	
	Between the I/O terminal and programmable controller power supply: 500VACrms, for 1 minute Between analog input channels: 1000VACrms, for 1 minute	○	
	Between the I/O terminal and programmable controller power supply: 500VDC, 10MΩ or more Between analog input channels: 500VDC, 10MΩ or more	○	
	16 points (I/O assignment: intelligent 16 points)	△	I/O occupied points has changed to 16 points.
	40-pin connector	×	Wiring change is required.
	Within 0.3mm ²	×	
	-	×	
	0.46A	△	The recalculation of internal current consumption [5VDC] is required.
	0.16kg	○	

2.6.2 Function comparison

○ : With functions, - : Without functions

Item	Description	A68AD-S2	Q68AD-G	Precautions for replacement
A/D conversion enable/disable	Specifies whether to enable or disable the A/D conversion for each channel. By disabling the conversion for the channels that are not used, the sampling time can be shortened.	○	○	
Sampling processing	The A/D conversion for analog input values is performed successively for each channel, and the digital output value is output upon each conversion.	○	○	
Averaging processing	For each channel, A/D conversion values are averaged for the set number of times or set amount of time, and the average value is output as a digital value.	○	○	The setting range of average time and count differ. Refer to Q68AD-G [User's Manual] and then, confirm the specifications.
	Moving average takes the average of the specified number of digital output values measured per sampling time.	-	○	
Primary delay filter	A digital output value is smoothed according to the preset time constant.	-	○	
Maximum and minimum values hold function	The maximum and minimum values of the digital output values are retained in the module.	-	○	
Resolution mode	The resolution can be switched according to the application. The resolution mode is batch-set for all the channels.*1	-	○	
Input signal error detection function	The voltage/current outside the setting range is detected.	-	○	
Warning output function	(1) Process alarm A warning is output if a digital output value falls outside the setting range.	-	○	
	(2) Rate alarm A warning is output if the varying rate of a digital output value falls outside the preset varying rate range.			
Scaling function	Conversion of A/D conversion values to preset percentage values and loading into the buffer memory is available. Programming steps for the scaling can be eliminated.	-	○	
Online module change	A module change is made without the system being stopped.	-	○	Replaceable modules during online are a process CPU and a redundant CPU.

*1 For the A68AD-S2, the resolution for voltage is 1/2000 and that for current is 1/1000 (fixed).
For the Q68AD-G, the resolution for voltage and current is 1/4000 in the normal resolution mode, while the resolution for the voltage from -10 to 10V is 1/16000 and the resolution for the voltage in other ranges and current is 1/12000 in the high resolution mode.

2.6.3 I/O signal comparison to programmable controller CPU

Sequence program change is required as the I/O signals differ.

For details of the I/O signals or sequence program, refer to the Channel Isolated Analog-Digital Converter Module, Channel Isolated Analog-Digital Converter Module (With Signal Conditioning Function) User's Manual.

A68AD-S2				Q68AD-G				
Device No.	Signal name	Device No.	Signal name	Device No.	Signal name	Device No.	Signal name	
X0	Watchdog timer error	Y0	Not used	X0	Module READY	Y0	Not used	
X1	A/D conversion READY	Y1		X1	Not used	Y1		
X2	Not used	Y2		X2		Y2		
X3		Y3		X3		Y3		
X4		Y4		X4		Y4		
X5		Y5		X5		Y5		
X6		Y6		X6		Y6		
X7		Not used		Y7	X7	High resolution mode status flag	Y7	Not used
X8	Y8			X8	Warming output signal	Y8		
X9	Y9			X9	Operating condition setting completed flag	Y9	Operating condition setting request	
XA	YA			XA	Offset/gain setting mode flag	YA	User range write request	
XB	YB			XB	Channel change completed flag	YB	Channel change request	
XC	YC			XC	Input signal error detection signal	YC	Not used	
XD	YD			XD	Maximum value/minimum value reset completed flag	YD	Maximum value/minimum value reset request	
XE	YE			XE	A/D conversion completed flag	YE	Not used	
XF	YF			XF	Error flag	YF	Error clear request	
X10	Y10							
X11	Y11							
X12	Y12							
X13	Y13							
X14	Y14							
X15	Y15							
X16	Y16							
X17	Y17							
X18	Y18							
X19	Y19							
X1A	Y1A							
X1B	Y1B							
X1C	Y1C							
X1D	Y1D							
X1E	Y1E							
X1F	Y1F							

2.6.4 Buffer memory address comparison

Sequence program change is required as the assignment of buffer memory differs.

For details of the I/O signals or sequence program, refer to the Channel Isolated Analog-Digital Converter Module, Channel Isolated Analog-Digital Converter Module (With Signal Conditioning Function) User's Manual.

A68AD-S2			Q68AD-G		
Address (Dec.)	Name	Read/write	Address (Dec.)	Name	Read/write
0	Used channel specification	R/W	0	A/D conversion enable/disable	R/W
1	Averaging processing specification		1	CH1 Average time/Average number of times/ Moving average/Time constant settings	
2	CH1 Averaging time, count		2	CH2 Average time/Average number of times/ Moving average/Time constant settings	
3	CH2 Averaging time, count		3	CH3 Average time/Average number of times/ Moving average/Time constant settings	
4	CH3 Averaging time, count		4	CH4 Average time/Average number of times/ Moving average/Time constant settings	
5	CH4 Averaging time, count		5	CH5 Average time/Average number of times/ Moving average/Time constant settings	
6	CH5 Averaging time, count		6	CH6 Average time/Average number of times/ Moving average/Time constant settings	
7	CH6 Averaging time, count		7	CH7 Average time/Average number of times/ Moving average/Time constant settings	
8	CH7 Averaging time, count		8	CH8 Average time/Average number of times/ Moving average/Time constant settings	
9	CH8 Averaging time, count	R	9	System area (Not used)	-
10	CH1 Digital output value		10	A/D conversion completed flag	R
11	CH2 Digital output value		11	CH1 Digital output value	
12	CH3 Digital output value		12	CH2 Digital output value	
13	CH4 Digital output value		13	CH3 Digital output value	
14	CH5 Digital output value		14	CH4 Digital output value	
15	CH6 Digital output value		15	CH5 Digital output value	
16	CH7 Digital output value		16	CH6 Digital output value	
17	CH8 Digital output value		17	CH7 Digital output value	
18	System area (Not used)	-	18	CH8 Digital output value	
19			19	Error code	
20			20	Setting range (CH1 to CH4)	
21			21	Setting range (CH5 to CH8)	
22			22	Offset/gain setting mode Offset specification	
23			23	Offset/gain setting mode Gain specification	
24			24	Averaging process specification (CH1 to CH4)	
25			25	Averaging process specification (CH5 to CH8)	
26			26	System area (Not used)	
27			27		
28	28				
29	29				
30	Write data error code	R/W	30	CH1 Maximum value	R
31			31	CH1 Minimum value	
32			32	CH2 Maximum value	
33			33	CH2 Minimum value	
34			34	CH3 Maximum value	
35			35	to	
			44	CH8 Maximum value	
			45	CH8 Minimum value	

Q68AD-G		
Address (Dec.)	Name	Read/write
46	System area (Not used)	-
47	Input signal error detection extended/input signal error detection setting	R/W
48	Warning output setting	
49	Input signal error detection flag	R
50	Warning output flag (Process alarm)	
51	Warning output flag (Rate alarm)	
52	System area (Not used)	-
53	Scaling enable/disable setting	R/W
54	CH1 Scaling value	R
to		
61	CH8 Scaling value	R/W
62	CH1 Scaling lower limit value	
63	CH1 Scaling upper limit value	
to		
76	CH8 Scaling lower limit value	
77	CH8 Scaling upper limit value	
to		
86	CH1 Process alarm lower lower limit value	
87	CH1 Process alarm lower upper limit value	
88	CH1 Process alarm upper lower limit value	
89	CH1 Process alarm upper upper limit value	
to		
114	CH8 Process alarm lower lower limit value	
115	CH8 Process alarm lower upper limit value	
116	CH8 Process alarm upper lower limit value	
117	CH8 Process alarm upper upper limit value	
118	CH1 Rate alarm warning detection period	
to		
125	CH8 Rate alarm warning detection period	
126	CH1 Rate alarm upper limit value	
127	CH1 Rate alarm lower limit value	
to		
140	CH8 Rate alarm upper limit value	
141	CH8 Rate alarm lower limit value	
142	CH1 Input signal error detection setting value/CH1 Input signal error detection lower limit setting value	
to		
150	CH1 Input signal error detection upper limit setting value	
to		
158	Mode switching setting	R/W
159		
to		
200	Save data classification setting	R/W
201	System area (Not used)	-
202	CH1 Factory default offset value	R/W
203	CH1 Factory default gain value	
to		
232	CH8 Factory default offset value	
233	CH8 Factory default gain value	

2.7 A68ADN (Upgrade to Q68ADV, Q68ADI)

2.7.1 Performance comparison

Item		A68ADN																											
Analog input	Voltage	-10 to 0 to +10VDC (Input resistance value: 1MΩ)																											
	Current	-20 to 0 to +20mADC (Input resistance value: 250Ω)																											
Digital output		16-bit signed binary When 1/4000 is set: -4096 to +4095 When 1/8000 is set: -8192 to +8191 When 1/12000 is set: -12288 to +12287																											
I/O characteristics		<table border="1"> <thead> <tr> <th rowspan="2">Analog input</th> <th colspan="3">Digital output value (When gain 5V/20mA, offset 0V/0mA)</th> </tr> <tr> <th>1/4000</th> <th>1/8000</th> <th>1/12000</th> </tr> </thead> <tbody> <tr> <td>+10V</td> <td>+4000</td> <td>+8000</td> <td>+12000</td> </tr> <tr> <td>+5V or +20mA</td> <td>+2000</td> <td>+4000</td> <td>+6000</td> </tr> <tr> <td>0V or 20mA</td> <td>0</td> <td>0</td> <td>0</td> </tr> <tr> <td>-5V or -20mA</td> <td>-2000</td> <td>-4000</td> <td>-6000</td> </tr> <tr> <td>-10V</td> <td>-4000</td> <td>-8000</td> <td>-12000</td> </tr> </tbody> </table> <p>(Factory-set: gain...5V, offset...0V)</p>	Analog input	Digital output value (When gain 5V/20mA, offset 0V/0mA)			1/4000	1/8000	1/12000	+10V	+4000	+8000	+12000	+5V or +20mA	+2000	+4000	+6000	0V or 20mA	0	0	0	-5V or -20mA	-2000	-4000	-6000	-10V	-4000	-8000	-12000
Analog input	Digital output value (When gain 5V/20mA, offset 0V/0mA)																												
	1/4000	1/8000	1/12000																										
+10V	+4000	+8000	+12000																										
+5V or +20mA	+2000	+4000	+6000																										
0V or 20mA	0	0	0																										
-5V or -20mA	-2000	-4000	-6000																										
-10V	-4000	-8000	-12000																										
Maximum resolution		<table border="1"> <thead> <tr> <th></th> <th>1/4000</th> <th>1/8000</th> <th>1/12000</th> </tr> </thead> <tbody> <tr> <td>Voltage input</td> <td>2.5mV</td> <td>1.25mV</td> <td>0.83mV</td> </tr> <tr> <td>Current input</td> <td>10μA</td> <td>5μA</td> <td>3.33μA</td> </tr> </tbody> </table>		1/4000	1/8000	1/12000	Voltage input	2.5mV	1.25mV	0.83mV	Current input	10μA	5μA	3.33μA															
	1/4000	1/8000	1/12000																										
Voltage input	2.5mV	1.25mV	0.83mV																										
Current input	10μA	5μA	3.33μA																										
Overall accuracy (Accuracy in respect to maximum digital output value)		<table border="1"> <thead> <tr> <th></th> <th>1/4000</th> <th>1/8000</th> <th>1/12000</th> </tr> </thead> <tbody> <tr> <td>±1%</td> <td>±40</td> <td>±80</td> <td>±120</td> </tr> </tbody> </table>		1/4000	1/8000	1/12000	±1%	±40	±80	±120																			
	1/4000	1/8000	1/12000																										
±1%	±40	±80	±120																										

○ : Compatible, △ : Partial change required, × : Incompatible

Q68ADV		Q68ADI				Compatibility	Precautions for replacement	
-10 to 10VDC (Input resistance value: 1MΩ)		-				△	The voltage/current cannot be mixed for one module.	
-		0 to 20mADC (Input resistance value: 250Ω)						
16-bit signed binary (Normal resolution mode: -4096 to 4095, High resolution mode: -12288 to 12287, -16384 to 16383)						○		
Analog input range		Normal resolution mode		High resolution mode		△	As concept of gain value is changed, refer to [Analog-Digital Converter Module User's Manual] and then, confirm the I/O characteristics.	
		Digital output value	Maximum resolution	Digital output value	Maximum resolution			
Voltage	0 to 10V	0 to 4000	2.5mV	0 to 16000	0.625mV			
	0 to 5V		1.25mV	0 to 12000	0.416mV			
	1 to 5V		1.0mV		0.333mV			
	-10 to 10V	-4000 to 4000	2.5mV	-16000 to 16000	0.625mV			
	User range settings		0.375mV	-12000 to 12000	0.333mV			
Current	0 to 20mA	0 to 4000	5μA	0 to 12000	1.66μA			
	4 to 20mA		4μA		1.33μA			
	User range settings	-4000 to 4000	1.37μA	-12000 to 12000	1.33μA			
Analog input range		Normal resolution mode		High resolution mode			○	
		Ambient temperature 0 to 55°C		Ambient temperature 0 to 55°C		Ambient temperature 25±5°C		
		With temperature drift compensation	Without temperature drift compensation	Ambient temperature 25±5°C	With temperature drift compensation	Without temperature drift compensation		
Voltage	0 to 10V	±0.3% (±12 digits)	±0.4% (±16 digits)	±0.1% (±4 digits)	±0.3% (±48 digits)	±0.4% (±64 digits)		±0.1% (±16 digits)
	-10 to 10V				±0.3% (±36 digits)	±0.4% (±48 digits)		±0.1% (±12 digits)
	0 to 5V							
	1 to 5V							
User range settings								
Current	0 to 20mA							
	4 to 20mA							
	User range settings							

Item	A68ADN	
Maximum conversion speed	20ms/channel	
Absolute maximum input	Voltage: ±15V Current: ±30mA	
Analog input points	8 channel/module	
Maximum number of writes for E ² PROM	-	
Isolation method	Between the input terminal and programmable controller power supply: photocoupler isolation Between channels: non-isolated	
Dielectric withstand voltage	Between the I/O terminal and programmable controller power supply: 500VAC, for 1 minute	
Insulation resistance	Between the I/O terminal and programmable controller power supply: 500VDC, 5MΩ or more	
Occupied I/O points	32 points (I/O assignment: special 32 points)	
Connected terminal	38-point terminal block	
Applicable wire size	0.75 to 2mm ² (Applicable tightening torque: 39 to 59N•cm)	
Applicable solderless terminal	V1.25-3, V1.25-YS3A, V2-S3, V2-YS3A	
Internal current consumption (5VDC)	0.4A	
Weight	0.51kg	

Q68ADV		Q68ADI	Compatibility	Precautions for replacement
80μs/channel (When there is temperature drift compensation, the time calculated by adding 160 μs will be used regardless of the number of channels used.)			○	The conversion speed of Q68ADV/I to A68ADN has become quick. And then, on Q68ADV/I, the noise that did not import on A68ADN can be imported as analog signal. In this case, use the averaging processing function to remove the effect of noise.
±15V		±30mA	○	
8 channels/module			○	
Max. 100,000 times			○	
Between the I/O terminal and programmable controller power supply: photocoupler isolation Between channels: non-isolated			○	
Between the I/O terminal and programmable controller power supply: 500VAC, for 1 minute			○	
Between the I/O terminal and programmable controller power supply: 500VDC, 5MΩ or more			○	
16 points (I/O assignment: intelligent 16 points)			△	I/O occupied points has changed to 16 points.
18-point terminal block			×	Wiring change is required.
0.3 to 0.75mm ²			×	
R1.25-3 (A solderless terminal with sleeve can not be used.)			×	
0.64A		0.64A	△	The recalculation of internal current consumption [5VDC] is required.
0.19kg		0.19kg	○	

2.7.2 Function comparison

○ : With functions, - : Without functions

Item	Description	A68ADN	Q68ADV/I	Precautions for replacement
A/D conversion enable/disable	Specifies whether to enable or disable the A/D conversion for each channel. By disabling the conversion for the channels that are not used, the sampling time can be shortened.	○	○	
Sampling processing	The A/D conversion for analog input values is performed successively for each channel, and the digital output value is output upon each conversion.	○	○	The sampling processing time changes depending on the number of channels used (number of channels set to A/D conversion enable) and whether, with or without the temperature drift compensation function. (a) Without temperature drift compensation function (processing time) = (number of channels used) × 80 (μs / 1 channel) (b) With temperature drift compensation function (processing time) = (number of channels used) × 80 (μs / 1 channel) + 160μs
Averaging processing	For each channel, A/D conversion values are averaged for the set number of times or set amount of time, and the average value is output as a digital value.	○	○	The setting range of average time and count differ. Refer to [Analog-Digital Converter Module User's Manual] and then, confirm the specifications.
Maximum and minimum values hold function	The maximum and minimum values of the digital output values are retained in the module.	-	○	
Temperature drift compensation function	Errors arising from changes in the ambient temperature of the module are automatically compensated for to improve conversion accuracy. The temperature drift compensation function can be performed at (A/D conversion time for all channels) + 160μs.	-	○	
Resolution mode	The resolution can be switched according to the application. The resolution mode is batch-set for all the channels.*1	○	○	
Online module change	A module change is made without the system being stopped.	-	○	Replaceable modules during online are a process CPU and a redundant CPU.

*1 For the A68ADN, the resolution for voltage and current can be set to 1/4000, 1/8000, or 1/12000.
For the Q68ADV/I, the resolution for voltage and current is 1/4000 in the normal resolution mode, while the resolution for the voltage from -10 to 10V is 1/16000 and the resolution for the voltage in other ranges and current is 1/12000 in the high resolution mode.

2.7.3 I/O signal comparison to programmable controller CPU

Sequence program change is required as the I/O signals differ.

For details of the I/O signals or sequence program, refer to the Analog-Digital Converter Module User's Manual.

A68ADN				Q68ADV/I					
Device No.	Signal name	Device No.	Signal name	Device No.	Signal name	Device No.	Signal name		
X0	Watchdog timer error	Y0	Not used	X0	Module READY	Y0	Not used		
X1	A/D conversion READY	Y1		X1	Temperature drift compensation flag	Y1			
X2	Error flag	Y2		X2	Not used	Y2			
X3	Not used	Y3		X3		Y3			
X4		Y4		X4		Y4			
X5		Y5		X5		Y5			
X6		Y6		X6		Y6			
X7		Y7		X7		Y7			
X8		Y8		X8		High resolution mode status flag		Y8	
X9		Y9		X9	Operating condition setting completed flag	Y9		Operating condition setting request	
XA	YA	XA		Offset/gain setting mode flag	YA	User range write request			
XB	YB	XB		Channel change completed flag	YB	Channel change request			
XC	YC	XC		Not used	YC	Not used			
XD	Not used	YD		RFRP, RTOP instruction for interlock signal when A68ADN is used in remote I/O station	XD	Maximum value/minimum value reset completed flag		YD	Maximum value/minimum value reset request
XE		YE		XE	A/D conversion completed flag	YE		Not used	
XF		YF		XF	Error flag	YF		Error clear request	
X10	Not used	Y10	Not used						
X11		Y11		Not used					
X12		Y12		Error reset					
X13		Y13		Not used					
X14		Y14							
X15		Y15							
X16		Y16							
X17		Y17							
X18		Y18							
X19		Y19							
X1A		Y1A							
X1B		Y1B							
X1C		Y1C							
X1D		RFRP, RTOP instruction for interlock signal when A68ADN is used in remote I/O station		Y1D					
X1E		Y1E							
X1F		Y1F							

2.7.4 Buffer memory address comparison

Sequence program change is required as the assignment of buffer memory differs.

For details of the buffer memory or sequence program, refer to the Analog-Digital Converter Module User's Manual.

A68ADN			Q68ADV/I		
Address (Dec.)	Name	Read/write	Address (Dec.)	Name	Read/write
0	A/D conversion enable/disable setting	R/W	0	A/D conversion enable/disable	R/W
1	Averaging processing specification		1	CH1 Time/count averaging setting	
2	CH1 Averaging time, count		2	CH2 Time/count averaging setting	
3	CH2 Averaging time, count		3	CH3 Time/count averaging setting	
4	CH3 Averaging time, count		4	CH4 Time/count averaging setting	
5	CH4 Averaging time, count		5	CH5 Time/count averaging setting	
6	CH5 Averaging time, count		6	CH6 Time/count averaging setting	
7	CH6 Averaging time, count		7	CH7 Time/count averaging setting	
8	CH7 Averaging time, count		8	CH8 Time/count averaging setting	
9	CH8 Averaging time, count	R	9	Averaging processing specification	R
10	CH1 Digital output value		10	A/D conversion completed flag	
11	CH2 Digital output value		11	CH1 Digital output value	
12	CH3 Digital output value		12	CH2 Digital output value	
13	CH4 Digital output value		13	CH3 Digital output value	
14	CH5 Digital output value		14	CH4 Digital output value	
15	CH6 Digital output value		15	CH5 Digital output value	
16	CH7 Digital output value		16	CH6 Digital output value	
17	CH8 Digital output value		17	CH7 Digital output value	
18	Write data error code		18	CH8 Digital output value	
19	A/D conversion completed flag		19	Error code	
20	Resolution setting	R/W	20	Setting range (CH1 to CH4)	R/W
			21	Setting range (CH5 to CH8)	
			22	Offset/gain setting mode Offset specification	R/W
			23	Offset/gain setting mode Gain specification	
			24	System area (Not used)	-
			25		
			26		
			27		
			28		
			29		
			30	CH1 Maximum value	R
			31	CH1 Minimum value	
			32	CH2 Maximum value	
			33	CH2 Minimum value	
			34	CH3 Maximum value	
			35	CH3 Minimum value	
			36	CH4 Maximum value	
			37	CH4 Minimum value	
			38	CH5 Maximum value	
			39	CH5 Minimum value	
			40	CH6 Maximum value	
			41	CH6 Minimum value	
			42	CH7 Maximum value	
			43	CH7 Minimum value	
			44	CH8 Maximum value	
			45	CH8 Minimum value	

Q68ADV/I		
Address (Dec.)	Name	Read/write
46	System area (Not used)	-
to 157		
158	Mode switching setting	R/W
159		
160	System area (Not used)	-
to 201		
202		
202	CH1 Industrial shipment settings offset value	R/W
203	CH1 Industrial shipment settings gain value	
204	CH2 Industrial shipment settings offset value	
205	CH2 Industrial shipment settings gain value	
206	CH3 Industrial shipment settings offset value	
207	CH3 Industrial shipment settings gain value	
208	CH4 Industrial shipment settings offset value	
209	CH4 Industrial shipment settings gain value	
210	CH5 Industrial shipment settings offset value	
211	CH5 Industrial shipment settings gain value	
212	CH6 Industrial shipment settings offset value	
213	CH6 Industrial shipment settings gain value	
214	CH7 Industrial shipment settings offset value	
215	CH7 Industrial shipment settings gain value	
216	CH8 Industrial shipment settings offset value	
217	CH8 Industrial shipment settings gain value	
218	CH1 User range settings offset value	
219	CH1 User range settings gain value	
220	CH2 User range settings offset value	
221	CH2 User range settings gain value	
222	CH3 User range settings offset value	
223	CH3 User range settings gain value	
224	CH4 User range settings offset value	
225	CH4 User range settings gain value	
226	CH5 User range settings offset value	
227	CH5 User range settings gain value	
228	CH6 User range settings offset value	
229	CH6 User range settings gain value	
230	CH7 User range settings offset value	
231	CH7 User range settings gain value	
232	CH8 User range settings offset value	
233	CH8 User range settings gain value	

2.8 A68AD (Upgrade to Q68AD-G)

2.8.1 Performance comparison

Item		A68ADN																											
Analog input	Voltage	-10 to 0 to +10VDC (Input resistance value: 1MΩ)																											
	Current	-20 to 0 to +20mADC (Input resistance value: 250Ω)																											
Digital output		16-bit signed binary When 1/4000 is set: -4096 to +4095 When 1/8000 is set: -8192 to +8191 When 1/12000 is set: -12288 to +12287																											
I/O characteristics		<table border="1" style="margin-left: auto; margin-right: auto;"> <thead> <tr> <th rowspan="2">Analog input</th> <th colspan="3">Digital output value (When gain 5V/20mA, offset 0V/0mA)</th> </tr> <tr> <th>1/4000</th> <th>1/8000</th> <th>1/12000</th> </tr> </thead> <tbody> <tr> <td>+10V</td> <td>+4000</td> <td>+8000</td> <td>+12000</td> </tr> <tr> <td>+5V or +20mA</td> <td>+2000</td> <td>+4000</td> <td>+6000</td> </tr> <tr> <td>0V or 20mA</td> <td>0</td> <td>0</td> <td>0</td> </tr> <tr> <td>-5V or -20mA</td> <td>-2000</td> <td>-4000</td> <td>-6000</td> </tr> <tr> <td>-10V</td> <td>-4000</td> <td>-8000</td> <td>-12000</td> </tr> </tbody> </table> <p style="text-align: center;">(Factory-set: gain...5V, offset...0V)</p>	Analog input	Digital output value (When gain 5V/20mA, offset 0V/0mA)			1/4000	1/8000	1/12000	+10V	+4000	+8000	+12000	+5V or +20mA	+2000	+4000	+6000	0V or 20mA	0	0	0	-5V or -20mA	-2000	-4000	-6000	-10V	-4000	-8000	-12000
Analog input	Digital output value (When gain 5V/20mA, offset 0V/0mA)																												
	1/4000	1/8000	1/12000																										
+10V	+4000	+8000	+12000																										
+5V or +20mA	+2000	+4000	+6000																										
0V or 20mA	0	0	0																										
-5V or -20mA	-2000	-4000	-6000																										
-10V	-4000	-8000	-12000																										
Maximum resolution		<table border="1" style="margin-left: auto; margin-right: auto;"> <thead> <tr> <th></th> <th>1/4000</th> <th>1/8000</th> <th>1/12000</th> </tr> </thead> <tbody> <tr> <td>Voltage input</td> <td>2.5mV</td> <td>1.25mV</td> <td>0.83mV</td> </tr> <tr> <td>Current input</td> <td>10μA</td> <td>5μA</td> <td>3.33μA</td> </tr> </tbody> </table>		1/4000	1/8000	1/12000	Voltage input	2.5mV	1.25mV	0.83mV	Current input	10μA	5μA	3.33μA															
	1/4000	1/8000	1/12000																										
Voltage input	2.5mV	1.25mV	0.83mV																										
Current input	10μA	5μA	3.33μA																										
Overall accuracy (Accuracy in respect to maximum digital output value)		<table border="1" style="margin-left: auto; margin-right: auto;"> <thead> <tr> <th></th> <th>1/4000</th> <th>1/8000</th> <th>1/12000</th> </tr> </thead> <tbody> <tr> <td>±1%</td> <td>±40</td> <td>±80</td> <td>±120</td> </tr> </tbody> </table>		1/4000	1/8000	1/12000	±1%	±40	±80	±120																			
	1/4000	1/8000	1/12000																										
±1%	±40	±80	±120																										

○: Compatible, △: Partial change required, ×: Incompatible

Q68AD-G		Compatibility	Precautions for replacement																																																						
-10 to 10VDC (Input resistance value: 1MΩ or more)		○																																																							
0 to 20mADC (Input resistance value: 250Ω)																																																									
16-bit signed binary (Normal resolution mode: -4096 to 4095, High resolution mode: -12288 to 12287, -16384 to 16383)		○																																																							
Input	<table border="1"> <thead> <tr> <th rowspan="2">Analog input range</th> <th colspan="2">Normal resolution mode</th> <th colspan="2">High resolution mode</th> </tr> <tr> <th>Digital output value</th> <th>Maximum resolution</th> <th>Digital output value</th> <th>Maximum resolution</th> </tr> </thead> <tbody> <tr> <td>0 to 10V</td> <td rowspan="3">0 to 4000</td> <td>2.5mV</td> <td>0 to 16000</td> <td>0.625mV</td> </tr> <tr> <td>0 to 5V</td> <td>1.25mV</td> <td rowspan="2">0 to 12000</td> <td>0.416mV</td> </tr> <tr> <td>1 to 5V</td> <td>1.0mV</td> <td>0.333mV</td> </tr> <tr> <td>1 to 5V (Expanded mode)</td> <td>-1000 to 4500</td> <td>1.0mV</td> <td>-3000 to 13500</td> <td>0.333mV</td> </tr> <tr> <td>-10 to 10V</td> <td rowspan="2">-4000 to 4000</td> <td>2.5mV</td> <td>-16000 to 16000</td> <td>0.625mV</td> </tr> <tr> <td>Users range setting</td> <td>0.375mV</td> <td>-12000 to 12000</td> <td>0.333mV</td> </tr> <tr> <td rowspan="4">Current</td> <td>0 to 20mA</td> <td rowspan="2">0 to 4000</td> <td>5μA</td> <td rowspan="2">0 to 12000</td> <td>1.66μA</td> </tr> <tr> <td>4 to 20mA</td> <td>4μA</td> <td>1.33μA</td> </tr> <tr> <td>4 to 20mA (Expanded mode)</td> <td>-1000 to 4500</td> <td>4μA</td> <td>-3000 to 13500</td> <td>1.33μA</td> </tr> <tr> <td>Users range setting</td> <td>-4000 to 4000</td> <td>1.37μA</td> <td>-12000 to 12000</td> <td>1.33μA</td> </tr> </tbody> </table>	Analog input range	Normal resolution mode		High resolution mode		Digital output value	Maximum resolution	Digital output value	Maximum resolution	0 to 10V	0 to 4000	2.5mV	0 to 16000	0.625mV	0 to 5V	1.25mV	0 to 12000	0.416mV	1 to 5V	1.0mV	0.333mV	1 to 5V (Expanded mode)	-1000 to 4500	1.0mV	-3000 to 13500	0.333mV	-10 to 10V	-4000 to 4000	2.5mV	-16000 to 16000	0.625mV	Users range setting	0.375mV	-12000 to 12000	0.333mV	Current	0 to 20mA	0 to 4000	5μA	0 to 12000	1.66μA	4 to 20mA	4μA	1.33μA	4 to 20mA (Expanded mode)	-1000 to 4500	4μA	-3000 to 13500	1.33μA	Users range setting	-4000 to 4000	1.37μA	-12000 to 12000	1.33μA	△	As concept of gain value is changed, refer to Q68AD-G [User's Manual] and then, confirm the I/O characteristics.
Analog input range	Normal resolution mode		High resolution mode																																																						
	Digital output value	Maximum resolution	Digital output value	Maximum resolution																																																					
0 to 10V	0 to 4000	2.5mV	0 to 16000	0.625mV																																																					
0 to 5V		1.25mV	0 to 12000	0.416mV																																																					
1 to 5V		1.0mV		0.333mV																																																					
1 to 5V (Expanded mode)	-1000 to 4500	1.0mV	-3000 to 13500	0.333mV																																																					
-10 to 10V	-4000 to 4000	2.5mV	-16000 to 16000	0.625mV																																																					
Users range setting		0.375mV	-12000 to 12000	0.333mV																																																					
Current	0 to 20mA	0 to 4000	5μA	0 to 12000	1.66μA																																																				
	4 to 20mA		4μA		1.33μA																																																				
	4 to 20mA (Expanded mode)	-1000 to 4500	4μA	-3000 to 13500	1.33μA																																																				
	Users range setting	-4000 to 4000	1.37μA	-12000 to 12000	1.33μA																																																				
±0.1% Normal resolution mode: ±4 digits High resolution mode (0 to 10V, -10 to 10V): ±16 digits High resolution mode (Other than the above ranges): ±12 digits Temperature coefficient: ±71.4ppm/°C (0.00714%/°C)		○																																																							

Item	A68ADN	
Maximum conversion speed	20ms/channel	
Response time	-	
Absolute maximum input	Voltage: $\pm 15V$ Current: $\pm 30mA$	
Analog input points	8 channels/module	
Maximum number of writes for E ² PROM	-	
Isolation method	Between the input terminal and programmable controller power supply: photocoupler isolation Between channels: non-isolated	
Dielectric withstand voltage	Between the I/O terminal and programmable controller power supply: 500VAC, for 1 minute	
Insulation resistance	Between the I/O terminal and programmable controller power supply: 500VDC, 5M Ω or more	
Occupied I/O points	32 points (I/O assignment: special 32 points)	
Connected terminal	38-point terminal block	
Applicable wire size	0.75 to 2mm ² (Applicable tightening torque: 39 to 59N·cm)	
Applicable solderless terminal	V1.25-3, V1.25-YS3A, V2-S3, V2-YS3A	
Internal current consumption (5VDC)	0.4A	
Weight	0.51kg	

○ : Compatible, △ : Partial change required, × : Incompatible

	Q68AD-G	Compatibility	Precautions for replacement
	10ms/channel (Sampling cycle)	○	
	20ms		
	Voltage: ±15V current: ±30mA	○	
	8 channels/module	○	
	Up to 50,000 times	○	
	Between the I/O terminal and programmable controller power supply: transformer isolation Between channels: transformer isolation	○	
	Between the I/O terminal and programmable controller power supply: 500VACrms, for 1 minute Between analog input channels: 1000VACrms, for 1 minute	○	
	Between the I/O terminal and programmable controller power supply: 500VDC, 10MΩ or more Between analog input channels: 500VDC, 10MΩ or more	○	
	16 points (I/O assignment: intelligent 16 points)	△	I/O occupied points has changed to 16 points. Wiring change is required.
	40-pin connector	×	
	Within 0.3mm ²	×	
	-	×	
	0.46A	△	The recalculation of internal current consumption [5VDC] is required.
	0.16kg	○	

2.8.2 Function comparison

○ : With functions, - : Without functions

Item	Description	A68ADN	Q68AD-G	Precautions for replacement
A/D conversion enable/disable	Specifies whether to enable or disable the A/D conversion for each channel. By disabling the conversion for the channels that are not used, the sampling time can be shortened.	○	○	
Sampling processing	The A/D conversion for analog input values is performed successively for each channel, and the digital output value is output upon each conversion.	○	○	
Averaging processing	For each channel, A/D conversion values are averaged for the set number of times or set amount of time, and the average value is output as a digital value.	○	○	The setting range of average time and count differ. Refer to Q68AD-G [User's Manual] and then, confirm the specifications.
	Moving average takes the average of the specified number of digital output values measured per sampling time.	-	○	
Primary delay filter	A digital output value is smoothed according to the preset time constant.	-	○	
Maximum and minimum values hold function	The maximum and minimum values of the digital output values are retained in the module.	-	○	
Resolution mode	The resolution can be switched according to the application. The resolution mode is batch-set for all the channels.*1	○	○	
Input signal error detection function	The voltage/current outside the setting range is detected.	-	○	
Warning output function	(1) Process alarm A warning is output if a digital output value falls outside the setting range.	-	○	
	(2) Rate alarm A warning is output if the varying rate of a digital output value falls outside the preset varying rate range.			
Scaling function	Conversion of A/D conversion values to preset percentage values and loading into the buffer memory is available. Programming steps for the scaling can be eliminated.	-	○	
Online module change	A module change is made without the system being stopped.	-	○	Replaceable modules during online are a process CPU and a redundant CPU.

*1 For the A68ADN, the resolution for voltage and current can be set to 1/4000, 1/8000, 1/12000.
For the Q68AD-G, the resolution for voltage and current is 1/4000 in the normal resolution mode, while the resolution for the voltage from -10 to 10V is 1/16000 and the resolution for the voltage in other ranges and current is 1/12000 in the high resolution mode.

2.8.3 I/O signal comparison to programmable controller CPU

Sequence program change is required as the I/O signals differ.

For details of the I/O signals or sequence program, refer to the Channel Isolated Analog-Digital Converter Module, Channel Isolated Analog-Digital Converter Module (With Signal Conditioning Function) User's Manual.

A68ADN				Q68AD-G					
Device No.	Signal name	Device No.	Signal name	Device No.	Signal name	Device No.	Signal name		
X0	Watchdog timer error	Y0	Not used	X0	Module READY	Y0	Not used		
X1	A/D conversion READY	Y1		X1	Not used	Y1			
X2	Error flag	Y2		X2		Y2			
X3	Not used	Y3		X3		Y3			
X4		Y4		X4		Y4			
X5		Y5		X5		Y5			
X6		Y6		X6		Y6			
X7		Y7		X7	High resolution mode status flag	Y7			
X8		Y8		X8	Warming output signal	Y8			
X9	Not used	Y9		X9	Operating condition setting completed flag	Y9	Operating condition setting request		
XA		YA		XA	Offset/gain setting mode flag	YA	User range write request		
XB		YB		XB	Channel change completed flag	YB	Channel change request		
XC		YC		XC	Input signal error detection signal	YC	Not used		
XD		Not used		YD	RFRP, RTOP instruction for interlock signal when A68ADN is used in remote I/O station	XD	Maximum value/minimum value reset completed flag	YD	Maximum value/minimum value reset request
XE				YE	XE	A/D conversion completed flag	YE	Not used	
XF	YF			XF	Error flag	YF	Error clear request		
X10	Not used	Y10		Not used					
X11		Y11							
X12		Y12		Error reset					
X13		Y13	Not used						
X14		Y14							
X15		Y15							
X16		Y16							
X17		Y17							
X18		Y18							
X19		Y19							
X1A	Y1A								
X1B	Y1B								
X1C	Y1C								
X1D	RFRP, RTOP instruction for interlock signal when A68ADN is used in remote I/O station	Y1D							
X1E		Y1E							
X1F		Y1F							

2.8.4 Buffer memory address comparison

Sequence program change is required as the assignment of buffer memory differs.

For details of the I/O signals or sequence program, refer to the Channel Isolated Analog-Digital Converter Module, Channel Isolated Analog-Digital Converter Module (With Signal Conditioning Function) User's Manual.

A68ADN			Q68AD-G		
Address (Dec.)	Name	Read/write	Address (Dec.)	Name	Read/write
0	A/D conversion enable/disable setting	R/W	0	A/D conversion enable/disable	R/W
1	Averaging processing specification		1	CH1 Average time/Average number of times/ Moving average/Time constant settings	
2	CH1 Averaging time, count		2	CH2 Average time/Average number of times/ Moving average/Time constant settings	
3	CH2 Averaging time, count		3	CH3 Average time/Average number of times/ Moving average/Time constant settings	
4	CH3 Averaging time, count		4	CH4 Average time/Average number of times/ Moving average/Time constant settings	
5	CH4 Averaging time, count		5	CH5 Average time/Average number of times/ Moving average/Time constant settings	
6	CH5 Averaging time, count		6	CH6 Average time/Average number of times/ Moving average/Time constant settings	
7	CH6 Averaging time, count		7	CH7 Average time/Average number of times/ Moving average/Time constant settings	
8	CH7 Averaging time, count		8	CH8 Average time/Average number of times/ Moving average/Time constant settings	
9	CH8 Averaging time, count		9	System area (Not used)	
10	CH1 Digital output value	R	10	A/D conversion completed flag	R
11	CH2 Digital output value		11	CH1 Digital output value	
12	CH3 Digital output value		12	CH2 Digital output value	
13	CH4 Digital output value		13	CH3 Digital output value	
14	CH5 Digital output value		14	CH4 Digital output value	
15	CH6 Digital output value		15	CH5 Digital output value	
16	CH7 Digital output value		16	CH6 Digital output value	
17	CH8 Digital output value		17	CH7 Digital output value	
18	Write data error code		18	CH8 Digital output value	
19	A/D conversion completed flag	19	Error code		
20	Resolution setting	R/W	20	Setting range (CH1 to CH4)	
			21	Setting range (CH5 to CH8)	
			22	Offset/gain setting mode Offset specification	R/W
			23	Offset/gain setting mode Gain specification	
			24	Averaging process specification (CH1 to CH4)	
			25	Averaging process specification (CH5 to CH8)	
			26	System area (Not used)	-
			27		
			28		
			29		
			30	CH1 Maximum value	R
			31	CH1 Minimum value	
			32	CH2 Maximum value	
			33	CH2 Minimum value	
			34	CH3 Maximum value	
			to		
			44	CH8 Maximum value	
			45	CH8 Minimum value	

Q68AD-G		
Address (Dec.)	Name	Read/write
46	System area (Not used)	-
47	Input signal error detection extended/input signal error detection setting	R/W
48	Warning output setting	
49	Input signal error detection flag	R
50	Warning output flag (Process alarm)	
51	Warning output flag (Rate alarm)	-
52	System area (Not used)	
53	Scaling enable/disable setting	R/W
54	CH1 Scaling value	R
to		
61	CH8 Scaling value	R/W
62	CH1 Scaling lower limit value	
63	CH1 Scaling upper limit value	
to		
76	CH8 Scaling lower limit value	
77	CH8 Scaling upper limit value	
to		
86	CH1 Process alarm lower lower limit value	
87	CH1 Process alarm lower upper limit value	
88	CH1 Process alarm upper lower limit value	
89	CH1 Process alarm upper upper limit value	
to		
114	CH8 Process alarm lower lower limit value	
115	CH8 Process alarm lower upper limit value	
116	CH8 Process alarm upper lower limit value	
117	CH8 Process alarm upper upper limit value	
118	CH1 Rate alarm warning detection period	
to		
125	CH8 Rate alarm warning detection period	
126	CH1 Rate alarm upper limit value	
127	CH1 Rate alarm lower limit value	
to		
140	CH8 Rate alarm upper limit value	
141	CH8 Rate alarm lower limit value	
142	CH1 Input signal error detection setting value/CH1 Input signal error detection lower limit setting value	
to		
150	CH1 Input signal error detection upper limit setting value	
to		
158	Mode switching setting	R/W
159		
to		
200	Save data classification setting	R/W
201	System area (Not used)	-
202	CH1 Factory default offset value	R/W
203	CH1 Factory default gain value	
to		
232	CH8 Factory default offset value	
233	CH8 Factory default gain value	

3 ANALOG OUTPUT MODULE REPLACEMENT

3.1 List of Analog Output Module Alternative Models for Replacement

Production discontinuation		Transition to Q series	
Product	Model	Model	Remarks (Restrictions)
Analog output module	A616DAI	Q68DAIN	1) External wiring : Cable size is changed. 2) Number of slots : Changed (2 modules are required.) 3) Program : The number of occupied I/O points, I/O signals, and buffer memory addresses are changed. 4) Performance specifications change: 8CH/module 5) Functional specifications: Not changed
	A616DAV	Q68DAVN	1) External wiring : Cable size is changed. 2) Number of slots : Changed (2 modules are required.) 3) Program : The number of occupied I/O points, I/O signals, and buffer memory addresses are changed. 4) Performance specifications change: 8CH/module 5) Functional specifications: Not changed
	A62DA	Q62DAN	1) External wiring : Cable size is changed. 2) Number of slots : Not changed 3) Program : The number of occupied I/O points, I/O signals, and buffer memory addresses are changed. 4) Performance specifications change: Output current (minus current not applicable), I/O characteristics 5) Functional specifications: Not changed
		Q64DAN	1) External wiring : Cable size is changed. 2) Number of slots : Not changed 3) Program : The number of occupied I/O points, I/O signals, and buffer memory addresses are changed. 4) Performance specifications change: Output current (minus current not applicable), I/O characteristics 5) Functional specifications: Not changed
	A62DA-S1	Q62DAN	1) External wiring : Cable size is changed. 2) Number of slots : Not changed 3) Program : The number of occupied I/O points, I/O signals, and buffer memory addresses are changed. 4) Performance specifications change: Not changed 5) Functional specifications: Not changed
		Q64DAN	1) External wiring : Cable size is changed. 2) Number of slots : Not changed 3) Program : The number of occupied I/O points, I/O signals, and buffer memory addresses are changed. 4) Performance specifications change: 4CH/module 5) Functional specifications: Not changed
	A68DAI-S1	Q68DAIN	1) External wiring : Cable size is changed. 2) Number of slots : Not changed 3) Program : The number of occupied I/O points, I/O signals, and buffer memory addresses are changed. 4) Performance specifications change: Increase in current consumption 5) Functional specifications: Not changed

Production discontinuation		Transition to Q series	
Product	Model	Model	Remarks (Restrictions)
Analog output module	A68DAV	Q68DAVN	1) External wiring : Cable size is changed. 2) Number of slots: : Not changed 3) Program : The number of occupied I/O points, I/O signals, and buffer memory addresses are changed. 4) Performance specifications change: Increase in current consumption 5) Functional specifications: Not changed

☒ Point

The existing wiring for the A/QnA series modules can be connected directly to the Q series modules using the upgrade tool (conversion adaptor) manufactured by Mitsubishi Electric Engineering Co., Ltd.

(1) One slot type (can be mounted on the Q series large type base unit)

Product	MELSEC-A/QnA series module	MELSEC-Q series module	Conversion adaptor
Analog output module	A62DA	Q62DAN	ERNT-AQT62DA
	A62DA-S1		
	A68DAV	Q68DAVN	ERNT-AQT68DA
	A68DAI	Q68DAIN	
	A68DAI-S1		

(2) Two slot type
(cannot be mounted on the Q series large type base unit)

Product	MELSEC-A/QnA series module	MELSEC-Q series module	Conversion adaptor
Analog output module	A616DAV	Q68DAVN (×2 modules)	ERNT-AQT616DA
	A616DAI	Q68DAIN (×2 modules)	

For contact information for inquiries on the upgrade tool manufactured by Mitsubishi Electric Engineering Co., Ltd., refer to Section 2.1.

3.2 A616DAI

3.2.1 Performance comparison

Item	A616DAI									
Digital input	16-bit signed binary (Data part: 12 bits) Setting range: 0 to 4095									
Analog output	0 to 20mADC (External load resistance value: 0Ω to 600Ω)									
I/O characteristics	<table border="1"> <thead> <tr> <th>Digital input</th> <th>Analog output</th> </tr> </thead> <tbody> <tr> <td>+4000</td> <td>+20mA</td> </tr> <tr> <td>+2000</td> <td>+12mA</td> </tr> <tr> <td>0</td> <td>4mA</td> </tr> </tbody> </table>	Digital input	Analog output	+4000	+20mA	+2000	+12mA	0	4mA	
Digital input	Analog output									
+4000	+20mA									
+2000	+12mA									
0	4mA									
Digital value resolution	1/4000									
Overall accuracy (Accuracy at maximum analog output value)	0.6% (±120μA) When ambient temperature is 25°C: ±0.3% (±60μA)									
Sampling period	$1.5 + 0.5 \times (\text{D/A number of conversion enabled channels})$ ms									
Conversion time	0.5ms (Time required for conversion from 0 to 20mA/20mA to 0mA)									
Absolute maximum output	-									
No. of analog output channels	16 channels/module									
Number of writes to E ² PROM	-									
Output short protection	-									

○: Compatible, △: Partial change required, ×: Incompatible

		Q68DAIN				Compatibility	Precautions for replacement																								
		16-bit signed binary (Normal resolution mode: -4096 to 4095, High resolution mode: -12288 to 12287)				○																									
		0 to 20mADC (External load resistance value: 0Ω to 600Ω)				○																									
		<table border="1"> <thead> <tr> <th colspan="2" rowspan="2">Analog output range</th> <th colspan="2">Normal resolution mode</th> <th colspan="2">High resolution mode</th> </tr> <tr> <th>Digital input value</th> <th>Maximum resolution</th> <th>Digital input value</th> <th>Maximum resolution</th> </tr> </thead> <tbody> <tr> <td rowspan="3">Current</td> <td>0 to 20mA</td> <td rowspan="2">0 to 4000</td> <td>5μA</td> <td rowspan="2">0 to 12000</td> <td>1.66μA</td> </tr> <tr> <td>4 to 20mA</td> <td>4μA</td> <td>1.33μA</td> </tr> <tr> <td>User range settings</td> <td>-4000 to 4000</td> <td>1.5μA</td> <td>-12000 to 12000</td> <td>0.83μA</td> </tr> </tbody> </table>				Analog output range		Normal resolution mode		High resolution mode		Digital input value	Maximum resolution	Digital input value	Maximum resolution	Current	0 to 20mA	0 to 4000	5μA	0 to 12000	1.66μA	4 to 20mA	4μA	1.33μA	User range settings	-4000 to 4000	1.5μA	-12000 to 12000	0.83μA	○	
Analog output range		Normal resolution mode		High resolution mode																											
		Digital input value	Maximum resolution	Digital input value	Maximum resolution																										
Current	0 to 20mA	0 to 4000	5μA	0 to 12000	1.66μA																										
	4 to 20mA		4μA		1.33μA																										
	User range settings	-4000 to 4000	1.5μA	-12000 to 12000	0.83μA																										
		Ambient temperature 25±5°C: within ±0.1% (±20μA) Ambient temperature 0 to 55°C: within ±0.3% (±60μA)				○																									
		-				○																									
		80μs/channel				○																									
		21mA				○																									
		8 channels/module				△	Consider replacement with multiple Q68DAIN.																								
		Max. 100,000 times				○																									
		Available				○																									

Item		A616DAI	
Isolation method		Between the output terminal and programmable controller power supply: photocoupler isolation A616DAI channels: non-isolation	
Dielectric withstand voltage		-	
Insulation resistance		-	
Number of occupied I/O points		32 points (I/O assignment: special 32 points)	
Connected terminal		38-point terminal block	
Applicable wire size		0.75 to 2mm ²	
Applicable solderless terminal		V1.25-3, V1.25-YS3A, V2-S3, V2-YS3A	
Internal current consumption (5VDC)		0.3A	
External power supply	Voltage	+15VDC/-15VDC	
	Current consumption	+15VDC, 0.53A -15VDC, 0.125A	
	Inrush current	-	
Weight		0.69kg	

○ : Compatible, △ : Partial change required, × : Incompatible

	Q68DAIN	Compatibility	Precautions for replacement
	Between the I/O terminal and programmable controller power supply: photocoupler isolation Between output channels: non-isolation Between external power supply and analog output: transformer isolation	○	
	Between the I/O terminal and programmable controller power supply: 500VAC, for 1 minute	○	
	Between the I/O terminal and programmable controller power supply: 500VDC, 20MΩ or more	○	
	16 points (I/O assignment: intelligent 16 points)	△	The number of occupied I/O points has changed to 16 points.
	18-point terminal block	×	Wiring change is required.
	0.3 to 0.75mm ²	×	
	FG terminal: R1.25-3, 1.25-YS3, RAV1.25-3, V1.25-YS3A Terminals other than FG: R1.25-3 (Sleeved solderless terminal cannot be used.)	×	
	0.38A	△	The recalculation of internal current consumption (5VDC) is required.
	24VDC +20%, -15% Ripple, spike 500mV _{P-P} or less	×	As the external power supply has changed from ±15V to 24V, its change is required.
	0.27A		
	2.5A 230μs or less		
	0.20kg	○	

3.2.2 Functional comparison

○ : With functions, - : Without functions

Item	Description	A616DAI	Q68DAIN	Precautions for replacement																	
D/A conversion enable/disable function	Specifies whether to enable or disable the D/A conversion for each channel. By disabling the D/A conversion for the channels that are not used, the conversion speed can be shortened.	○	○																		
D/A output enable/disable function	Specifies whether to output the D/A conversion value or the offset value for each channel. The conversion speed stays constant regardless of whether D/A output is enabled or disabled.	○	○	On Q68DAIN, the output enable/disable is set with Y signal (CH□ Output enable/disable flag).																	
Synchronous output function	Obtains analog output synchronized with the programmable controller CPU. The analog output will be updated after Synchronous output request (YD) is set to ON and the time specified as "programmable controller CPU processing time + 120μs" has elapsed. However, the analog output will be fixed to CH1, and other channels (CH2 to CH8) cannot be used. When the module is mounted on a remote I/O station, the analog output will not be synchronized because of a link scan delay if the synchronous output function is specified.	-	○																		
Analog output HOLD/CLEAR function	Retains an analog value that was output when the programmable controller CPU is in the STOP status or an error occurs.	○	○	1) Refer to ("Analog output status combination list" in the Digital-Analog Converter Module User's Manual to check the execution status of output. 2) For the Q68DAIN, this function is set with the intelligent function module switch setting.																	
Analog output test while the programmable controller CPU is in the STOP status	Outputs the analog value converted from a digital value when CH□ Output enable/disable flag is forcibly turned on while the programmable controller CPU is in the STOP status. <table border="1" style="width: 100%; border-collapse: collapse;"> <thead> <tr> <th rowspan="2">Setting combination</th> <th>D/A conversion enable/disable</th> <th colspan="2">Enable</th> <th colspan="2">Disable</th> </tr> <tr> <th>CH□ Output enable/disable flag</th> <th>Enable</th> <th>Disable</th> <th>Enable</th> <th>Disable</th> </tr> </thead> <tbody> <tr> <td colspan="2">Analog output test</td> <td>Allowed</td> <td>Not allowed</td> <td colspan="2">Not allowed</td> </tr> </tbody> </table>	Setting combination	D/A conversion enable/disable	Enable		Disable		CH□ Output enable/disable flag	Enable	Disable	Enable	Disable	Analog output test		Allowed	Not allowed	Not allowed		-	○	
Setting combination	D/A conversion enable/disable		Enable		Disable																
	CH□ Output enable/disable flag	Enable	Disable	Enable	Disable																
Analog output test		Allowed	Not allowed	Not allowed																	
Resolution mode	Switches the resolution mode according to the application. The resolution can be selected from 1/4000 or 1/12000. The resolution mode is batch-set for all channels.	-	○																		
Online module replacement	Replaces a module without stopping the system.	-	○	Replaceable modules during online are the Process CPU and the Redundant CPU.																	

3.2.3 I/O signal comparison to programmable controller CPU

Sequence program change is required as the I/O signals differ.

For details of the I/O signals and sequence program, refer to the Digital-Analog Converter Module User's Manual.

A616DA1				Q68DAIN				
Device No.	Signal name	Device No.	Signal name	Device No.	Signal name	Device No.	Signal name	
X0	Watchdog timer error flag	Y0	Not used	X0	Module READY	Y0	Not used	
X1	D/A conversion READY flag	Y1		X1	Not used	Y1	CH1 Output enable/disable flag	
X2	Error flag	Y2		X2		Y2	CH2 Output enable/disable flag	
X3	Not used	Y3		X3		Y3	CH3 Output enable/disable flag	
X4		Y4		X4		Y4	CH4 Output enable/disable flag	
X5		Y5		X5		Y5	CH5 Output enable/disable flag	
X6		Y6		X6		Y6	CH6 Output enable/disable flag	
X7		Y7		X7		Y7	CH7 Output enable/disable flag	
X8		Y8		X8		High resolution mode status flag	Y8	CH8 Output enable/disable flag
X9		Y9		X9	Operating condition setting completion flag	Y9	Operating condition setting request	
XA		YA		XA	Offset/gain setting mode status flag	YA	User range write request	
XB		YB		XB	Channel change completion flag	YB	Channel change request	
XC		YC		XC	Setting value change completion flag	YC	Setting value change request	
XD	YD	XD		RFRP, RTOP instruction interlock signal	XD	Synchronous output mode flag	YD	Synchronous output request
XE	YE	XE		Not used	XE	Not used	YE	Not used
XF	YF	XF			Error flag	YF	Error clear request	
X10	Not used	Y10		Not used				
X11		Y11						
X12		Y12						
X13		Y13						
X14		Y14						
X15		Y15						
X16		Y16						
X17		Y17						
X18		Y18						
X19		Y19						
X1A	Y1A							
X1B	Y1B	Y1B	Output enable batch flag					
X1C	Y1C							
X1D	RFRP, RTOP instruction interlock signal	Y1D	Not used					
X1E	Y1E							
X1F	Y1F							

3.2.4 Buffer memory address comparison

Sequence program change is required as the assignment of buffer memories differs.

For details of the buffer memories and sequence program, refer to the Digital-Analog Converter Module User's Manual.

A616DAI			Q68DAIN		
Address (decimal)	Name	Read/write	Address (decimal)	Name	Read/write
0	D/A conversion enable/disable channel	R/W	0	D/A conversion enable/disable	R/W
1	Analog output enable/disable channel		1	CH1 Digital value	
2	System area (Not used)	-	2	CH2 Digital value	
3			3	CH3 Digital value	
4			4	CH4 Digital value	
5			5	CH5 Digital value	
6			6	CH6 Digital value	
7			7	CH7 Digital value	
8			8	CH8 Digital value	
9			9	System area (Not used)	-
10	System area (Not used)	-	10	System area (Not used)	
11			11	CH1 Setting value check code	
12			12	CH2 Setting value check code	
13			13	CH3 Setting value check code	
14			14	CH4 Setting value check code	
15			15	CH5 Setting value check code	
16			16	CH6 Setting value check code	
17			17	CH7 Setting value check code	
18	18	CH8 Setting value check code			
19	19	Error code	R		
20	20	Setting range (CH1 to CH4)			
21	21	Setting range (CH5 to CH8)			
22	22	Offset/gain setting mode Offset specification	R/W		
23	23	Offset/gain setting mode Gain specification			
24	24	Offset/gain adjusted value specification			
25	System area (Not used)	-	25	System area (Not used)	
26			26		
27			27		
28			28		
29			29		
30			30		
31			31		
32			32		
to	to	-	to		
47	47		47		

A616DAI			Q68DAIN		
Address (decimal)	Name	Read/write	Address (decimal)	Name	Read/write
48	CH0 Setting value check code	R/W	48	System area (Not used)	-
49	CH1 Setting value check code				
50	CH2 Setting value check code				
51	CH3 Setting value check code				
52	CH4 Setting value check code				
53	CH5 Setting value check code				
54	CH6 Setting value check code				
55	CH7 Setting value check code				
56	CH8 Setting value check code				
57	CH9 Setting value check code				
58	CHA Setting value check code				
59	CHB Setting value check code				
60	CHC Setting value check code				
61	CHD Setting value check code				
62	CHE Setting value check code				
63	CHF Setting value check code				
			to		
			157		
			158	Mode switching setting	R/W
			159		
			160		
			to	System area (Not used)	-
			201		
			202	CH1 Industrial shipment settings offset value	R/W
			203	CH1 Industrial shipment settings gain value	
			204	CH2 Industrial shipment settings offset value	
			205	CH2 Industrial shipment settings gain value	
			206	CH3 Industrial shipment settings offset value	
			207	CH3 Industrial shipment settings gain value	
			208	CH4 Industrial shipment settings offset value	
			209	CH4 Industrial shipment settings gain value	
			210	CH5 Industrial shipment settings offset value	
			211	CH5 Industrial shipment settings gain value	
			212	CH6 Industrial shipment settings offset value	
			213	CH6 Industrial shipment settings gain value	
			214	CH7 Industrial shipment settings offset value	
			215	CH7 Industrial shipment settings gain value	
			216	CH8 Industrial shipment settings offset value	
			217	CH8 Industrial shipment settings gain value	
			218	CH1 User range settings offset value	
			219	CH1 User range settings gain value	
			220	CH2 User range settings offset value	
			221	CH2 User range settings gain value	
			222	CH3 User range settings offset value	
			223	CH3 User range settings gain value	
			224	CH4 User range settings offset value	
			225	CH4 User range settings gain value	
			226	CH5 User range settings offset value	
			227	CH5 User range settings gain value	
			228	CH6 User range settings offset value	
			229	CH6 User range settings gain value	
			230	CH7 User range settings offset value	
			231	CH7 User range settings gain value	
			232	CH8 User range settings offset value	
			233	CH8 User range settings gain value	

3.3 A616DAV

3.3.1 Performance comparison

Item	A616DAV																						
Digital input	16-bit signed binary (Data part: 12 bits) Setting range: -4096 to 4095																						
Analog output	When output voltage range setting is 10V: -10V to 0V to +10V (External load resistance value: 2kΩ to 1MΩ) When output voltage range setting is 5V: -5V to 0V to +5V (External load resistance value: 2kΩ to 1MΩ)																						
I/O characteristics	<table border="1"> <thead> <tr> <th rowspan="2">Digital input</th> <th colspan="2">Analog output</th> </tr> <tr> <th>5V setting</th> <th>10V setting</th> </tr> </thead> <tbody> <tr> <td>+4000</td> <td>+5V</td> <td>+10V</td> </tr> <tr> <td>+2000</td> <td>+2.5V</td> <td>+5V</td> </tr> <tr> <td>0</td> <td>0V</td> <td>0V</td> </tr> <tr> <td>-2000</td> <td>-2.5V</td> <td>-5V</td> </tr> <tr> <td>-4000</td> <td>-5V</td> <td>-10V</td> </tr> </tbody> </table>			Digital input	Analog output		5V setting	10V setting	+4000	+5V	+10V	+2000	+2.5V	+5V	0	0V	0V	-2000	-2.5V	-5V	-4000	-5V	-10V
Digital input	Analog output																						
	5V setting	10V setting																					
+4000	+5V	+10V																					
+2000	+2.5V	+5V																					
0	0V	0V																					
-2000	-2.5V	-5V																					
-4000	-5V	-10V																					
Digital value resolution	1/4000																						
Overall accuracy (accuracy at maximum analog output value)	Output voltage range setting	10V	5V																				
	Ambient temperature (0 to 55°C)	±0.6% (±60mV)	±0.6% (±30mV)																				
	Ambient temperature (25°C)	±0.3% (±30mV)	±0.3% (±15mV)																				
Sampling period	1.5 + 0.5 × (D/A number of conversion enabled channels) ms																						
Conversion time	0.5ms (Time required for conversion from -10 to +10V/+10 to -10V)																						
Absolute maximum output	15V																						
No. of analog output channels	16 channels/module																						
Number of writes to E ² PROM	-																						
Output short protection	-																						
Isolation method	Between the output terminal and programmable controller power supply: photocoupler isolation A616DAV channels: non-isolation																						
Dielectric withstand voltage	-																						
Insulation resistance	-																						
Number of occupied I/O points	32 points (I/O assignment: special 32 points)																						
Connected terminal	38-point terminal block																						
Applicable wire size	0.75 to 2mm ²																						
Applicable solderless terminal	V1.25-3, V1.25-YS3A, V2-S3, V2-YS3A																						
Internal current consumption (5VDC)	0.38A																						

○: Compatible, △: Partial change required, ×: Incompatible

		Q68DAVN				Compatibility	Precautions for replacement																												
		16-bit signed binary (Normal resolution mode: -4096 to 4095, High resolution mode: -12288 to 12287, -16384 to 16383)				○																													
		-10 to 10VDC (External load resistance value: 1kΩ to 1MΩ)				○																													
		<table border="1"> <thead> <tr> <th colspan="2" rowspan="2">Analog output range</th> <th colspan="2">Normal resolution mode</th> <th colspan="2">High resolution mode</th> </tr> <tr> <th>Digital input value</th> <th>Maximum resolution</th> <th>Digital input value</th> <th>Maximum resolution</th> </tr> </thead> <tbody> <tr> <td rowspan="4">Voltage</td> <td>0 to 5V</td> <td rowspan="2">0 to 4000</td> <td>1.25mV</td> <td rowspan="2">0 to 12000</td> <td>0.416mV</td> </tr> <tr> <td>1 to 5V</td> <td>1.0mV</td> <td>0.333mV</td> </tr> <tr> <td>-10 to 10V</td> <td rowspan="2">-4000 to 4000</td> <td>2.5mV</td> <td>-16000 to 16000</td> <td>0.625mV</td> </tr> <tr> <td>User range settings</td> <td>0.75mV</td> <td>-12000 to 12000</td> <td>0.333mV</td> </tr> </tbody> </table>				Analog output range		Normal resolution mode		High resolution mode		Digital input value	Maximum resolution	Digital input value	Maximum resolution	Voltage	0 to 5V	0 to 4000	1.25mV	0 to 12000	0.416mV	1 to 5V	1.0mV	0.333mV	-10 to 10V	-4000 to 4000	2.5mV	-16000 to 16000	0.625mV	User range settings	0.75mV	-12000 to 12000	0.333mV	○	When using A616DAVN in [-5 to + 5V] range, Q68DAVN can obtain equivalent resolution or more than A616DAV by setting in [-10 to 10V] range/ high resolution mode or user range.
Analog output range		Normal resolution mode		High resolution mode																															
		Digital input value	Maximum resolution	Digital input value	Maximum resolution																														
Voltage	0 to 5V	0 to 4000	1.25mV	0 to 12000	0.416mV																														
	1 to 5V		1.0mV		0.333mV																														
	-10 to 10V	-4000 to 4000	2.5mV	-16000 to 16000	0.625mV																														
	User range settings		0.75mV	-12000 to 12000	0.333mV																														
		Ambient temperature 25±5°C: Within ±0.1% (±10mV) Ambient temperature 0 to 55°C: Within ±0.3% (±30mV)				○																													
		-				○																													
		80μs/channel				○																													
		±12V				○																													
		8 channels/module				△	Consider replacement with multiple Q68DAVN.																												
		Max. 100,000 times				○																													
		Available				○																													
		Between the I/O terminal and programmable controller power supply: photocoupler isolation Between output channels: non-isolation Between external power supply and analog output: transformer isolation				○																													
		Between the I/O terminal and programmable controller power supply: 500VAC, for 1 minute				○																													
		Between the I/O terminal and programmable controller power supply: 500VDC, 20MΩ or more				○																													
		16 points (I/O assignment: intelligent 16 points)				△	The number of occupied I/O points has changed to 16 points.																												
		18-point terminal block				×																													
		0.3 to 0.75mm ²				×	Wiring change is required.																												
		FG terminal: R1.25-3, 1.25-YS3, RAV1.25-3, V1.25-YS3A Terminals other than FG: R1.25-3 (Sleeved solderless terminal cannot be used.)				×																													
		0.38A				○																													

Item		A616DAV	
External power supply	Voltage	+15VDC / -15VDC	
	Current consumption	+15VDC, 0.2A -15VDC, 0.17A	
	Inrush current	-	
Weight		0.65kg	

○ : Compatible, △ : Partial change required, × : Incompatible

	Q68DAVN	Compatibility	Precautions for replacement
	24VDC +20%, -15% Ripple, spike 500mV _{P-P} or less	×	As the external power supply has changed from ±15V to 24V, its change is required.
	0.20A		
	2.5A, 230μs or less		
	0.20kg	○	

3.3.2 Functional comparison

○ : With functions, - : Without functions

Item	Description	A616DAV	Q68DAVN	Precautions for replacement																	
D/A conversion enable/disable function	Specifies whether to enable or disable the D/A conversion for each channel. By disabling the D/A conversion for the channels that are not used, the conversion speed can be shortened.	○	○																		
D/A output enable/disable function	Specifies whether to output the D/A conversion value or the offset value for each channel. The conversion speed stays constant regardless of whether D/A output is enabled or disabled.	○	○	On Q68DAVN, the output enable/disable is set with Y signal (CH□ Output enable/disable flag).																	
Synchronous output function	Obtains analog output synchronized with the programmable controller CPU. The analog output will be updated after Synchronous output request (YD) is set to ON and the time specified as "programmable controller CPU processing time + 120μs" has elapsed. However, the analog output will be fixed to CH1, and other channels (CH2 to CH8) cannot be used. When the module is mounted on a remote I/O station, the analog output will not be synchronized because of a link scan delay if the synchronous output function is specified.	-	○																		
Analog output HOLD/CLEAR function	Retains an analog value that was output when the programmable controller CPU is in the STOP status or an error occurs.	○	○	1) Refer to ("Analog output status combination list" in the Digital-Analog Converter Module User's Manual to check the execution status of output. 2) For the Q68DAVN, this function is set with the intelligent function module switch setting.																	
Analog output test while the programmable controller CPU is in the STOP status	Outputs the analog value converted from a digital value when CH□ Output enable/disable flag is forcibly turned on while the programmable controller CPU is in the STOP status. <table border="1" data-bbox="347 1451 900 1624"> <thead> <tr> <th rowspan="2">Setting combination</th> <th>D/A conversion enable/disable</th> <th colspan="2">Enable</th> <th colspan="2">Disable</th> </tr> <tr> <th>CH□ Output enable/disable flag</th> <th>Enable</th> <th>Disable</th> <th>Enable</th> <th>Disable</th> </tr> </thead> <tbody> <tr> <td>Analog output test</td> <td>Allowed</td> <td>Not allowed</td> <td colspan="3">Not allowed</td> </tr> </tbody> </table>	Setting combination	D/A conversion enable/disable	Enable		Disable		CH□ Output enable/disable flag	Enable	Disable	Enable	Disable	Analog output test	Allowed	Not allowed	Not allowed			-	○	
Setting combination	D/A conversion enable/disable		Enable		Disable																
	CH□ Output enable/disable flag	Enable	Disable	Enable	Disable																
Analog output test	Allowed	Not allowed	Not allowed																		
Resolution mode	Switches the resolution mode according to the application. The resolution can be selected from 1/4000, 1/12000, or 1/16000. The resolution mode is batch-set for all channels.	-	○																		
Online module replacement	Replaces a module without stopping the system.	-	○	Replaceable modules during online are the Process CPU and the Redundant CPU.																	

3.3.3 I/O signal comparison to programmable controller CPU

Sequence program change is required as the I/O signals differ.

For details of the I/O signals and sequence program, refer to the Digital-Analog Converter Module User's Manual.

A616DAV				Q68DAVN				
Device No.	Signal name	Device No.	Signal name	Device No.	Signal name	Device No.	Signal name	
X0	Watchdog timer error flag	Y0	Not used	X0	Module READY	Y0	Not used	
X1	D/A conversion READY flag	Y1		X1	Not used	Y1	CH1 Output enable/disable flag	
X2	Error flag	Y2		X2		Y2	CH2 Output enable/disable flag	
X3	Not used	Y3		X3		Y3	CH3 Output enable/disable flag	
X4		Y4		X4		Y4	CH4 Output enable/disable flag	
X5		Y5		X5		Y5	CH5 Output enable/disable flag	
X6		Y6		X6		Y6	CH6 Output enable/disable flag	
X7		Y7		X7		Y7	CH7 Output enable/disable flag	
X8		Y8		X8		High resolution mode status flag	Y8	CH8 Output enable/disable flag
X9		Y9		X9	Operating condition setting completion flag	Y9	Operating condition setting request	
XA		YA		XA	Offset/gain setting mode status flag	YA	User range write request	
XB		YB		XB	Channel change completion flag	YB	Channel change request	
XC		YC		XC	Setting value change completion flag	YC	Setting value change request	
XD	YD	XD		RFRP, RTOP instruction interlock signal	XD	Synchronous output mode flag	YD	Synchronous output request
XE	YE	XE		Not used	XE	Not used	YE	Not used
XF	YF	XF			YF	Error flag	YF	Error clear request
X10	Y10	Not used			Not used			
X11	Y11							
X12	Y12							
X13	Y13							
X14	Y14							
X15	Y15							
X16	Y16							
X17	Y17							
X18	Y18							
X19	Y19							
X1A	Y1A	Output enable batch flag						
X1B	Y1B							
X1C	Y1C							
X1D	Y1D	Not used						
X1E	Y1E							
X1F	Y1F							
X1D	RFRP, RTOP instruction interlock signal		Y1D					

3.3.4 Buffer memory address comparison

Sequence program change is required as the assignment of buffer memories differs.

For details of the buffer memories and sequence program, refer to the Digital-Analog Converter Module User's Manual.

A616DAV			Q68DAVN		
Address (decimal)	Name	Read/write	Address (decimal)	Name	Read/write
0	D/A conversion enable/disable channel	R/W	0	D/A conversion enable/disable	R/W
1	Analog output enable/disable channel		1	CH1 Digital value	
2	System area (Not used)	-	2	CH2 Digital value	
3			3	CH3 Digital value	
4			4	CH4 Digital value	
5			5	CH5 Digital value	
6			6	CH6 Digital value	
7			7	CH7 Digital value	
8			8	CH8 Digital value	
9			9	System area (Not used)	-
10	10	R	11	CH1 Setting value check code	
11	11		12	CH2 Setting value check code	
12	12		13	CH3 Setting value check code	
13	13		14	CH4 Setting value check code	
14	14		15	CH5 Setting value check code	
15	15		16	CH6 Setting value check code	
16	CH0 Digital value		16	CH7 Setting value check code	
17	CH1 Digital value		17	CH8 Setting value check code	
18	CH2 Digital value	R/W	18	Error code	
19	CH3 Digital value		19	Setting range (CH1 to CH4)	
20	CH4 Digital value		20	Setting range (CH5 to CH8)	
21	CH5 Digital value		21	Offset/gain setting mode Offset specification	
22	CH6 Digital value		22	Offset/gain setting mode Gain specification	
23	CH7 Digital value		23	Offset/gain adjusted value specification	
24	CH8 Digital value		-	24	System area (Not used)
25	CH9 Digital value			25	
26	CHA Digital value	26			
27	CHB Digital value	27			
28	CHC Digital value	28			
29	CHD Digital value	29			
30	CHE Digital value	30			
31	CHF Digital value	31			
32	System area (Not used)	-	32	-	
to			to		
47			47		

A616DAV			Q68DAVN		
Address (decimal)	Name	Read/write	Address (decimal)	Name	Read/write
48	CH0 Setting value check code	R/W	48	System area (Not used)	-
49	CH1 Setting value check code				
50	CH2 Setting value check code				
51	CH3 Setting value check code				
52	CH4 Setting value check code				
53	CH5 Setting value check code				
54	CH6 Setting value check code				
55	CH7 Setting value check code				
56	CH8 Setting value check code				
57	CH9 Setting value check code				
58	CHA Setting value check code				
59	CHB Setting value check code				
60	CHC Setting value check code				
61	CHD Setting value check code				
62	CHE Setting value check code				
63	CHF Setting value check code				
			to		
			157		
			158	Mode switching setting	R/W
			159		
			160		
			to	System area (Not used)	-
			201		
			202	CH1 Industrial shipment settings offset value	R/W
			203	CH1 Industrial shipment settings gain value	
			204	CH2 Industrial shipment settings offset value	
			205	CH2 Industrial shipment settings gain value	
			206	CH3 Industrial shipment settings offset value	
			207	CH3 Industrial shipment settings gain value	
			208	CH4 Industrial shipment settings offset value	
			209	CH4 Industrial shipment settings gain value	
			210	CH5 Industrial shipment settings offset value	
			211	CH5 Industrial shipment settings gain value	
			212	CH6 Industrial shipment settings offset value	
			213	CH6 Industrial shipment settings gain value	
			214	CH7 Industrial shipment settings offset value	
			215	CH7 Industrial shipment settings gain value	
			216	CH8 Industrial shipment settings offset value	
			217	CH8 Industrial shipment settings gain value	
			218	CH1 User range settings offset value	
			219	CH1 User range settings gain value	
			220	CH2 User range settings offset value	
			221	CH2 User range settings gain value	
			222	CH3 User range settings offset value	
			223	CH3 User range settings gain value	
			224	CH4 User range settings offset value	
			225	CH4 User range settings gain value	
			226	CH5 User range settings offset value	
			227	CH5 User range settings gain value	
			228	CH6 User range settings offset value	
			229	CH6 User range settings gain value	
			230	CH7 User range settings offset value	
			231	CH7 User range settings gain value	
			232	CH8 User range settings offset value	
			233	CH8 User range settings gain value	

3.4 A62DA (Replacement to the Q62DAN)

3.4.1 Performance comparison

Item	A62DA																				
Digital input	Maximum setting value Voltage: ± 2000 Current: ± 1000																				
Analog output	Voltage: -10 to 0 to +10VDC (External load resistance value: 500Ω to $1M\Omega$) Current: +4 to +20mADC (External load resistance value: 0Ω to 600Ω) *Current output is usable by -20 to +20mA.																				
I/O characteristics	<table border="1"> <thead> <tr> <th rowspan="2">Digital input</th> <th colspan="2">Analog output</th> </tr> <tr> <th>Voltage</th> <th>Current</th> </tr> </thead> <tbody> <tr> <td>+2000</td> <td>+10V</td> <td>-</td> </tr> <tr> <td>+1000</td> <td>+5V</td> <td>+20mA</td> </tr> <tr> <td>0</td> <td>0V</td> <td>+4mA</td> </tr> <tr> <td>-1000</td> <td>-5V</td> <td>-12mA</td> </tr> <tr> <td>-2000</td> <td>-10V</td> <td>-</td> </tr> </tbody> </table>	Digital input	Analog output		Voltage	Current	+2000	+10V	-	+1000	+5V	+20mA	0	0V	+4mA	-1000	-5V	-12mA	-2000	-10V	-
Digital input	Analog output																				
	Voltage	Current																			
+2000	+10V	-																			
+1000	+5V	+20mA																			
0	0V	+4mA																			
-1000	-5V	-12mA																			
-2000	-10V	-																			
Maximum resolution	Voltage: 5mV (1/2000) Current: 20 μ A (1/1000)																				
Overall accuracy (accuracy at maximum analog output value)	$\pm 1\%$ (voltage: $\pm 0.1V$, current: $\pm 0.2mA$)																				
Maximum conversion speed	Within 15ms/2 channels (same time for one channel) Note) Time from when the digital input is written to when the specified analog voltage (current) is reached																				
Absolute maximum output	Voltage: $\pm 12V$ Current: $\pm 28mA$ Note) Max. output voltage and current restricted by output protection circuit																				
Number of analog output points	2 channels/module																				
Number of writes to E ² PROM	-																				
Output short protection	-																				

○: Compatible, △: Partial change required, ×: Incompatible

Q62DAN		Compatibility	Precautions for replacement																																									
16-bit signed binary Normal resolution mode: -4096 to 4095 High resolution mode: -12288 to 12287, -16384 to 16383		△	According to the I/O conversion characteristics used, make the output range setting and offset/gain setting of the Q62DAN.																																									
Voltage: -10 to 10VDC (External load resistance value: 1kΩ to 1MΩ) Current: 0 to 20mADC (External load resistance value: 0Ω to 600Ω)		○	The minus current cannot be output.																																									
<table border="1"> <thead> <tr> <th rowspan="2">Analog output range</th> <th colspan="2">Normal resolution mode</th> <th colspan="2">High resolution mode</th> </tr> <tr> <th>Digital input value</th> <th>Maximum resolution</th> <th>Digital input value</th> <th>Maximum resolution</th> </tr> </thead> <tbody> <tr> <td rowspan="4">Voltage</td> <td>0 to 5V</td> <td rowspan="2">0 to 4000</td> <td>1.25mV</td> <td rowspan="2">0 to 12000</td> <td>0.416mV</td> </tr> <tr> <td>1 to 5V</td> <td>1.0mV</td> <td>0.333mV</td> </tr> <tr> <td>-10 to 10V</td> <td rowspan="2">-4000 to 4000</td> <td>2.5mV</td> <td>-16000 to 16000</td> <td>0.625mV</td> </tr> <tr> <td>User range settings</td> <td>0.75mV</td> <td>-12000 to 12000</td> <td>0.333mV</td> </tr> <tr> <td rowspan="3">Current</td> <td>0 to 20mA</td> <td rowspan="2">0 to 4000</td> <td>5 μA</td> <td rowspan="2">0 to 12000</td> <td>1.66 μA</td> </tr> <tr> <td>4 to 20mA</td> <td>4 μA</td> <td>1.33 μA</td> </tr> <tr> <td>User range settings</td> <td>-4000 to 4000</td> <td>1.5 μA</td> <td>-12000 to 12000</td> <td>0.83 μA</td> </tr> </tbody> </table>		Analog output range	Normal resolution mode		High resolution mode		Digital input value	Maximum resolution	Digital input value	Maximum resolution	Voltage	0 to 5V	0 to 4000	1.25mV	0 to 12000	0.416mV	1 to 5V	1.0mV	0.333mV	-10 to 10V	-4000 to 4000	2.5mV	-16000 to 16000	0.625mV	User range settings	0.75mV	-12000 to 12000	0.333mV	Current	0 to 20mA	0 to 4000	5 μA	0 to 12000	1.66 μA	4 to 20mA	4 μA	1.33 μA	User range settings	-4000 to 4000	1.5 μA	-12000 to 12000	0.83 μA	△	According to the I/O conversion characteristics used, make the output range setting and offset/gain setting of the Q62DAN.
Analog output range	Normal resolution mode		High resolution mode																																									
	Digital input value	Maximum resolution	Digital input value	Maximum resolution																																								
Voltage	0 to 5V	0 to 4000	1.25mV	0 to 12000	0.416mV																																							
	1 to 5V		1.0mV		0.333mV																																							
	-10 to 10V	-4000 to 4000	2.5mV	-16000 to 16000	0.625mV																																							
	User range settings		0.75mV	-12000 to 12000	0.333mV																																							
Current	0 to 20mA	0 to 4000	5 μA	0 to 12000	1.66 μA																																							
	4 to 20mA		4 μA		1.33 μA																																							
	User range settings	-4000 to 4000	1.5 μA	-12000 to 12000	0.83 μA																																							
Ambient temperature 25±5°C: within ±0.1% (voltage: ±10mV, current: ±20μA) Ambient temperature 0 to 55°C: within ±0.3% (voltage: ±30mV, current: ±60μA)		○																																										
80μs/channel		○																																										
Voltage: ±12V Current: 21mA		△	The minus current cannot be output.																																									
2 channels/module		○																																										
Max. 100,000 times		○																																										
Available		○																																										

Item		A62DA
Isolation method		Between the output terminal and programmable controller power supply: photocoupler isolation (Between channels: non-isolation)
Dielectric withstand voltage		-
Insulation resistance		-
Number of occupied I/O points		32 points (I/O assignment: special 32 points)
Connected terminal		20-point terminal block
Applicable wire size		0.75 to 2mm ² (Applicable tightening torque: 39 to 59N•cm)
Applicable solderless terminal		V1.25-3, V1.25-YS3A, V2-S3, V2-YS3A
Internal current consumption (5VDC)		0.6A
External power supply	Voltage	21.6 to 26.4VDC
	Current consumption	0.35A
	Inrush current	2.4A
Weight		0.5kg

○ : Compatible, △ : Partial change required, × : Incompatible

	Q62DAN	Compatibility	Precautions for replacement
	Between the I/O terminal and programmable controller power supply: photocoupler isolation Between output channels: non-isolation Between external power supply and analog output: transformer isolation	○	
	Between the I/O terminal and programmable controller power supply: 500VAC, for 1 minute	○	
	Between the I/O terminal and programmable controller power supply: 500VDC, 20MΩ or more	○	
	16 points (I/O assignment: intelligent 16 points)	△	The number of occupied I/O points has changed to 16 points.
	18-point terminal block	×	Wiring change is required.
	0.3 to 0.75mm ²	×	
	R1.25-3 (Sleeved solderless terminal cannot be used.)	×	
	0.33A	○	
	24VDC +20%, -15% Ripple, spike 500mV _{P-P} or less	○	
	0.15A	○	
	2.5A, 250μs or less	○	
	0.19kg	○	

3.4.2 Functional comparison

○ : Available, - : Not available

Item	Description	A62DA	Q62DAN	Precautions for replacement
Analog output HOLD/CLEAR function	Retains an analog value that was output when the programmable controller CPU is in the STOP status or an error occurs.	-	○	
D/A conversion enable/disable function	Specifies whether to enable or disable the D/A conversion.	-	○	
D/A output enable/disable function	Specifies whether to output the D/A conversion value or the offset value.	○	○	The Q62DAN specifies whether to enable or disable output for each channel.
Synchronous output function	Obtains analog output synchronized with the programmable controller CPU.	-	○	
Analog output test while the programmable controller CPU is in the STOP status	Outputs the analog value converted from a digital value when CH□ Output enable/disable flag is forcibly turned on while the programmable controller CPU is in the STOP status.	-	○	
Resolution mode	Switches the resolution mode according to the application. The resolution can be selected from 1/4000, 1/12000, or 1/16000. The resolution mode is batch-set for all channels.	-	○	
Online module replacement	Replaces a module without stopping the system.	-	○	Replaceable modules during online are the Process CPU and the Redundant CPU.

3.4.3 I/O signal comparison to programmable controller CPU

Sequence program change is required as the I/O signals differ.

For details of the I/O signals and sequence program, refer to the Digital-Analog Converter Module User's Manual.

A62DA				Q62DAN			
Device No.	Signal name	Device No.	Signal name	Device No.	Signal name	Device No.	Signal name
X0	Watchdog timer error	Y0	Not used	X0	Module READY	Y0	Not used
X1	D/A conversion READY	Y1		X1	Not used	Y1	CH1 Output enable/disable flag
X2	Not used	Y2		X2		Y2	CH2 Output enable/disable flag
X3		Y3		X3		Y3	Not used
X4		Y4		X4		Y4	
X5		Y5		X5		Y5	
X6		Y6		X6		Y6	
X7		Y7		X7		Y7	
X8		Y8		X8	High resolution mode status flag	Y8	
X9		Y9		X9	Operating condition setting completion flag	Y9	Operating condition setting request
XA		YA		XA	Offset/gain setting mode status flag	YA	User range write request
XB		YB		XB	Channel change completion flag	YB	Channel change request
XC		YC		XC	Setting value change completion flag	YC	Setting value change request
XD		YD		XD	Synchronous output mode flag	YD	Synchronous output request
XE		YE		XE	Not used	YE	Not used
XF		YF		XF	Error flag	YF	Error clear request
X10		Y10					
X11		Y11					
X12		Y12					
X13	Y13						
X14	Y14						
X15	Y15						
X16	Y16						
X17	Y17						
X18	Y18	Y18	CPU selection signal				
X19	Y19	Y19	Sign of CH1 digital input				
X1A	Y1A	Y1A	Sign of CH2 digital input				
X1B	Y1B	Y1B	Output enable				
X1C	Y1C		Not used				
X1D	Y1D						
X1E	Y1E						
X1F	Y1F						

3.4.4 Buffer memory address comparison

Sequence program change is required as the assignment of buffer memory differs.

For details of the buffer memories and sequence program, refer to the Digital-Analog Converter Module User's Manual.

A62DA			Q62DAN		
Address (decimal)	Name	Read/write	Address (decimal)	Name	Read/write
0	CH1 Digital value	R/W	0	D/A conversion enable/disable	R/W
1	CH2 Digital value		1	CH1 Digital value	
2	CH1 Voltage setting value check code		2	CH2 Digital value	
3	CH2 Voltage setting value check code		3	System area (Not used)	-
4	CH1 Current setting value check code		4		
5	CH2 Current setting value check code		5		
		to			
		10			
			11	CH1 Setting value check code	R
			12	CH2 Setting value check code	
			13	System area (Not used)	-
			to		
			18		
			19	Error code	R
			20	Setting range (CH1 to CH2)	
			21	System area (Not used)	-
			22	Offset/gain setting mode Offset specification	R/W
			23	Offset/gain setting mode Gain specification	
			24	Offset/gain adjusted value specification	
			25	System area (Not used)	-
			to		
			157		
			158	Mode switching setting	R/W
			159		
			160	System area (Not used)	-
			to		
			199		
			200		
			201	System area (Not used)	-
			202	CH1 Industrial shipment settings offset value	R/W
			203	CH1 Industrial shipment settings gain value	
			204	CH2 Industrial shipment settings offset value	
			205	CH2 Industrial shipment settings gain value	
			206	CH1 User range settings offset value	
			207	CH1 User range settings gain value	
			208	CH2 User range settings offset value	
			209	CH2 User range settings gain value	

3.5 A62DA (Replacement to the Q64DAN)

3.5.1 Performance comparison

Item	A62DA																				
Digital input	Maximum setting value Voltage: ± 2000 Current: ± 1000																				
Analog output	Voltage: -10 to 0 to +10VDC (External load resistance value: 500Ω to $1M\Omega$) Current: +4 to +20mADC (External load resistance value: 0Ω to 600Ω) *Current output is usable by -20 to +20mA.																				
I/O characteristics	<table border="1"> <thead> <tr> <th rowspan="2">Digital input</th> <th colspan="2">Analog output</th> </tr> <tr> <th>Voltage</th> <th>Current</th> </tr> </thead> <tbody> <tr> <td>+2000</td> <td>+10V</td> <td>-</td> </tr> <tr> <td>+1000</td> <td>+5V</td> <td>+20mA</td> </tr> <tr> <td>0</td> <td>0V</td> <td>+4mA</td> </tr> <tr> <td>-1000</td> <td>-5V</td> <td>-12mA</td> </tr> <tr> <td>-2000</td> <td>-10V</td> <td>-</td> </tr> </tbody> </table>	Digital input	Analog output		Voltage	Current	+2000	+10V	-	+1000	+5V	+20mA	0	0V	+4mA	-1000	-5V	-12mA	-2000	-10V	-
Digital input	Analog output																				
	Voltage	Current																			
+2000	+10V	-																			
+1000	+5V	+20mA																			
0	0V	+4mA																			
-1000	-5V	-12mA																			
-2000	-10V	-																			
Maximum resolution	Voltage: 5mV (1/2000) Current: 20 μ A (1/1000)																				
Overall accuracy (accuracy at maximum analog output value)	$\pm 1\%$ (voltage: $\pm 0.1V$, current: $\pm 0.2mA$)																				
Maximum conversion speed	Within 15ms/2 channels (same time for one channel) Note) Time from when the digital input is written to when the specified analog voltage (current) is reached																				
Absolute maximum output	Voltage: $\pm 12V$ Current: $\pm 28mA$ Note) Max. output voltage and current restricted by output protection circuit																				
Number of analog output points	2 channels/module																				
Number of writes to E ² PROM	-																				
Output short protection	-																				

○: Compatible, △: Partial change required, ×: Incompatible

Q64DAN		Compatibility	Precautions for replacement																																									
16-bit signed binary (Normal resolution mode: -4096 to 4095, High resolution mode: -12288 to 12287, -16384 to 16383)		△	According to the I/O conversion characteristics used, make the output range setting and offset/gain setting of the Q64DAN.																																									
Voltage: -10 to 10VDC (External load resistance value: 1kΩ to 1MΩ) Current: 0 to 20mADC (External load resistance value: 0Ω to 600Ω)		○	The minus current cannot be output.																																									
<table border="1"> <thead> <tr> <th rowspan="2">Analog output range</th> <th colspan="2">Normal resolution mode</th> <th colspan="2">High resolution mode</th> </tr> <tr> <th>Digital input value</th> <th>Maximum resolution</th> <th>Digital input value</th> <th>Maximum resolution</th> </tr> </thead> <tbody> <tr> <td rowspan="4">Voltage</td> <td>0 to 5V</td> <td rowspan="2">0 to 4000</td> <td>1.25mV</td> <td rowspan="2">0 to 12000</td> <td>0.416mV</td> </tr> <tr> <td>1 to 5V</td> <td>1.0mV</td> <td>0.333mV</td> </tr> <tr> <td>-10 to 10V</td> <td rowspan="2">-4000 to 4000</td> <td>2.5mV</td> <td rowspan="2">-16000 to 16000</td> <td>0.625mV</td> </tr> <tr> <td>User range settings</td> <td>0.75mV</td> <td>-12000 to 12000</td> <td>0.333mV</td> </tr> <tr> <td rowspan="3">Current</td> <td>0 to 20mA</td> <td rowspan="2">0 to 4000</td> <td>5 μA</td> <td rowspan="2">0 to 12000</td> <td>1.66 μA</td> </tr> <tr> <td>4 to 20mA</td> <td>4 μA</td> <td>1.33 μA</td> </tr> <tr> <td>User range settings</td> <td>-4000 to 4000</td> <td>1.5 μA</td> <td>-12000 to 12000</td> <td>0.83 μA</td> </tr> </tbody> </table>		Analog output range	Normal resolution mode		High resolution mode		Digital input value	Maximum resolution	Digital input value	Maximum resolution	Voltage	0 to 5V	0 to 4000	1.25mV	0 to 12000	0.416mV	1 to 5V	1.0mV	0.333mV	-10 to 10V	-4000 to 4000	2.5mV	-16000 to 16000	0.625mV	User range settings	0.75mV	-12000 to 12000	0.333mV	Current	0 to 20mA	0 to 4000	5 μA	0 to 12000	1.66 μA	4 to 20mA	4 μA	1.33 μA	User range settings	-4000 to 4000	1.5 μA	-12000 to 12000	0.83 μA	△	According to the I/O conversion characteristics used, make the output range setting and offset/gain setting of the Q64DAN.
Analog output range	Normal resolution mode		High resolution mode																																									
	Digital input value	Maximum resolution	Digital input value	Maximum resolution																																								
Voltage	0 to 5V	0 to 4000	1.25mV	0 to 12000	0.416mV																																							
	1 to 5V		1.0mV		0.333mV																																							
	-10 to 10V	-4000 to 4000	2.5mV	-16000 to 16000	0.625mV																																							
	User range settings		0.75mV		-12000 to 12000	0.333mV																																						
Current	0 to 20mA	0 to 4000	5 μA	0 to 12000	1.66 μA																																							
	4 to 20mA		4 μA		1.33 μA																																							
	User range settings	-4000 to 4000	1.5 μA	-12000 to 12000	0.83 μA																																							
Ambient temperature 25±5°C: within ±0.1% (voltage: ±10mV, current: ±20μA) Ambient temperature 0 to 55°C: within ±0.3% (voltage: ±30mV, current: ±60μA)		○																																										
80μs/channel		○																																										
Voltage: ±12V Current: 21mA		△	The minus current cannot be output.																																									
4 channels/module		○																																										
Max. 100,000 times		○																																										
Available		○																																										

Item		A62DA
Isolation method		Between the output terminal and programmable controller power supply: photocoupler isolation (Between channels: non-isolation)
Dielectric withstand voltage		-
Insulation resistance		-
Number of occupied I/O points		32 points (I/O assignment: special 32 points)
Connected terminal		20-point terminal block
Applicable wire size		0.75 to 2mm ² (Applicable tightening torque: 39 to 59N•cm)
Applicable solderless terminal		V1.25-3, V1.25-YS3A, V2-S3, V2-YS3A
Internal current consumption (5VDC)		0.6A
External power supply	Voltage	21.6 to 26.4VDC
	Current consumption	0.35A
	Inrush current	2.4A
Weight		0.5kg

○ : Compatible, △ : Partial change required, × : Incompatible

Q64DAN		Compatibility	Precautions for replacement
Between the I/O terminal and programmable controller power supply: photocoupler isolation Between output channels: non-isolation Between external power supply and analog output: transformer isolation		○	
Between the I/O terminal and programmable controller power supply: 500VAC, for 1 minute		○	
Between the I/O terminal and programmable controller power supply: 500VDC, 20MΩ or more		○	
16 points (I/O assignment: intelligent 16 points)		△	The number of occupied I/O points has changed to 16 points.
18-point terminal block		×	Wiring change is required.
0.3 to 0.75mm ²		×	
R1.25-3 (Sleeved solderless terminal cannot be used.)		×	
0.34A		○	
24VDC +20%, -15% Ripple, spike 500mV _{P-P} or less		○	
0.24A		○	
2.5A, 260μs or less		○	
0.20kg		○	

3.5.2 Functional comparison

○ : Available, - : Not available

Item	Description	A62DA	Q64DAN	Precautions for replacement
Analog output HOLD/CLEAR function	Retains an analog value that was output when the programmable controller CPU is in the STOP status or an error occurs.	-	○	
D/A conversion enable/disable function	Specifies whether to enable or disable the D/A conversion.	-	○	
D/A output enable/disable function	Specifies whether to output the D/A conversion value or the offset value.	○	○	The Q64DAN specifies whether to enable or disable output for each channel.
Synchronous output function	Obtains analog output synchronized with the programmable controller CPU.	-	○	
Analog output test while the programmable controller CPU is in the STOP status	Outputs the analog value converted from a digital value when CH□ Output enable/disable flag is forcibly turned on while the programmable controller CPU is in the STOP status.	-	○	
Resolution mode	Switches the resolution mode according to the application. The resolution can be selected from 1/4000, 1/12000, or 1/16000. The resolution mode is batch-set for all channels.	-	○	
Online module replacement	Replaces a module without stopping the system.	-	○	Replaceable modules during online are the Process CPU and the Redundant CPU.

3.5.3 I/O signal comparison to programmable controller CPU

Sequence program change is required as the I/O signals differ.

For details of the I/O signals and sequence program, refer to the Digital-Analog Converter Module User's Manual.

A62DA				Q64DAN			
Device No.	Signal name	Device No.	Signal name	Device No.	Signal name	Device No.	Signal name
X0	Watchdog timer error	Y0		X0	Module READY	Y0	Not used
X1	D/A conversion READY	Y1		X1		Y1	CH1 Output enable/disable flag
X2		Y2		X2		Y2	CH2 Output enable/disable flag
X3		Y3		X3	Not used	Y3	CH3 Output enable/disable flag
X4		Y4		X4		Y4	CH4 Output enable/disable flag
X5		Y5		X5		Y5	
X6		Y6		X6		Y6	
X7		Y7		X7		Y7	Not used
X8		Y8		X8	High resolution mode status flag	Y8	
X9		Y9		X9	Operating condition setting completion flag	Y9	Operating condition setting request
XA		YA	Not used	XA	Offset/gain setting mode status flag	YA	User range write request
XB		YB		XB	Channel change completion flag	YB	Channel change request
XC		YC		XC	Setting value change completion flag	YC	Setting value change request
XD	Not used	YD		XD	Synchronous output mode flag	YD	Synchronous output request
XE		YE		XE	Not used	YE	Not used
XF		YF		XF	Error flag	YF	Error clear request
X10		Y10					
X11		Y11					
X12		Y12					
X13		Y13					
X14		Y14					
X15		Y15					
X16		Y16					
X17		Y17					
X18		Y18	CPU selection signal				
X19		Y19	Sign of CH1 digital input				
X1A		Y1A	Sign of CH2 digital input				
X1B		Y1B	Output enable				
X1C		Y1C					
X1D		Y1D	Not used				
X1E		Y1E					
X1F		Y1F					

3.5.4 Buffer memory address comparison

Sequence program change is required as the assignment of buffer memory differs.

For details of the buffer memories and sequence program, refer to the Digital-Analog Converter Module User's Manual.

A62DA			Q64DAN		
Address (decimal)	Name	Read/write	Address (decimal)	Name	Read/write
0	CH1 Digital value	R/W	0	D/A conversion enable/disable	R/W
1	CH2 Digital value		1	CH1 Digital value	
2	CH1 Voltage setting value check code		2	CH2 Digital value	
3	CH2 Voltage setting value check code		3	CH3 Digital value	
4	CH1 Current setting value check code		4	CH4 Digital value	
5	CH2 Current setting value check code		5	System area (Not used)	
		to			
		10			
			11	CH1 Setting value check code	R
			12	CH2 Setting value check code	
			13	CH3 Setting value check code	
			14	CH4 Setting value check code	
			15	System area (Not used)	-
			to		
			18		
			19	Error code	R
			20	Setting range (CH1 to CH4)	
			21	System area (Not used)	-
			22	Offset/gain setting mode Offset specification	R/W
			23	Offset/gain setting mode Gain specification	
			24	Offset/gain adjusted value specification	
			25	System area (Not used)	-
			to		
			157		
			158	Mode switching setting	R/W
			159		
			160	System area (Not used)	-
			to		
			199		
			200		
			201	System area (Not used)	-
			204	CH2 Industrial shipment settings offset value	R/W
			205	CH2 Industrial shipment settings gain value	
			206	CH3 Industrial shipment settings offset value	
			207	CH3 Industrial shipment settings gain value	
			208	CH4 Industrial shipment settings offset value	
			209	CH4 Industrial shipment settings gain value	
			210	CH1 User range settings offset value	
			211	CH1 User range settings gain value	
			212	CH2 User range settings offset value	
			213	CH2 User range settings gain value	
			214	CH3 User range settings offset value	
			215	CH3 User range settings gain value	
			216	CH4 User range settings offset value	
			217	CH4 User range settings gain value	

3.6 A62DA-S1 (Replacement to the Q62DAN)

3.6.1 Performance comparison

Item		A62DA-S1																		
Digital input		0 to +4000																		
Analog output		Voltage: 0 to +10VDC (External load resistance value: 500Ω to 1MΩ) Current: +4 to +20mADC (External load resistance value: 0Ω to 600Ω) *Current output is usable by 0 to +20mA.																		
I/O characteristics		<table border="1"> <thead> <tr> <th>Output range</th> <th>Digital input</th> <th>Analog output</th> </tr> </thead> <tbody> <tr> <td rowspan="2">0 to 10V</td> <td>+ 4000</td> <td>+ 10V</td> </tr> <tr> <td>0</td> <td>0V</td> </tr> <tr> <td rowspan="2">0 to 5V</td> <td>+ 4000</td> <td>+ 5V or + 20mA</td> </tr> <tr> <td>0</td> <td>0V or 0mA</td> </tr> <tr> <td rowspan="2">1 to 5V</td> <td>+ 4000</td> <td>+ 5V or + 20mA</td> </tr> <tr> <td>0</td> <td>+ 1V or + 4mA</td> </tr> </tbody> </table>	Output range	Digital input	Analog output	0 to 10V	+ 4000	+ 10V	0	0V	0 to 5V	+ 4000	+ 5V or + 20mA	0	0V or 0mA	1 to 5V	+ 4000	+ 5V or + 20mA	0	+ 1V or + 4mA
Output range	Digital input	Analog output																		
0 to 10V	+ 4000	+ 10V																		
	0	0V																		
0 to 5V	+ 4000	+ 5V or + 20mA																		
	0	0V or 0mA																		
1 to 5V	+ 4000	+ 5V or + 20mA																		
	0	+ 1V or + 4mA																		
Maximum resolution	Voltage	1 to 5V: 1mV (1/4000) 0 to 5V: 1.25mV (1/4000) 0 to 10V: 2.5mV (1/4000)																		
	Current	4 to 20mA: 4μA (1/4000) 0 to 20mA: 5μA (1/4000)																		
Overall accuracy (accuracy at maximum analog output value)		(Refer to *1.)																		
Maximum conversion speed		Within 15ms/2 channels (same time for one channel) Note) Time from when the digital input is written to when the specified analog voltage (current) is reached																		
Absolute maximum output		Voltage: 0 to +12V Current: 0 to +28mA Note) Max. output voltage and current restricted by output protection circuit																		
Number of analog output points		2 channels/module																		
Number of writes to E ² PROM		-																		
Output short protection		-																		

*1 Indicates accuracy at the maximum analog output value of the A62DA-S1.

Temperature range	Output range				
	1 to 5V	0 to 5V	0 to 10V	4 to 20mA	0 to 20mA
25°C (within ±0.5%)	±25mV	±25mV	±50mV	±0.1mA	±0.1mA
0 to 55°C (within ±1%)	±50mV	±50mV	±100mV	±0.2mA	±0.2mA

○: Compatible, △: Partial change required, ×: Incompatible

		Q62DAN				Compatibility	Precautions for replacement
		16-bit signed binary Normal resolution mode: -4096 to 4095, High resolution mode: -12288 to 12287, -16384 to 16383				○	
		Voltage: -10 to 10VDC (External load resistance value: 1kΩ to 1MΩ) Current: 0 to 20mADC (External load resistance value: 0Ω to 600Ω)				○	
	Analog output range	Normal resolution mode		High resolution mode		○	
		Digital input value	Maximum resolution	Digital input value	Maximum resolution		
Voltage	0 to 5V	0 to 4000	1.25mV	0 to 12000	0.416mV		
	1 to 5V		1.0mV		0.333mV		
Voltage	-10 to 10V	-4000 to 4000	2.5mV	-16000 to 16000	0.625mV		
	User range settings		0.75mV	-12000 to 12000	0.333mV		
Current	0 to 20mA	0 to 4000	5 μA	0 to 12000	1.66 μA		
	4 to 20mA		4 μA		1.33 μA		
	User range settings	-4000 to 4000	1.5 μA	-12000 to 12000	0.83 μA		
		Ambient temperature 25±5°C: within ±0.1% (voltage: ±10mV, current: ±20μA) Ambient temperature 0 to 55°C: within ±0.3% (voltage: ±30mV, current: ±60μA)				○	
		80μs/channel				○	
		Voltage: ±12V Current: 21mA				○	
		2 channels/module				○	
		Max. 100,000 times				○	
		Available				○	

Item		A62DA-S1	
Isolation method		Between the output terminal and programmable controller power supply: photocoupler isolation (Between channels: non-isolation)	
Dielectric withstand voltage		-	
Insulation resistance		-	
Number of occupied I/O points		32 points (I/O assignment: special 32 points)	
Connected terminal		20-point terminal block	
Applicable wire size		0.75 to 2mm ² (Applicable tightening torque: 39 to 59N•cm)	
Applicable solderless terminal		V1.25-3, V1.25-YS3A, V2-S3, V2-YS3A	
Internal current consumption (5VDC)		0.6A	
External power supply	Voltage	21.6 to 26.4VDC	
	Current consumption	0.35A	
	Inrush current	2.4A	
Weight		0.5kg	

○ : Compatible, △ : Partial change required, × : Incompatible

	Q62DAN	Compatibility	Precautions for replacement
	Between the I/O terminal and programmable controller power supply: photocoupler isolation Between output channels: non-isolation Between external power supply and analog output: transformer isolation	○	
	Between the I/O terminal and programmable controller power supply: 500VAC, for 1 minute	○	
	Between the I/O terminal and programmable controller power supply: 500VDC, 20MΩ or more	○	
	16 points (I/O assignment: intelligent 16 points)	△	The number of occupied I/O points has changed to 16 points.
	18-point terminal block	×	Wiring change is required.
	0.3 to 0.75mm ²	×	
	R1.25-3 (Sleeved solderless terminal cannot be used.)	×	
	0.33A	○	
	24VDC +20%, -15% Ripple, spike 500mV _{P-P} or less	○	
	0.15A	○	
	2.5A, 250μs or less	○	
	0.19kg	○	

3.6.2 Functional comparison

○ : Available, - : Not available

Item	Description	A62DA-S1	Q62DAN	Precautions for replacement
Analog output HOLD/CLEAR function	Retains an analog value before Output enable signal turns off when the Output enable signal is off.	○	○	1) Refer to ("Analog output status combination list" in the Digital-Analog Converter Module User's Manual to check the execution status of output. 2) For the Q62DAN, this function is set with the intelligent function module switch setting.
D/A conversion enable/disable function	Specifies whether to enable or disable the D/A conversion.	-	○	
D/A output enable/disable function	Specifies whether to output the D/A conversion value or the offset value.	○	○	The Q62DAN specifies whether to enable or disable output for each channel.
Synchronous output function	Obtains analog output synchronized with the programmable controller CPU.	-	○	
Analog output test while the programmable controller CPU is in the STOP status	Outputs the analog value converted from a digital value when CH□ Output enable/disable flag is forcibly turned on while the programmable controller CPU is in the STOP status.	-	○	
Resolution mode	Switches the resolution mode according to the application. The resolution can be selected from 1/4000, 1/12000, or 1/16000. The resolution mode is batch-set for all channels.	-	○	
Online module replacement	Replaces a module without stopping the system.	-	○	Replaceable modules during online are the Process CPU and the Redundant CPU.

3.6.3 I/O signal comparison to programmable controller CPU

Sequence program change is required as the I/O signals differ.

For details of the I/O signals and sequence program, refer to the Digital-Analog Converter Module User's Manual.

A62DA-S1				Q62DAN			
Device No.	Signal name	Device No.	Signal name	Device No.	Signal name	Device No.	Signal name
X0	Watchdog timer error	Y0	Not used	X0	Module READY	Y0	Not used
X1	D/A conversion READY	Y1		X1	Not used	Y1	CH1 Output enable/disable flag
X2	Not used	Y2		X2		Y2	CH2 Output enable/disable flag
X3		Y3		X3		Y3	Not used
X4		Y4		X4		Y4	
X5		Y5		X5		Y5	
X6		Y6		X6		Y6	
X7		Y7		X7		Y7	
X8		Y8		X8	High resolution mode status flag	Y8	
X9		Y9		X9	Operating condition setting completion flag	Y9	Operating condition setting request
XA		YA		XA	Offset/gain setting mode status flag	YA	User range write request
XB		YB		XB	Channel change completion flag	YB	Channel change request
XC		YC		XC	Setting value change completion flag	YC	Setting value change request
XD		YD		XD	Synchronous output mode flag	YD	Synchronous output request
XE		YE		XE	Not used	YE	Not used
XF	YF	XF		Error flag	YF	Error clear request	
X10	Y10						
X11	Y11						
X12	Y12						
X13	Y13						
X14	Y14						
X15	Y15						
X16	Y16						
X17	Y17						
X18	Y18						
X19	Y19						
X1A	Y1A						
X1B	Y1B		Output enable				
X1C	Y1C		Not used				
X1D	Y1D						
X1E	Y1E						
X1F	Y1F						

3.6.4 Buffer memory address comparison

Sequence program change is required as the assignment of buffer memory differs.

For details of the buffer memories and sequence program, refer to the Digital-Analog Converter Module User's Manual.

A62DA-S1			Q62DAN		
Address (decimal)	Name	Read/write	Address (decimal)	Name	Read/write
0	CH1 Digital value	R/W	0	D/A conversion enable/disable	R/W
1	CH2 Digital value		1	CH1 Digital value	
2	CH1 Upper limit check code		2	CH2 Digital value	
3	CH1 Lower limit check code		3	System area (Not used)	-
4	CH2 Upper limit check code		4		
5	CH2 Lower limit check code		5		
		to			
		10			
			11	CH1 Setting value check code	R
			12	CH2 Setting value check code	
			13	System area (Not used)	-
			to		
			18		
			19	Error code	R
			20	Setting range (CH1 to CH2)	
			21	System area (Not used)	-
			22	Offset/gain setting mode Offset specification	R/W
			23	Offset/gain setting mode Gain specification	
			24	Offset/gain adjusted value specification	
			25	System area (Not used)	-
			to		
			157		
			158	Mode switching setting	R/W
			159		
			160	System area (Not used)	-
			to		
			199		
			200		
			201	System area (Not used)	-
			202	CH1 Industrial shipment settings offset value	R/W
			203	CH1 Industrial shipment settings gain value	
			204	CH2 Industrial shipment settings offset value	
			205	CH2 Industrial shipment settings gain value	
			206	CH1 User range settings offset value	
			207	CH1 User range settings gain value	
			208	CH2 User range settings offset value	
			209	CH2 User range settings gain value	

3.7 A62DA-S1 (Replacement to the Q64DAN)

3.7.1 Performance comparison

Item		A62DA-S1																		
Digital input		0 to +4000																		
Analog output		Voltage: 0 to +10VDC (External load resistance value: 500Ω to 1MΩ) Current: +4 to +20mADC (External load resistance value: 0Ω to 600Ω) *Current output is usable by 0 to +20mA.																		
I/O characteristics		<table border="1"> <thead> <tr> <th>Output range</th> <th>Digital input</th> <th>Analog output</th> </tr> </thead> <tbody> <tr> <td rowspan="2">0 to 10V</td> <td>+ 4000</td> <td>+ 10V</td> </tr> <tr> <td>0</td> <td>0V</td> </tr> <tr> <td rowspan="2">0 to 5V</td> <td>+ 4000</td> <td>+ 5V or + 20mA</td> </tr> <tr> <td>0</td> <td>0V or 0mA</td> </tr> <tr> <td rowspan="2">1 to 5V</td> <td>+ 4000</td> <td>+ 5V or + 20mA</td> </tr> <tr> <td>0</td> <td>+ 1V or + 4mA</td> </tr> </tbody> </table>	Output range	Digital input	Analog output	0 to 10V	+ 4000	+ 10V	0	0V	0 to 5V	+ 4000	+ 5V or + 20mA	0	0V or 0mA	1 to 5V	+ 4000	+ 5V or + 20mA	0	+ 1V or + 4mA
Output range	Digital input	Analog output																		
0 to 10V	+ 4000	+ 10V																		
	0	0V																		
0 to 5V	+ 4000	+ 5V or + 20mA																		
	0	0V or 0mA																		
1 to 5V	+ 4000	+ 5V or + 20mA																		
	0	+ 1V or + 4mA																		
Maximum resolution	Voltage	1 to 5V: 1mV (1/4000) 0 to 5V: 1.25mV (1/4000) 0 to 10V: 2.5mV (1/4000)																		
	Current	4 to 20mA: 4μA (1/4000) 0 to 20mA: 5μA (1/4000)																		
Overall accuracy (accuracy at maximum analog output value)		(Refer to *1.)																		
Maximum conversion speed		Within 15ms/2 channels (same time for one channel) Note) Time from when the digital input is written to when the specified analog voltage (current) is reached																		
Absolute maximum output		Voltage: 0 to +12V Current: 0 to +28mA Note) Max. output voltage and current restricted by output protection circuit																		
Number of analog output points		2 channels/module																		
Number of writes to E ² PROM		-																		
Output short protection		-																		

*1 Indicates accuracy at the maximum analog output value of the A62DA-S1.

Temperature range	Output range				
	1 to 5V	0 to 5V	0 to 10V	4 to 20mA	0 to 20mA
25°C (within ±0.5%)	±25mV	±25mV	±50mV	±0.1mA	±0.1mA
0 to 55°C (within ±1%)	±50mV	±50mV	±100mV	±0.2mA	±0.2mA

○: Compatible, △: Partial change required, ×: Incompatible

		Q64DAN				Compatibility	Precautions for replacement																																										
		16-bit signed binary (Normal resolution mode: -4096 to 4095, High resolution mode: -12288 to 12287, -16384 to 16383)				○																																											
		Voltage: -10 to 10VDC (External load resistance value: 1kΩ to 1MΩ) Current: 0 to 20mADC (External load resistance value: 0Ω to 600Ω)				○																																											
		<table border="1"> <thead> <tr> <th colspan="2" rowspan="2">Analog output range</th> <th colspan="2">Normal resolution mode</th> <th colspan="2">High resolution mode</th> </tr> <tr> <th>Digital input value</th> <th>Maximum resolution</th> <th>Digital input value</th> <th>Maximum resolution</th> </tr> </thead> <tbody> <tr> <td rowspan="4">Voltage</td> <td>0 to 5V</td> <td rowspan="2">0 to 4000</td> <td>1.25mV</td> <td rowspan="2">0 to 12000</td> <td>0.416mV</td> </tr> <tr> <td>1 to 5V</td> <td>1.0mV</td> <td>0.333mV</td> </tr> <tr> <td>-10 to 10V</td> <td rowspan="2">-4000 to 4000</td> <td>2.5mV</td> <td>-16000 to 16000</td> <td>0.625mV</td> </tr> <tr> <td>User range settings</td> <td>0.75mV</td> <td>-12000 to 12000</td> <td>0.333mV</td> </tr> <tr> <td rowspan="3">Current</td> <td>0 to 20mA</td> <td rowspan="2">0 to 4000</td> <td>5 μA</td> <td rowspan="2">0 to 12000</td> <td>1.66 μA</td> </tr> <tr> <td>4 to 20mA</td> <td>4 μA</td> <td>1.33 μA</td> </tr> <tr> <td>User range settings</td> <td>-4000 to 4000</td> <td>1.5 μA</td> <td>-12000 to 12000</td> <td>0.83 μA</td> </tr> </tbody> </table>				Analog output range		Normal resolution mode		High resolution mode		Digital input value	Maximum resolution	Digital input value	Maximum resolution	Voltage	0 to 5V	0 to 4000	1.25mV	0 to 12000	0.416mV	1 to 5V	1.0mV	0.333mV	-10 to 10V	-4000 to 4000	2.5mV	-16000 to 16000	0.625mV	User range settings	0.75mV	-12000 to 12000	0.333mV	Current	0 to 20mA	0 to 4000	5 μA	0 to 12000	1.66 μA	4 to 20mA	4 μA	1.33 μA	User range settings	-4000 to 4000	1.5 μA	-12000 to 12000	0.83 μA	○	
Analog output range		Normal resolution mode		High resolution mode																																													
		Digital input value	Maximum resolution	Digital input value	Maximum resolution																																												
Voltage	0 to 5V	0 to 4000	1.25mV	0 to 12000	0.416mV																																												
	1 to 5V		1.0mV		0.333mV																																												
	-10 to 10V	-4000 to 4000	2.5mV	-16000 to 16000	0.625mV																																												
	User range settings		0.75mV	-12000 to 12000	0.333mV																																												
Current	0 to 20mA	0 to 4000	5 μA	0 to 12000	1.66 μA																																												
	4 to 20mA		4 μA		1.33 μA																																												
	User range settings	-4000 to 4000	1.5 μA	-12000 to 12000	0.83 μA																																												
		Ambient temperature 25±5°C: within ±0.1% (voltage: ±10mV, current: ±20μA) Ambient temperature 0 to 55°C: within ±0.3% (voltage: ±30mV, current: ±60μA)				○																																											
		80μs/channel				○																																											
		Voltage: ±12V Current: 21mA				○																																											
		4 channels/module				○																																											
		Max. 100,000 times				○																																											
		Available				○																																											

Item		A62DA-S1	
Isolation method		Between the output terminal and programmable controller power supply: photocoupler isolation (Between channels: non-isolation)	
Dielectric withstand voltage		-	
Insulation resistance		-	
Number of occupied I/O points		32 points (I/O assignment: special 32 points)	
Connected terminal		20-point terminal block	
Applicable wire size		0.75 to 2mm ² (Applicable tightening torque: 39 to 59N•cm)	
Applicable solderless terminal		V1.25-3, V1.25-YS3A, V2-S3, V2-YS3A	
Internal current consumption (5VDC)		0.6A	
External power supply	Voltage	21.6 to 26.4VDC	
	Current consumption	0.35A	
	Inrush current	2.4A	
Weight		0.5kg	

○ : Compatible, △ : Partial change required, × : Incompatible

	Q64DAN	Compatibility	Precautions for replacement
	Between the I/O terminal and programmable controller power supply: photocoupler isolation Between output channels: non-isolation Between external power supply and analog output: transformer Isolation	○	
	Between the I/O terminal and programmable controller power supply: 500VAC, for 1 minute	○	
	Between the I/O terminal and programmable controller power supply: 500VDC, 20MΩ or more	○	
	16 points (I/O assignment: intelligent 16 points)	△	The number of occupied I/O points has changed to 16 points.
	18-point terminal block	×	Wiring change is required.
	0.3 to 0.75mm ²	×	
	R1.25-3 (Sleeved solderless terminal cannot be used.)	×	
	0.34A	○	
	24VDC +20%, -15% Ripple, spike 500mV _{P-P} or less	○	
	0.24A	○	
	2.5A, 260μs or less	○	
	0.20kg	○	

3.7.2 Functional comparison

○ : Available, - : Not available

Item	Description	A62DA-S1	Q64DAN	Precautions for replacement
Analog output HOLD/CLEAR function	Retains an analog value before Output enable signal turns off when the Output enable signal is off.	○	○	1) Refer to ("Analog output status combination list" in the Digital-Analog Converter Module User's Manual to check the execution status of output. 2) For the Q64DAN, this function is set with the intelligent function module switch setting.
D/A conversion enable/disable function	Specifies whether to enable or disable the D/A conversion.	-	○	
D/A output enable/disable function	Specifies whether to output the D/A conversion value or the offset value.	○	○	The Q64DAN specifies whether to enable or disable output for each channel.
Synchronous output function	Obtains analog output synchronized with the programmable controller CPU.	-	○	
Analog output test while the programmable controller CPU is in the STOP status	Outputs the analog value converted from a digital value when CH□ Output enable/disable flag is forcibly turned on while the programmable controller CPU is in the STOP status.	-	○	
Resolution mode	Switches the resolution mode according to the application. The resolution can be selected from 1/4000, 1/12000, or 1/16000. The resolution mode is batch-set for all channels.	-	○	
Online module replacement	Replaces a module without stopping the system.	-	○	Replaceable modules during online are the Process CPU and the Redundant CPU.

3.7.3 I/O signal comparison to programmable controller CPU

Sequence program change is required as the I/O signals differ.

For details of the I/O signals and sequence program, refer to the Digital-Analog Converter Module User's Manual.

A62DA-S1				Q64DAN			
Device No.	Signal name	Device No.	Signal name	Device No.	Signal name	Device No.	Signal name
X0	Watchdog timer error	Y0	Not used	X0	Module READY	Y0	Not used
X1	D/A conversion READY	Y1		X1	Not used	Y1	CH1 Output enable/disable flag
X2	Not used	Y2		X2		Y2	CH2 Output enable/disable flag
X3		Y3		X3		Y3	CH3 Output enable/disable flag
X4		Y4		X4		Y4	CH4 Output enable/disable flag
X5		Y5		X5		Y5	Not used
X6		Y6		X6		Y6	
X7		Y7		X7		Y7	
X8		Y8		X8		High resolution mode status flag	Y8
X9		Y9		X9	Operating condition setting completion flag	Y9	Operating condition setting request
XA		YA		XA	Offset/gain setting mode status flag	YA	User range write request
XB		YB		XB	Channel change completion flag	YB	Channel change request
XC	YC	XC		Setting value change completion flag	YC	Setting value change request	
XD	YD	XD		Synchronous output mode flag	YD	Synchronous output request	
XE	YE	XE		Not used	YE	Not used	
XF	YF	XF		Error flag	YF	Error clear request	
X10	Y10						
X11	Y11						
X12	Y12						
X13	Y13						
X14	Y14						
X15	Y15						
X16	Y16						
X17	Y17						
X18	Y18						
X19	Y19						
X1A	Y1A						
X1B	Y1B	Y1B	Output enable				
X1C	Y1C						
X1D	Y1D	Y1D	Not used				
X1E	Y1E	Y1E					
X1F	Y1F	Y1F					

3.7.4 Buffer memory address comparison

Sequence program change is required as the assignment of buffer memory differs.

For details of the buffer memories and sequence program, refer to the Digital-Analog Converter Module User's Manual.

A62DA-S1			Q64DAN		
Address (decimal)	Name	Read/write	Address (decimal)	Name	Read/write
0	CH1 Digital value	R/W	0	D/A conversion enable/disable	R/W
1	CH2 Digital value		1	CH1 Digital value	
2	CH1 Voltage upper limit check code		2	CH2 Digital value	
3	CH2 Voltage lower limit check code		3	CH3 Digital value	
4	CH1 Current upper limit check code		4	CH4 Digital value	
5	CH2 Current lower limit check code		5		
			to	System area (Not used)	-
			10		
			11	CH1 Setting value check code	R
			12	CH2 Setting value check code	
			13	CH3 Setting value check code	
			14	CH4 Setting value check code	
			15		
			to	System area (Not used)	-
			18		
			19	Error code	R
			20	Setting range (CH1 to CH4)	
			21	System area (Not used)	-
			22	Offset/gain setting mode Offset specification	R/W
			23	Offset/gain setting mode Gain specification	
			24	Offset/gain adjusted value specification	
			25		
			to	System area (Not used)	-
			157		
			158	Mode switching setting	R/W
			159		
			160		
			to	System area (Not used)	-
			199		
			200	Pass data classification setting	R/W
			201	System area (Not used)	-
			202	CH1 Industrial shipment settings offset value	R/W
			203	CH1 Industrial shipment settings gain value	
			204	CH2 Industrial shipment settings offset value	
			205	CH2 Industrial shipment settings gain value	
			206	CH3 Industrial shipment settings offset value	
			207	CH3 Industrial shipment settings gain value	
			208	CH4 Industrial shipment settings offset value	
			209	CH4 Industrial shipment settings gain value	
			210	CH1 User range settings offset value	
			211	CH1 User range settings gain value	
			212	CH2 User range settings offset value	
			213	CH2 User range settings gain value	
			214	CH3 User range settings offset value	
			215	CH3 User range settings gain value	
			216	CH4 User range settings offset value	
			217	CH4 User range settings gain value	

3.8 A68DAI(-S1)

3.8.1 Performance comparison

Item		A68DAI (-S1)				
Digital input		(1)16-bit signed binary				
		(2)Setting range:				
		Set resolution		Setting range		
		1/4000	1/8000	1/12000	0 to 12000	
Analog output		0 to 20mADC (External load resistance value: 0Ω to 600Ω)				
I/O characteristics		Digital value resolution			*Analog output value	
		1/4000	1/8000	1/12000		
		Digital input	4000	8000	12000	+20mA
		value	2000	4000	6000	+12mA
		0	0	0	+4mA	
		*When offset value 4mA, gain value 20mA settings				
Maximum resolution of analog value	1/4000	5.0μA				
	1/8000	2.5μA				
	1/12000	1.6μA				
Overall accuracy (accuracy at maximum analog output value)		±1.0% (±200μA)				
Conversion speed		Within 40ms/8 channels (same time for one channel) Note) Time from when the digital input is written to when the specified analog value is reached				
Absolute maximum output		0 to +28mA Note) Max. output current restricted by output protection circuit				
Number of analog output points		8 channels/module				

○: Compatible, △: Partial change required, ×: Incompatible

		Q68DAIN				Compatibility	Precautions for replacement																								
		16-bit signed binary (Normal resolution mode: -4096 to 4095, High resolution mode: -12288 to 12287)				○																									
		0 to 20mADC (External load resistance value: 0Ω to 600Ω)				○																									
		<table border="1"> <thead> <tr> <th colspan="2" rowspan="2">Analog output range</th> <th colspan="2">Normal resolution mode</th> <th colspan="2">High resolution mode</th> </tr> <tr> <th>Digital input value</th> <th>Maximum resolution</th> <th>Digital input value</th> <th>Maximum resolution</th> </tr> </thead> <tbody> <tr> <td rowspan="3">Current</td> <td>0 to 20mA</td> <td rowspan="2">0 to 4000</td> <td>5μA</td> <td rowspan="2">0 to 12000</td> <td>1.66μA</td> </tr> <tr> <td>4 to 20mA</td> <td>4μA</td> <td>1.33μA</td> </tr> <tr> <td>User range settings</td> <td>-4000 to 4000</td> <td>1.5μA</td> <td>-12000 to 12000</td> <td>0.83μA</td> </tr> </tbody> </table>				Analog output range		Normal resolution mode		High resolution mode		Digital input value	Maximum resolution	Digital input value	Maximum resolution	Current	0 to 20mA	0 to 4000	5μA	0 to 12000	1.66μA	4 to 20mA	4μA	1.33μA	User range settings	-4000 to 4000	1.5μA	-12000 to 12000	0.83μA	○	
Analog output range		Normal resolution mode		High resolution mode																											
		Digital input value	Maximum resolution	Digital input value	Maximum resolution																										
Current	0 to 20mA	0 to 4000	5μA	0 to 12000	1.66μA																										
	4 to 20mA		4μA		1.33μA																										
	User range settings	-4000 to 4000	1.5μA	-12000 to 12000	0.83μA																										
		Ambient temperature 25±5°C: within ±0.1% (±20μA) Ambient temperature 0 to 55°C: within ±0.3% (±60μA)				○																									
		80μs/channel				○																									
		21mA				○																									
		8 channels/module				○																									

Item		A68DAI (-S1)	
Number of writes to E ² PROM		-	
Output short protection		-	
Isolation method		Between the output terminal and programmable controller power supply: photocoupler isolation (Between channels: non-isolation)	
Dielectric withstand voltage		-	
Insulation resistance		-	
Number of occupied I/O points		32 points (I/O assignment: special 32 points)	
Connected terminal		38-point terminal block	
Applicable wire size		0.75 to 2mm ² (Applicable tightening torque: 39 to 59N•cm)	
Applicable solderless terminal		V1.25-3, V1.25-YS3A, V2-S3, V2-YS3A	
Internal current consumption (5VDC)		0.15A	
External power supply	Voltage	21.6 to 26.4VDC	
	Current consumption	0.4A	
	Inrush current	-	
Weight		0.65kg	

○ : Compatible, △ : Partial change required, × : Incompatible

	Q68DAIN	Compatibility	Precautions for replacement
	Max. 100,000 times	○	
	Available	○	
	Between the I/O terminal and programmable controller power supply: photocoupler isolation Between output channels: non-isolation Between external power supply and analog output: transformer isolation	○	
	Between the I/O terminal and programmable controller power supply: 500VAC, for 1 minute	○	
	Between the I/O terminal and programmable controller power supply: 500VDC, 20MΩ or more	○	
	16 points (I/O assignment: intelligent 16 points)	△	The number of occupied I/O points has changed to 16 points.
	18-point terminal block	×	Wiring change is required.
	0.3 to 0.75mm ²	×	
	FG terminal: R1.25-3, 1.25-YS3, RAV1.25-3, V1.25-YS3A Terminals other than FG: R1.25-3 (Sleeved solderless terminal cannot be used.)	×	
	0.38A	△	The recalculation of internal current consumption (5VDC) is required.
	24VDC +20%, -15% Ripple, spike 500mVp-p or less	○	
	0.27A		
	2.5A, 230μs or less	-	
	0.20kg	○	

3.8.2 Functional comparison

○ : Available, - : Not available

Item	Description	A68DAI (-S1)	Q68 DAIN	Precautions for replacement																	
D/A conversion enable/disable function	Specifies whether to enable or disable the D/A conversion for each channel.	○	○	On Q68DAIN, by disabling the D/A conversion for the channels that are not used, the conversion speed can be shortened.																	
D/A output enable/disable function	Specifies whether to output the D/A conversion value or the offset value for each channel. The conversion speed stays constant regardless of whether D/A output is enabled or disabled.	○	○	On Q68DAIN, the output enable/disable is set with Y signal (CH□ Output enable/disable flag).																	
Synchronous output function	Obtains analog output synchronized with the programmable controller CPU. The analog output will be updated after Synchronous output request (YD) is set to ON and the time specified as "programmable controller CPU processing time + 120μs" has elapsed. However, the analog output will be fixed to CH1, and other channels (CH2 to CH8) cannot be used. When the module is mounted on a remote I/O station, the analog output will not be synchronized because of a link scan delay if the synchronous output function is specified.	-	○																		
Analog output HOLD/CLEAR function	Retains an analog value that was output when the programmable controller CPU is in the STOP status or an error occurs.	○	○	<ol style="list-style-type: none"> 1) On Q68DAIN, the setting of HOLD/CLEAR is carried out for each channel. 2) For the Q68DAIN, this function is set with the intelligent function module switch setting. 3) Refer to ("Analog output status combination list" in the Digital-Analog Converter Module User's Manual to check the execution status of output. 																	
Analog output test while the programmable controller CPU is in the STOP status	<p>Outputs the analog value converted from a digital value when CH□ Output enable/disable flag is forcibly turned on while the programmable controller CPU is in the STOP status.</p> <table border="1" style="width: 100%; border-collapse: collapse; text-align: center;"> <thead> <tr> <th rowspan="2">Setting combination</th> <th>D/A conversion enable/disable</th> <th colspan="2">Enable</th> <th colspan="2">Disable</th> </tr> <tr> <th>CH□ Output enable/disable flag</th> <th>Enable</th> <th>Disable</th> <th>Enable</th> <th>Disable</th> </tr> </thead> <tbody> <tr> <td>Analog output test</td> <td>Allowed</td> <td>Not allowed</td> <td>Not allowed</td> <td>Not allowed</td> <td>Not allowed</td> </tr> </tbody> </table>	Setting combination	D/A conversion enable/disable	Enable		Disable		CH□ Output enable/disable flag	Enable	Disable	Enable	Disable	Analog output test	Allowed	Not allowed	Not allowed	Not allowed	Not allowed	-	○	
Setting combination	D/A conversion enable/disable		Enable		Disable																
	CH□ Output enable/disable flag	Enable	Disable	Enable	Disable																
Analog output test	Allowed	Not allowed	Not allowed	Not allowed	Not allowed																
Resolution mode	Switches the resolution mode according to the application. The resolution can be selected from 1/4000 or 1/12000. The resolution mode is batch-set for all channels.	○	○																		
Online module replacement	Replaces a module without stopping the system.	-	○	Replaceable modules during online are the Process CPU and the Redundant CPU.																	

3.8.3 I/O signal comparison to programmable controller CPU

Sequence program change is required as the I/O signals differ.

For details of the I/O signals and sequence program, refer to the Digital-Analog Converter Module User's Manual.

A68DAI (-S1)				Q68DAIN				
Device No.	Signal name	Device No.	Signal name	Device No.	Signal name	Device No.	Signal name	
X0	Watchdog timer error flag	Y0	Not used	X0	Module READY	Y0	Not used	
X1	D/A conversion READY flag	Y1		X1	Not used	Y1	CH1 Output enable/disable flag	
X2	Error flag	Y2		X2		Y2	CH2 Output enable/disable flag	
X3	Not used	Y3		X3		Y3	CH3 Output enable/disable flag	
X4		Y4		X4		Y4	CH4 Output enable/disable flag	
X5		Y5		X5		Y5	CH5 Output enable/disable flag	
X6		Y6		X6		Y6	CH6 Output enable/disable flag	
X7		Y7		X7		Y7	CH7 Output enable/disable flag	
X8		Y8		X8		Y8	CH8 Output enable/disable flag	
X9		Y9		X9	Y9	Operating condition setting completion flag	Operating condition setting request	
XA	YA	XA		YA	Offset/gain setting mode status flag	User range write request		
XB	YB	XB		YB	Channel change completion flag	Channel change request		
XC	Not used	YC		XC	Setting value change completion flag	Setting value change request		
XD	Interlock signal for the RFRP and RTOP instructions when the A68DAI(-S1) is used in remote I/O station	YD		XD	Synchronous output mode flag	YD	Synchronous output request	
XE		YE		XE	Not used	YE	Not used	
XF		YF		XF	Error flag	YF	Error clear request	
X10	Not used	Y10		D/A conversion output enable flag				
X11		Y11						
X12		Y12						
X13		Y13						
X14		Y14						
X15		Y15						
X16		Y16						
X17		Y17						
X18		Y18	Error reset flag					
X19		Y19						
X1A	Y1A							
X1B	Y1B							
X1C	Y1C							
X1D	Interlock signal for the RFRP and RTOP instructions when the A68DAI(-S1) is used in remote I/O station	Y1D	Not used					
X1E		Y1E						
X1F		Y1F						

3.8.4 Buffer memory address comparison

Sequence program change is required as the assignment of buffer memory differs.

For details of the buffer memories and sequence program, refer to the Digital-Analog Converter Module User's Manual.

A68DAI(-S1)			Q68DAIN		
Address (decimal)	Name	Read/write	Address (decimal)	Name	Read/write
0	D/A conversion enable/disable channel	R/W	0	D/A conversion enable/disable	R/W
1	CH1 Digital value		1	CH1 Digital value	
2	CH2 Digital value		2	CH2 Digital value	
3	CH3 Digital value		3	CH3 Digital value	
4	CH4 Digital value		4	CH4 Digital value	
5	CH5 Digital value		5	CH5 Digital value	
6	CH6 Digital value		6	CH6 Digital value	
7	CH7 Digital value		7	CH7 Digital value	
8	CH8 Digital value		8	CH8 Digital value	
9	Resolution of digital value	R	9	System area (Not used)	-
10	CH1 Setting value check code		10	CH1 Setting value check code	R
11	CH2 Setting value check code		11	CH2 Setting value check code	
12	CH3 Setting value check code		12	CH3 Setting value check code	
13	CH4 Setting value check code		13	CH4 Setting value check code	
14	CH5 Setting value check code		14	CH5 Setting value check code	
15	CH6 Setting value check code		15	CH6 Setting value check code	
16	CH7 Setting value check code		16	CH7 Setting value check code	
17	CH8 Setting value check code		17	CH8 Setting value check code	
			18	CH8 Setting value check code	
			19	Error code	
			20	Setting range (CH1 to CH4)	
			21	Setting range (CH5 to CH8)	
			22	Offset/gain setting mode Offset specification	R/W
			23	Offset/gain setting mode Gain specification	
			24	Offset/gain adjusted value specification	
			25	System area (Not used)	-
			to		
			157		
			158	Mode switching setting	R/W
			159		
			160		
			to	System area (Not used)	-
			201		
			202		
			203	CH1 Industrial shipment settings offset value	R/W
			204	CH1 Industrial shipment settings gain value	
			205	CH2 Industrial shipment settings offset value	
			206	CH2 Industrial shipment settings gain value	
			207	CH3 Industrial shipment settings offset value	
			208	CH3 Industrial shipment settings gain value	
				CH4 Industrial shipment settings offset value	

Q68DAIN		
Address (decimal)	Name	Read/write
209	CH4 Industrial shipment settings gain value	R/W
210	CH5 Industrial shipment settings offset value	
211	CH5 Industrial shipment settings gain value	
212	CH6 Industrial shipment settings offset value	
213	CH6 Industrial shipment settings gain value	
214	CH7 Industrial shipment settings offset value	
215	CH7 Industrial shipment settings gain value	
216	CH8 Industrial shipment settings offset value	
217	CH8 Industrial shipment settings gain value	
218	CH1 User range settings offset value	
219	CH1 User range settings gain value	
220	CH2 User range settings offset value	
221	CH2 User range settings gain value	
222	CH3 User range settings offset value	
223	CH3 User range settings gain value	
224	CH4 User range settings offset value	
225	CH4 User range settings gain value	
226	CH5 User range settings offset value	
227	CH5 User range settings gain value	
228	CH6 User range settings offset value	
229	CH6 User range settings gain value	
230	CH7 User range settings offset value	
231	CH7 User range settings gain value	
232	CH8 User range settings offset value	
233	CH8 User range settings gain value	

3.9 A68DAV

3.9.1 Performance comparison

Item		A68DAV				
Digital input		(1)16-bit signed binary (2)Setting range:				
		Setting resolution		Setting range		
		1/4000		-4000 to 4000		
		1/8000		-8000 to 8000		
		1/12000		-12000 to 12000		
Analog output		-10 to 0 to 10VDC (External load resistance value: 2kΩ to 1MΩ)				
I/O characteristics		Digital value resolution			*Analog output value	
		1/4000	1/8000	1/12000		
		Digital input value	4000	8000	12000	+10V
			2000	4000	6000	+5V
			0	0	0	0V
			-2000	-4000	-6000	-5V
-4000	-8000	-12000	-10V			
		*When offset value 0V, gain value 10V settings				
Maximum resolution of analog value	1/4000	2.5mV				
	1/8000	1.25mV				
	1/12000	0.83mV				
Overall accuracy (accuracy at maximum analog output value)		±1.0% (±100mV)				
Conversion speed		Within 40ms/8 channels (same time for one channel) Note) Time from when the digital input is written to when the specified analog value is reached				
Absolute maximum output		-12 to +12V Note) Max. output voltage restricted by output protection circuit				
Number of analog output points		8 channels/module				
Number of writes to E ² PROM		-				
Output short protection		-				
Isolation method		Between the output terminal and programmable controller power supply: photocoupler isolation (Between channels: non-isolation)				
Dielectric withstand voltage		-				
Insulation resistance		-				
Number of occupied I/O points		32 points (I/O assignment: special 32 points)				
Connected terminal		38-point terminal block				
Applicable wire size		0.75 to 2mm ² (Applicable tightening torque: 39 to 59N•cm)				
Applicable solderless terminal		V1.25-3, V1.25-YS3A, V2-S3, V2-YS3A				
Internal current consumption (5VDC)		0.15A				

○: Compatible, △: Partial change required, ×: Incompatible

		Q68DAVN	Compatibility	Precautions for replacement																												
		16-bit signed binary (Normal resolution mode: -4096 to 4095, High resolution mode: -12288 to 12287, -16384 to 16383)	○																													
		-10 to 10VDC (External load resistance value: 1kΩ to 1MΩ)	○																													
		<table border="1"> <thead> <tr> <th colspan="2" rowspan="2">Analog output range</th> <th colspan="2">Normal resolution mode</th> <th colspan="2">High resolution mode</th> </tr> <tr> <th>Digital input value</th> <th>Maximum resolution</th> <th>Digital input value</th> <th>Maximum resolution</th> </tr> </thead> <tbody> <tr> <td rowspan="4">Voltage</td> <td>0 to 5V</td> <td rowspan="2">0 to 4000</td> <td>1.25mV</td> <td rowspan="2">0 to 12000</td> <td>0.416mV</td> </tr> <tr> <td>1 to 5V</td> <td>1.0mV</td> <td>0.333mV</td> </tr> <tr> <td>-10 to 10V</td> <td rowspan="2">-4000 to 4000</td> <td>2.5mV</td> <td>-16000 to 16000</td> <td>0.625mV</td> </tr> <tr> <td>User range settings</td> <td>0.75mV</td> <td>-12000 to 12000</td> <td>0.333mV</td> </tr> </tbody> </table>	Analog output range		Normal resolution mode		High resolution mode		Digital input value	Maximum resolution	Digital input value	Maximum resolution	Voltage	0 to 5V	0 to 4000	1.25mV	0 to 12000	0.416mV	1 to 5V	1.0mV	0.333mV	-10 to 10V	-4000 to 4000	2.5mV	-16000 to 16000	0.625mV	User range settings	0.75mV	-12000 to 12000	0.333mV	○	
Analog output range		Normal resolution mode			High resolution mode																											
		Digital input value	Maximum resolution	Digital input value	Maximum resolution																											
Voltage	0 to 5V	0 to 4000	1.25mV	0 to 12000	0.416mV																											
	1 to 5V		1.0mV		0.333mV																											
	-10 to 10V	-4000 to 4000	2.5mV	-16000 to 16000	0.625mV																											
	User range settings		0.75mV	-12000 to 12000	0.333mV																											
		Ambient temperature 25±5°C: within ±0.1% (±10mV) Ambient temperature 0 to 55°C: within ±0.3% (±30mV)	○																													
		80μs/channel	○																													
		±12V	○																													
		8 channels/module	○																													
		Max. 100,000 times	○																													
		Available	○																													
		Between the I/O terminal and programmable controller power supply: photocoupler isolation Between output channels: non-isolation Between external power supply and analog output: transformer isolation	○																													
		Between the I/O terminal and programmable controller power supply: 500VAC, for 1 minute	○																													
		Between the I/O terminal and programmable controller power supply: 500VDC, 20MΩ or more	○																													
		16 points (I/O assignment: intelligent 16 points)	△	The number of occupied I/O points has changed to 16 points.																												
		18-point terminal block	×																													
		0.3 to 0.75mm ²	×	Wiring change is required.																												
		FG terminal: R1.25-3, 1.25-YS3, RAV1.25-3, V1.25-YS3A Terminals other than FG: R1.25-3 (Sleeved solderless terminal cannot be used.)	×																													
		0.38A	△	The recalculation of internal current consumption (5VDC) is required.																												

Item		A68DAV	
External power supply	Voltage	21.6 to 26.4VDC	
	Current consumption	0.2A	
	Inrush current	-	
Weight		0.6kg	

○ : Compatible, △ : Partial change required, × : Incompatible

	Q68DAVN	Compatibility	Precautions for replacement
	24VDC +20%, -15% Ripple, spike 500mVp-p or less	○	
	0.20A		
	2.5A, 230μs or less		
	0.20kg	○	

3.9.2 Functional comparison

○ : Available, - : Not available

Item	Description	A68DAV	Q68DAVN	Precautions for replacement																	
D/A conversion enable/disable function	Specifies whether to enable or disable the D/A conversion for each channel.	○	○	On Q68DAVN, by disabling the D/A conversion for the channels that are not used, the conversion speed can be shortened.																	
D/A output enable/disable function	Specifies whether to output the D/A conversion value or the offset value for each channel. The conversion speed stays constant regardless of whether D/A output is enabled or disabled.	○	○	On Q68DAVN, the output enable/disable is set with Y signal (CH□ Output enable/disable flag).																	
Synchronous output function	Obtains analog output synchronized with the programmable controller CPU. The analog output will be updated after Synchronous output request (YD) is set to ON and the time specified as "programmable controller CPU processing time + 120μs" has elapsed. However, the analog output will be fixed to CH1, and other channels (CH2 to CH8) cannot be used. When the module is mounted on a remote I/O station, the analog output will not be synchronized because of a link scan delay if the synchronous output function is specified.	-	○																		
Analog output HOLD/CLEAR function	Retains an analog value that was output when the programmable controller CPU is in the STOP status or an error occurs.	○	○	<ol style="list-style-type: none"> 1) On Q68DAVN, the setting of HOLD/CLEAR is carried out for each channel. 2) For the Q68DAVN, this function is set with the intelligent function module switch setting. 3) Refer to ("Analog output status combination list" in the Digital-Analog Converter Module User's Manual to check the execution status of output. 																	
Analog output test while the programmable controller CPU is in the STOP status	<p>Outputs the analog value converted from a digital value when CH□ Output enable/disable flag is forcibly turned on while the programmable controller CPU is in the STOP status.</p> <table border="1"> <thead> <tr> <th rowspan="2">Setting combination</th> <th>D/A conversion enable/disable</th> <th colspan="2">Enable</th> <th colspan="2">Disable</th> </tr> <tr> <th>CH□ Output enable/disable flag</th> <th>Enable</th> <th>Disable</th> <th>Enable</th> <th>Disable</th> </tr> </thead> <tbody> <tr> <td>Analog output test</td> <td>Allowed</td> <td>Not allowed</td> <td>Not allowed</td> <td></td> <td></td> </tr> </tbody> </table>	Setting combination	D/A conversion enable/disable	Enable		Disable		CH□ Output enable/disable flag	Enable	Disable	Enable	Disable	Analog output test	Allowed	Not allowed	Not allowed			-	○	
Setting combination	D/A conversion enable/disable		Enable		Disable																
	CH□ Output enable/disable flag	Enable	Disable	Enable	Disable																
Analog output test	Allowed	Not allowed	Not allowed																		
Resolution mode	Switches the resolution mode according to the application. The resolution can be selected from 1/4000, 1/12000, or 1/16000. The resolution mode is batch-set for all channels.	○	○																		
Online module replacement	Replaces a module without stopping the system.	-	○	Replaceable modules during online are the Process CPU and the Redundant CPU.																	

3.9.3 I/O signal comparison to programmable controller CPU

Sequence program change is required as the I/O signals differ.

For details of the I/O signals and sequence program, refer to the Digital-Analog Converter Module User's Manual.

A68DAV				Q68DAVN				
Device No.	Signal name	Device No.	Signal name	Device No.	Signal name	Device No.	Signal name	
X0	Watchdog timer error flag	Y0	Not used	X0	Module READY	Y0	Not used	
X1	D/A conversion READY flag	Y1		X1	Not used	Y1	CH1 Output enable/disable flag	
X2	Error flag	Y2		X2		Y2	CH2 Output enable/disable flag	
X3	Not used	Y3		X3		Y3	CH3 Output enable/disable flag	
X4		Y4		X4		Y4	CH4 Output enable/disable flag	
X5		Y5		X5		Y5	CH5 Output enable/disable flag	
X6		Y6		X6		Y6	CH6 Output enable/disable flag	
X7		Y7		X7		Y7	CH7 Output enable/disable flag	
X8		Y8		X8		High resolution mode status flag	Y8	CH8 Output enable/disable flag
X9		Y9		X9	Operating condition setting completion flag	Y9	Operating condition setting request	
XA	YA	XA		Offset/gain setting mode status flag	YA	User range write request		
XB	YB	XB		Channel change completion flag	YB	Channel change request		
XC	Not used	YC		XC	Setting value change completion flag	YC	Setting value change request	
XD	Interlock signal for the RFRP and RTOP instructions when the A68DAV is used in remote I/O station	YD		XD	Setting value change completion flag	YD	Synchronous output request	
XE		YE		XE	Not used	YE	Not used	
XF		YF		XF	Error flag	YF	Error clear request	
X10	Not used	Y10		D/A conversion output enable flag				
X11		Y11						
X12		Y12						
X13		Y13						
X14		Y14						
X15		Y15						
X16		Y16						
X17		Y17						
X18	Y18	Error reset flag						
X19	Y19	Not used						
X1A	Y1A							
X1B	Y1B							
X1C	Y1C							
X1D	Interlock signal for the RFRP and RTOP instructions when the A68DAV is used in remote I/O station	Y1D	Not used					
X1E		Y1E						
X1F		Y1F						

3.9.4 Buffer memory address comparison

Sequence program change is required as the assignment of buffer memory differs.

For details of the buffer memories and sequence program, refer to the Digital-Analog Converter Module User's Manual.

A68DAV			Q68DAVN		
Address (decimal)	Name	Read/write	Address (decimal)	Name	Read/write
0	D/A conversion enable/disable channel	R/W	0	D/A conversion enable/disable	R/W
1	CH1 Digital value		1	CH1 Digital value	
2	CH2 Digital value		2	CH2 Digital value	
3	CH3 Digital value		3	CH3 Digital value	
4	CH4 Digital value		4	CH4 Digital value	
5	CH5 Digital value		5	CH5 Digital value	
6	CH6 Digital value		6	CH6 Digital value	
7	CH7 Digital value		7	CH7 Digital value	
8	CH8 Digital value		8	CH8 Digital value	
9	Resolution of digital value	R	9	System area (Not used)	R
10	CH1 Setting value check code		10	CH1 Setting value check code	
11	CH2 Setting value check code		11	CH2 Setting value check code	
12	CH3 Setting value check code		12	CH3 Setting value check code	
13	CH4 Setting value check code		13	CH4 Setting value check code	
14	CH5 Setting value check code		14	CH5 Setting value check code	
15	CH6 Setting value check code		15	CH6 Setting value check code	
16	CH7 Setting value check code		16	CH7 Setting value check code	
17	CH8 Setting value check code		17	CH8 Setting value check code	
			18	CH8 Setting value check code	
			19	Error code	
			20	Setting range (CH1 to CH4)	
			21	Setting range (CH5 to CH8)	
			22	Offset/gain setting mode Offset specification	R/W
			23	Offset/gain setting mode Gain specification	
			24	Offset/gain adjusted value specification	
			25	System area (Not used)	-
			to		
			157		
			158	Mode switching setting	R/W
			159		
			160	System area (Not used)	-
			to		
			201		
			202	CH1 Industrial shipment settings offset value	R/W
			203	CH1 Industrial shipment settings gain value	
			204	CH2 Industrial shipment settings offset value	
			205	CH2 Industrial shipment settings gain value	
			206	CH3 Industrial shipment settings offset value	
			207	CH3 Industrial shipment settings gain value	
			208	CH4 Industrial shipment settings offset value	

Q68DAVN		
Address (decimal)	Name	Read/write
209	CH4 Industrial shipment settings gain value	R/W
210	CH5 Industrial shipment settings offset value	
211	CH5 Industrial shipment settings gain value	
212	CH6 Industrial shipment settings offset value	
213	CH6 Industrial shipment settings gain value	
214	CH7 Industrial shipment settings offset value	
215	CH7 Industrial shipment settings gain value	
216	CH8 Industrial shipment settings offset value	
217	CH8 Industrial shipment settings gain value	
218	CH1 User range settings offset value	
219	CH1 User range settings gain value	
220	CH2 User range settings offset value	
221	CH2 User range settings gain value	
222	CH3 User range settings offset value	
223	CH3 User range settings gain value	
224	CH4 User range settings offset value	
225	CH4 User range settings gain value	
226	CH5 User range settings offset value	
227	CH5 User range settings gain value	
228	CH6 User range settings offset value	
229	CH6 User range settings gain value	
230	CH7 User range settings offset value	
231	CH7 User range settings gain value	
232	CH8 User range settings offset value	
233	CH8 User range settings gain value	

4 TEMPERATURE INPUT MODULE REPLACEMENT

4.1 List of Temperature Input Module Alternative Models for Replacement

Production discontinuation		Transition to Q series	
Product	Model	Model	Remarks (Restrictions)
Temperature input module	A616TD*1 A60MXT(N)	Q64TD	1) External wiring : Cable size is changed. 2) Number of slots : Changed (4 modules are required when one A616TD and one A60MXT(N) are used.) 3) Program : The number of occupied I/O points, I/O signals, and buffer memory addresses are changed. 4) Performance specifications change: 4CH/module 5) Functional specifications: Not changed
		Q68TD-G-H02 Q68TD-G-H01	1) External wiring : Connector wiring and cable size are changed. 2) Number of slots : Changed (2 modules are required when one A616TD and one A60MXT(N) are used.) 3) Program : The number of occupied I/O points, I/O signals, and buffer memory addresses are changed. 4) Performance specifications change: 8CH/module 5) Functional specifications: The disconnection detection function is equipped (only in the Q68TD-G-H02). Transformer isolation is provided between channels.
	A68RD3N	Q64RD	1) External wiring : Cable size is changed. 2) Number of slots: : Changed (2 modules are required.) 3) Program : The number of occupied I/O points, I/O signals, and buffer memory addresses are changed. 4) Performance specifications change: 4CH/module 5) Functional specifications: Not changed
		Q64RD-G	1) External wiring : Cable size is changed. 2) Number of slots : Changed (2 modules are required.) 3) Program : The number of occupied I/O points, I/O signals, and buffer memory addresses are changed. 4) Performance specifications change: 4CH/module 5) Functional specifications: RTD Ni100-compliant and transformer isolation is provided between channels.
		Q68RD3-G	1) External wiring : Connector wiring and cable size are changed. 2) Number of slots : Not changed 3) Program : The number of occupied I/O points, I/O signals, and buffer memory addresses are changed. 4) Performance specifications change: Resolution and conversion speed 5) Functional specifications: 32-bit output is not available. RTD Ni100-compliant and transformer isolation is provided between channels.
	A68RD4N	Q64RD	1) External wiring : Cable size is changed. 2) Number of slots : Changed (2 modules are required.) 3) Program : The number of occupied I/O points, I/O signals, and buffer memory addresses are changed. 4) Performance specifications change: 4CH/module 5) Functional specifications: Not changed
		Q64RD-G	1) External wiring : Cable size is changed. 2) Number of slots : Changed (2 modules are required.) 3) Program : The number of occupied I/O points, I/O signals, and buffer memory addresses are changed. 4) Performance specifications change: 4CH/module 5) Functional specifications: RTD Ni100-compliant and transformer isolation is provided between channels.

*1 Depending on the connected sensor and the analog input range, use each module in combination (A616TD, A60MX, A60MXR, A60MXRN, A60MXT, and A60MXTN) as shown below.
 The description in this chapter is based on the condition with "Thermocouple" connected, which is a general use.

Module combination	Thermocouple	Sensor other than thermocouple	
		0 to 10V	-10 to 10V, -20 to 20mA
A616TD + A60MXT(N)	○	○	-
A616TD + A60MXT(N) + A60MX(R/RN)	○	○	○
A616TD + A60MX(R/RN)	-	○	○
A616TD	-	○	-

4.2 A616TD (Replacement to the Q64TD)

4.2.1 Performance comparison

(1) Performance comparison list

Item		A616TD (When using the A60MXT and A60MXTN together)
Temperature sensor input		-200 to 1800°C
Output	Digital output value	16-bit signed binary (0 to 4000) (Data part: 12 bits)
	Detected temperature value	16-bit signed binary (-2000 to 18000: value up to the first decimal place × 10)
Applicable thermocouple		Refer to Section 4.2.1 (2).
Measured temperature range accuracy		Refer to Section 4.2.1 (2).
Overall accuracy		Refer to the table in Section 4.2.1 (2). Measured temperature range accuracy ±0.5°C
Maximum conversion speed		50ms/channel
Isolation method		Between the input terminal and programmable controller power supply: photocoupler isolation Between channels: non-isolation (1MΩ resistor isolation)
Number of temperature sensor input points		15 points/module (A60MXT, A60MXTN) (The A60MXT and A60MXTN can be mounted up to seven in total to one A616TD.)
Number of occupied I/O points		32 points (I/O assignment: special 32 points)
External connection system		38-point terminal block
Applicable wire size		0.75 to 2mm ² (Applicable tightening torque: 39 to 59N•cm)
Applicable solderless terminal		V1.25-3, V1.25-YS3A, V2-S3, V2-YS3A
Internal current consumption (5VDC)		1.0A
Weight		0.85kg

*1 Calculate the accuracy in the following method.

$$(\text{Accuracy}) = (\text{Conversion accuracy}) + (\text{Temperature characteristics}) \times (\text{Operating ambient temperature variation}) + (\text{Cold junction compensation accuracy})$$

An operating ambient temperature variation indicates a deviation of the operating ambient temperature from the 25±5°C range.

○ : Compatible, △ : Partial change required, × : Incompatible

	Q64TD	Compatibility	Precautions for replacement															
	-270 to 1820°C	○																
	16-bit signed binary (Scaling value)	○																
	16-bit signed binary (-2700 to 18200: value up to the first decimal place × 10)	○																
	Refer to Section 4.2.1 (2).	△	As the applicable thermocouples and thermocouple compliance standards differ, refer to Section 4.2.1 (2) to check the specifications, and use the thermocouple that can be used with the Q64TD.															
	Refer to Section 4.2.1 (2).	△	As they depend on the applicable thermocouple and measured															
	*1	○	temperature range, refer to Section 4.2.1 (2) to check the specifications.															
	40ms/channel	○																
	<table border="1"> <thead> <tr> <th>Isolated area</th> <th>Isolation method</th> <th>Dielectric withstand voltage</th> <th>Insulation resistance</th> </tr> </thead> <tbody> <tr> <td>Between thermocouple input and earth</td> <td>Transformer isolation</td> <td rowspan="2">1780VrmsAC/3 cycles (altitude 2000m)</td> <td>500VDC 100MΩ or more</td> </tr> <tr> <td>Between thermocouple input channels</td> <td>Transformer isolation</td> <td>500VDC 10MΩ or more</td> </tr> <tr> <td>Between cold junction compensation input (Pt100) and ground</td> <td>Non-isolation</td> <td>-</td> <td>-</td> </tr> </tbody> </table>	Isolated area	Isolation method	Dielectric withstand voltage	Insulation resistance	Between thermocouple input and earth	Transformer isolation	1780VrmsAC/3 cycles (altitude 2000m)	500VDC 100MΩ or more	Between thermocouple input channels	Transformer isolation	500VDC 10MΩ or more	Between cold junction compensation input (Pt100) and ground	Non-isolation	-	-	○	
Isolated area	Isolation method	Dielectric withstand voltage	Insulation resistance															
Between thermocouple input and earth	Transformer isolation	1780VrmsAC/3 cycles (altitude 2000m)	500VDC 100MΩ or more															
Between thermocouple input channels	Transformer isolation		500VDC 10MΩ or more															
Between cold junction compensation input (Pt100) and ground	Non-isolation	-	-															
	4 channels/module	×	Consider replacement with multiple Q64TD.															
	16 points (I/O assignment: intelligent 16 points)	△	The number of occupied I/O points has changed to 16 points.															
	18-point terminal block	×	Wiring change is required.															
	0.3 to 0.75mm ²	×																
	1.25-3, R1.25-3 (Sleeved solderless terminal cannot be used.)	×																
	0.50A	○																
	0.25kg	○																

(2) Applicable thermocouple and measured temperature range accuracy

A616TD								
JIS	ANSI	DIN	BS	Measurement range number	1	2	3	4
				Allowable input voltage range [mV]	-12.5 to 12.5	0 to 25	0 to 50	0 to 100
B	B	-	PtRh30-PtRh6	Measured temperature range [°C]	100 to 1500	100 to 1800	100 to 1800	100 to 1800
				Accuracy at 25°C [%]	-	±0.5	-	-
				Temperature drift [%/°C]	-	±0.013	-	-
R	R	-	PtRh13-Pt	Measured temperature range [°C]	0 to 1000	0 to 1700	0 to 1700	0 to 1700
				Accuracy at 25°C [%]	-	±0.4	-	-
				Temperature drift [%/°C]	-	±0.011	-	-
S	S	PtRh-Pt	PtRh10-Pt	Measured temperature range [°C]	0 to 1200	0 to 1700	0 to 1700	0 to 1700
				Accuracy at 25°C [%]	-	±0.4	-	-
				Temperature drift [%/°C]	-	±0.011	-	-
K	K	NiCr-Ni	NiCr-NiAl	Measured temperature range [°C]	-200 to 250	0 to 500	0 to 1000	0 to 1300
				Accuracy at 25°C [%]	±0.4	±0.3	±0.3	±0.5
				Temperature drift [%/°C]	±0.011	±0.01	±0.01	±0.013
E	E	-	NiCr-CuNi	Measured temperature range [°C]	-200 to 150	0 to 300	0 to 600	0 to 1000
				Accuracy at 25°C [%]	±0.4	±0.3	±0.3	±0.4
				Temperature drift [%/°C]	±0.011	±0.01	±0.01	±0.011
J	J	-	Fe-CuNi	Measured temperature range [°C]	-200 to 200	0 to 400	0 to 800	0 to 1200
				Accuracy at 25°C [%]	±0.4	±0.3	±0.3	±0.4
				Temperature drift [%/°C]	±0.011	±0.01	±0.01	±0.011
T	T	-	Cu-CuNi	Measured temperature range [°C]	-200 to 200	0 to 400	0 to 400	0 to 400
				Accuracy at 25°C [%]	±0.5	±0.3	-	-
				Temperature drift [%/°C]	±0.013	±0.01	-	-
-	-	Fe-CuNi	-	Measured temperature range [°C]	-100 to 200	0 to 400	0 to 800	0 to 900
				Accuracy at 25°C [%]	-	±0.3	±0.3	±0.5
				Temperature drift [%/°C]	-	±0.01	±0.01	±0.013
-	-	Cu-CuNi	-	Measured temperature range [°C]	-100 to 200	0 to 400	0 to 600	0 to 600
				Accuracy at 25°C [%]	-	±0.3	±0.4	-
				Temperature drift [%/°C]	-	±0.01	±0.011	-

Q64TD					
JIS	Specifications				
B	Measured temperature range [°C]	0 to 600	600 to 800	800 to 1700	1700 to 1820
	Conversion accuracy at 25±0.5°C [°C]	-	±3.0	±2.5	-
	Temperature characteristics [°C]		±0.4	±0.4	
R	Measured temperature range [°C]	-50 to 0	0 to 300	300 to 1600	1600 to 1760
	Conversion accuracy at 25±0.5°C [°C]	-	±2.5	±2.0	-
	Temperature characteristics [°C]		±0.4	±0.3	
S	Measured temperature range [°C]	-50 to 0	0 to 300	300 to 1600	1600 to 1760
	Conversion accuracy at 25±0.5°C [°C]	-	±2.5	±2.0	-
	Temperature characteristics [°C]		±0.4	±0.3	
K	Measured temperature range [°C]	-270 to -200	-200 to 0	0 to 1200	1200 to 1370
	Conversion accuracy at 25±0.5°C [°C]	-	Larger value of ±0.5°C, or ±0.5% of measured temperature	Larger value of ±0.5°C, or ±0.25% of measured temperature	-
	Temperature characteristics [°C]		Larger value of ±0.06°C, or ±0.2% of measured temperature	Larger value of ±0.06°C, or ±0.02% of measured temperature	
E	Measured temperature range [°C]	-270 to -200	-200 to 0	0 to 900	900 to 1000
	Conversion accuracy at 25±0.5°C [°C]	-	Larger value of ±0.5°C, or ±0.5% of measured temperature	Larger value of ±0.5°C, or ±0.25% of measured temperature	-
	Temperature characteristics [°C]		Larger value of ±0.06°C, or ±0.15% of measured temperature	Larger value of ±0.06°C, or ±0.02% of measured temperature	
J	Measured temperature range [°C]	-210 to -40	-40 to 750	750 to 1200	-
	Conversion accuracy at 25±0.5°C [°C]	-	Larger value of ±0.5°C, or ±0.25% of measured temperature	-	-
	Temperature characteristics [°C]	-	Larger value of ±0.06°C, or ±0.02% of measured temperature	-	-
T	Measured temperature range [°C]	-270 to -200	-200 to 0	0 to 350	350 to 400
	Conversion accuracy at 25±0.5°C [°C]	-	Larger value of ±0.5°C, or ±0.5% of measured temperature	Larger value of ±0.5°C, or ±0.25% of measured temperature	-
	Temperature characteristics [°C]	-	Larger value of ±0.06°C, or ±0.1% of measured temperature	Larger value of ±0.06°C, or ±0.02% of measured temperature	-
N	Measured temperature range [°C]	-270 to -200	-200 to 0	0 to 1250	1250 to 1300
	Conversion accuracy at 25±0.5°C [°C]	-	Larger value of ±0.5°C, or ±0.5% of measured temperature	Larger value of ±0.5°C, or ±0.25% of measured temperature	-
	Temperature characteristics [°C]	-	Larger value of ±0.06°C, or ±0.2% of measured temperature	Larger value of ±0.06°C, or ±0.02% of measured temperature	-

4.2.2 Functional comparison

○ : Available, - : Not available

Item	Description	A616TD	Q64TD	Precautions for replacement
Temperature conversion function	Imports temperature data.	○	○	
Conversion enable/disable function	Sets whether to enable/disable a conversion per channel.	○	○	
Disconnection detection function	Detects a disconnection of the connected thermocouple of each channel.	○	○	On Q64TD, the channel set conversion enable automatically performs the disconnection detection.
Temperature conversion value storage	Stores imported temperature data in the buffer memory.	○	○	
Input type selection function	Sets an input type for each channel.	○	○	For the Q64TD, this function is set with the intelligent function module switch setting.
Warning output function	Outputs a warning when the temperature exceeds the set temperature range.	-	○	
Temperature conversion system	Processes the detected temperature by specified method.	-	○	
Scaling function	Converts a measured temperature value into a percent value (%) in set width.	-	○	
Pt100 cold junction compensation enable/disable setting function	Sets whether the cold junction compensation using the Pt100 attached to the terminal is performed or not.	-	○	
Offset/gain setting function	Performs linear correction by individually compensating any given 2 points (offset value/gain value) within the effective range.	-	○	
Error correction function	For all input ranges, the function allows compensating the temperature measurement value by part of the compensation value the errors compensation value.	○	-	Perform the error correction by the offset/gain setting of the Q64TD.
Online module replacement	Replaces a module without stopping the system.	-	○	Replaceable modules during online are the Process CPU and the Redundant CPU.

4.2.3 I/O signal comparison to programmable controller CPU

Sequence program change is required as the I/O signals differ.

For details of the I/O signals and sequence program, refer to the Thermocouple Input Module/Channel Isolated Thermocouple/Micro Voltage Input Module User's Manual.

A616TD				Q64TD			
Device No.	Signal name	Device No.	Signal name	Device No.	Signal name	Device No.	Signal name
X0	Watchdog timer error	Y0	Not used	X0	Module READY	Y0	Not used
X1	A/D conversion READY	Y1		X1	CH1 Offset/gain setting status signal	Y1	CH1 Offset setting request
X2	Error flag	Y2		X2	CH2 Offset/gain setting status signal	Y2	CH1 Gain setting request
X3	Disconnection error detection	Y3		X3	CH3 Offset/gain setting status signal	Y3	CH2 Offset setting request
X4	Digital output value out-of-range detection	Y4		X4	CH4 Offset/gain setting status signal	Y4	CH2 Gain setting request
X5	Detected temperature value out-of-range detection	Y5		X5	Not used	Y5	CH3 Offset setting request
X6	Not used	Y6		X6		Y6	CH3 Gain setting request
X7		Y7		X7		Y7	CH4 Offset setting request
X8		Y8		X8		Y8	CH4 Gain setting request
X9		Y9		X9	Operating condition setting completion signal	Y9	Operating condition setting request
XA		YA	XA	Offset/gain setting mode status flag	YA	User range write request	
XB		YB	XB	Not used	YB	Not used	
XC	YC	XC	Disconnection detection signal	YC			
XD	YD	XD	Interlock signal for the RFRP and RTOP instructions when the A616TD is used in remote I/O station	YD	Warning output signal		
XE	YE	XE	Not used	YE	Conversion completion flag		
XF	YF	XF		Error flag	YF	Error clear request	
X10	Not used	Y10	Detected temperature value LED display request signal				
X11		Y11	Not used				
X12		Y12					
X13		Y13					
X14		Y14					
X15		Y15					
X16		Y16					
X17		Y17					
X18		Y18					
X19		Y19					
X1A	Y1A	Not used					
X1B	Y1B						
X1C	Y1C						
X1D	Y1D	Not used					
X1E	Y1E						
X1F	Y1F						

4.2.4 Buffer memory address comparison

Sequence program change is required as the assignment of buffer memory differs.

For details of buffer memories and sequence programs, refer to the Thermocouple Input Module/ Channel Isolated Thermocouple/Micro Voltage Input Module User's Manual.

A616TD			Q64TD		
Address (hex)	Name	Read/write	Address (hex)	Name	Read/write
00	Data format selection	R/W	00	Conversion enable/disable setting	R/W
01	Error code storage		01	CH1 Time/count averaging setting	
02	Error occurrence A60MX□CONNECT No. storage		02	CH2 Time/count averaging setting	
03	Thermocouple type setting error channel number storage		03	CH3 Time/count averaging setting	
04	Current sampling period storage	R	04	CH4 Time/count averaging setting	
05 to 0E	System area (Not used)	-	05 to 08	System area (Not used)	-
0F	Conversion enable/disable specification	R/W	09	Averaging processing selection	R/W
10 to 17			Multiplexer module	0A	Conversion completion flag
18	Setting data set request	-	0B	CH1 Measured temperature value	
19 to 1F	System area (Not used)	-	0C	CH2 Measured temperature value	
20 to 27	Disconnection detection enable/disable specification	R/W	0D	CH3 Measured temperature value	
28 to 2F	System area (Not used)	-	0E	CH4 Measured temperature value	
30 to 3F	Digital output value temperature setting	R/W	0F to 12	System area (Not used)	-
40 to 47	Disconnection detection channel number storage		13	Error code	R
48 to 4F	System area (Not used)	-	14	Setting range	
50 to 57	Digital output value out-of-range Channel number storage	R/W	15 to 2E	System area (Not used)	-
58 to 5F	System area (Not used)	-	2F	Warning output enable/disable setting	R/W
60 to 67	Detected temperature value out-of-range Channel number storage	R/W	30	Warning output flag	R
68 to 6F	System area (Not used)	-	31	Disconnection detection flag	
70 to 7F	INPUT channel Digital output value storage	R	32	CH1 Scaling value	
80 to FF	Error correction value setting	R/W	33	CH2 Scaling value	
100 to 17F	Thermocouple type setting	R	34	CH3 Scaling value	
180 to 1FF	MX CH.channel Digital output value storage		35	CH4 Scaling value	
200 to 27F	MX CH.channel Detected temperature value storage		36 to 3D	System area (Not used)	R/W
			3E	CH1 Scaling range lower limit value	
		3F	CH1 Scaling range upper limit value		
		40	CH2 Scaling range lower limit value		
		41	CH2 Scaling range upper limit value	R/W	
		42	CH3 Scaling range lower limit value		
		43	CH3 Scaling range upper limit value		
		44	CH4 Scaling range lower limit value		
		45	CH4 Scaling range upper limit value		
		46 to 4D	System area (Not used)	-	
		4E	CH1 Scaling width lower limit value	R/W	
		4F	CH1 Scaling width upper limit value		
		50	CH2 Scaling width lower limit value		
		51	CH2 Scaling width upper limit value		
		52	CH3 Scaling width lower limit value		
		53	CH3 Scaling width upper limit value		
		54	CH4 Scaling width lower limit value		
		55	CH4 Scaling width upper limit value		
		56	CH1 Warning output lower/lower limit value		
		57	CH1 Warning output lower/upper limit value		

Q64TD		
Address (hex)	Name	Read/write
58	CH1 Warning output upper/lower limit value	R/W
59	CH1 Warning output upper/upper limit value	
5A	CH2 Warning output lower/lower limit value	
5B	CH2 Warning output lower/upper limit value	
5C	CH2 Warning output upper/lower limit value	
5D	CH2 Warning output upper/upper limit value	
5E	CH3 Warning output lower/lower limit value	
5F	CH3 Warning output lower/upper limit value	
60	CH3 Warning output upper/lower limit value	
61	CH3 Warning output upper/upper limit value	
62	CH4 Warning output lower/lower limit value	
63	CH4 Warning output lower/upper limit value	
64	CH4 Warning output upper/lower limit value	
65	CH4 Warning output upper/upper limit value	
66 to 75	System area (Not used)	-
76	CH1 Offset temperature setting value	R/W
77	CH1 Gain temperature setting value	
78	CH2 Offset temperature setting value	
79	CH2 Gain temperature setting value	
7A	CH3 Offset temperature setting value	
7B	CH3 Gain temperature setting value	
7C	CH4 Offset temperature setting value	
7D	CH4 Gain temperature setting value	
7E to 9D	System area (Not used)	-
9E to 9F	Mode switching setting	R/W
A0	CH1 Factory default offset value	
A1	CH1 Factory default gain value	
A2	CH1 User range settings offset value	
A3	CH1 User range settings gain value	
A4	CH1 User range settings thermal (L)	
A5	EMF offset value (H)	
A6	CH1 User range settings thermal (L)	
A7	EMF gain value (H)	
A8	CH2 Factory default offset value	
A9	CH2 Factory default gain value	
AA	CH2 User range settings offset value	
AB	CH2 User range settings gain value	
AC	CH2 User range settings thermal (L)	
AD	EMF offset value (H)	
AE	CH2 User range settings thermal (L)	
AF	EMF gain value (H)	
B0	CH3 Factory default offset value	
B1	CH3 Factory default gain value	

Q64TD		
Address (hex)	Name	Read/write
B2	CH3 User range settings offset value	R/W
B3	CH3 User range settings gain value	
B4	CH3 User range settings thermal(L)	
B5	EMF offset value(H)	
B6	CH3 User range settings thermal(L)	
B7	EMF gain value(H)	
B8	CH4 Factory default offset value	
B9	CH4 Factory default gain value	
BA	CH4 User range settings offset value	
BB	CH4 User range settings gain value	
BC	CH4 User range settings thermal(L)	
BD	EMF offset value(H)	
BE	CH4 User range settings thermal(L)	
BF	EMF gain value(H)	
C0 to	System area (Not used)	

4.3 A616TD (Replacement to the Q68TD-G-H02, Q68TD-G-H01)

4.3.1 Performance comparison

(1) Performance comparison list

Item		A616TD (When using the A60MXT and A60MXTN together)
Temperature sensor input		-200 to 1800°C
Output	Digital output value	16-bit signed binary (0 to 4000) (Data part: 12 bits)
	Detected temperature value	16-bit signed binary (-2000 to 18000: value up to the first decimal place × 10)
Applicable thermocouple		Refer to Section 4.3.1 (2).
Measured temperature range accuracy		Refer to Section 4.3.1 (2).
Overall accuracy		Refer to the table in Section 4.3.1 (2). Measured temperature range accuracy ±0.5°C
Maximum conversion speed		50ms/channel
Isolation method		Between the input terminal and programmable controller power supply: photocoupler isolation Between channels: non-isolation (1MΩ resistor isolation)
Disconnection detection		Available
Number of temperature sensor input points		15 points/module (A60MXT, A60MXTN) (The A60MXT and A60MXTN can be mounted up to seven in total to one A616TD.)
Number of occupied I/O points		32 points (I/O assignment: special 32 points)
External connection system		38-point terminal block
External device connector (sold separately)		-
Applicable wire size		0.75 to 2mm ² (Applicable tightening torque: 39 to 59N•cm)
Applicable solderless terminal		V1.25-3, V1.25-YS3A, V2-S3, V2-YS3A
Internal current consumption (5VDC)		1.0A
Weight		0.85kg

○ : Compatible, △ : Partial change required, × : Incompatible

Q series		Compatibility	Precautions for replacement															
Q68TD-G-H02	Q68TD-G-H01*1																	
-270 to 1820°C		○																
16-bit signed binary (Scaling value)		○																
16-bit signed binary (-2700 to 18200: value up to the first decimal place × 10)		○																
Refer to Section 4.3.1 (2).		△	As they depend on the applicable thermocouple and thermocouple standard, refer to Section 4.3.1 (2) and check the specifications. Use the thermocouple that can be used on the Q68TD-G-H02/H01.															
Refer to Section 4.3.1 (2).		△	As they depend on the applicable thermocouple and measured															
*2		○	temperature range, refer to Section 4.3.1 (2) to check the specifications.															
640ms/8 channels*3	320ms/8 channels*3	○																
<table border="1"> <thead> <tr> <th>Isolated area</th> <th>Isolation method</th> <th>Dielectric withstand voltage</th> <th>Insulation resistance</th> </tr> </thead> <tbody> <tr> <td>Between thermocouple input and programmable controller power supply</td> <td>Transformer isolation</td> <td>AC500Vms/1min</td> <td rowspan="2">DC500V 10MΩ or more</td> </tr> <tr> <td>Between thermocouple input channels</td> <td>Transformer isolation</td> <td>AC1000Vrms/1min</td> </tr> <tr> <td>Between cold junction compensation input (Pt100) and programmable controller power supply</td> <td>Non-isolation</td> <td>-</td> <td>-</td> </tr> </tbody> </table>		Isolated area	Isolation method	Dielectric withstand voltage	Insulation resistance	Between thermocouple input and programmable controller power supply	Transformer isolation	AC500Vms/1min	DC500V 10MΩ or more	Between thermocouple input channels	Transformer isolation	AC1000Vrms/1min	Between cold junction compensation input (Pt100) and programmable controller power supply	Non-isolation	-	-	○	
Isolated area	Isolation method	Dielectric withstand voltage	Insulation resistance															
Between thermocouple input and programmable controller power supply	Transformer isolation	AC500Vms/1min	DC500V 10MΩ or more															
Between thermocouple input channels	Transformer isolation	AC1000Vrms/1min																
Between cold junction compensation input (Pt100) and programmable controller power supply	Non-isolation	-	-															
Available (all the channels are independent)	Not available	×	The Q68TD-G-H01 has the disconnection monitor function.															
8 channels + channels connected to Pt100/module		×	Consider replacement with multiple Q68TD-G-H02/H01.															
16 points (I/O assignment: intelligent 16 points)		△	The number of occupied I/O points has changed to 16 points.															
40-pin connector		×	Wiring change is required.															
A6CON4		×																
0.3mm ² (22 AWG) or less		×																
-		×																
0.65A	0.49A	○																
0.22kg	0.18kg	○																

- *1 Restrictions on mountable slot position apply to the Q68TD-G-H01.
For details, refer to the user's manual for the Q68TD-G-H01/H02.
- *2 Calculate the accuracy in the following method.
(Accuracy) = (Conversion accuracy) + (Temperature characteristics) × (Operating ambient temperature variation)
+ (Cold junction compensation accuracy)
An operating ambient temperature variation indicates a deviation of the operating ambient temperature from the 25±5°C range.
- *3 A measured temperature value is stored in the buffer memory at every 320ms/640ms, regardless of the number of conversion enable channels.

(2) Applicable thermocouple and measured temperature range accuracy

A616TD								
JIS	ANSI	DIN	BS	Measurement range number	1	2	3	4
				Allowable input voltage range [mV]	-12.5 to 12.5	0 to 25	0 to 50	0 to 100
B	B	-	PtRh30-PtRh6	Measured temperature range [°C]	100 to 1500	100 to 1800	100 to 1800	100 to 1800
				Accuracy at 25°C [%]	-	±0.5	-	-
				Temperature drift [%/°C]	-	±0.013	-	-
R	R	-	PtRh13-Pt	Measured temperature range [°C]	0 to 1000	0 to 1700	0 to 1700	0 to 1700
				Accuracy at 25°C [%]	-	±0.4	-	-
				Temperature drift [%/°C]	-	±0.011	-	-
S	S	PtRh-Pt	PtRh10-Pt	Measured temperature range [°C]	0 to 1200	0 to 1700	0 to 1700	0 to 1700
				Accuracy at 25°C [%]	-	±0.4	-	-
				Temperature drift [%/°C]	-	±0.011	-	-
K	K	NiCr-Ni	NiCr-NiAl	Measured temperature range [°C]	-200 to 250	0 to 500	0 to 1000	0 to 1300
				Accuracy at 25°C [%]	±0.4	±0.3	±0.3	±0.5
				Temperature drift [%/°C]	±0.011	±0.01	±0.01	±0.013
E	E	-	NiCr-CuNi	Measured temperature range [°C]	-200 to 150	0 to 300	0 to 600	0 to 1000
				Accuracy at 25°C [%]	±0.4	±0.3	±0.3	±0.4
				Temperature drift [%/°C]	±0.011	±0.01	±0.01	±0.011
J	J	-	Fe-CuNi	Measured temperature range [°C]	-200 to 200	0 to 400	0 to 800	0 to 1200
				Accuracy at 25°C [%]	±0.4	±0.3	±0.3	±0.4
				Temperature drift [%/°C]	±0.011	±0.01	±0.01	±0.011
T	T	-	Cu-CuNi	Measured temperature range [°C]	-200 to 200	0 to 400	0 to 400	0 to 400
				Accuracy at 25°C [%]	±0.5	±0.3	-	-
				Temperature drift [%/°C]	±0.013	±0.01	-	-
-	-	Fe-CuNi	-	Measured temperature range [°C]	-100 to 200	0 to 400	0 to 800	0 to 900
				Accuracy at 25°C [%]	-	±0.3	±0.3	±0.5
				Temperature drift [%/°C]	-	±0.01	±0.01	±0.013
-	-	Cu-CuNi	-	Measured temperature range [°C]	-100 to 200	0 to 400	0 to 600	0 to 600
				Accuracy at 25°C [%]	-	±0.3	±0.4	-
				Temperature drift [%/°C]	-	±0.01	±0.011	-

Q68TD-G-H02, Q68TD-G-H01				
Applicable thermocouple type	Measured temperature range*1	Conversion accuracy (at operating ambient temperature 25±5°C)	Temperature characteristics (per operating ambient temperature variation of 1°C)	Maximum temperature error at ambient temperature of 55°C
B	0 to 600°C	-----*3	-----*3	-----*3
	600 to 800°C*2	±3.0°C	±0.4°C	±13.0°C
	800 to 1700°C*2	±2.5°C		±12.5°C
	1700 to 1820°C	-----*3	-----*3	-----*3
R	-50 to 0°C	-----*3	-----*3	-----*3
	0 to 300°C*2	±2.5°C	±0.4°C	±12.5°C
	300 to 1600°C*2	±2.0°C	±0.3°C	±9.5°C
	1600 to 1760°C	-----*3	-----*3	-----*3
S	-50 to 0°C	-----*3	-----*3	-----*3
	0 to 300°C*2	±2.5°C	±0.4°C	±12.5°C
	300 to 1600°C*2	±2.0°C	±0.3°C	±9.5°C
	1600 to 1760°C	-----*3	-----*3	-----*3
K	-270 to -200°C	-----*3	-----*3	-----*3
	-200 to 0°C*2	Larger value of ±0.5°C or ±0.5% of measured temperature	Larger value of ±0.06°C or ±0.2% of measured temperature	±11.0°C
	0 to 1200°C*2	Larger value of ±0.5°C or ±0.25% of measured temperature	Larger value of ±0.06°C or ±0.02% of measured temperature	±9.0°C
	1200 to 1370°C	-----*3	-----*3	-----*3
E	-270 to -200°C	-----*3	-----*3	-----*3
	-200 to 0°C*2	Larger value of ±0.5°C or ±0.5% of measured temperature	Larger value of ±0.06°C or ±0.15% of measured temperature	±8.5°C
	0 to 900°C*2	Larger value of ±0.5°C or ±0.25% of measured temperature	Larger value of ±0.06°C or ±0.02% of measured temperature	±6.75°C
	900 to 1000°C	-----*3	-----*3	-----*3
J	-210 to -40°C	-----*3	-----*3	-----*3
	-40 to 750°C*2	Larger value of ±0.5°C or ±0.25% of measured temperature	Larger value of ±0.06°C or ±0.02% of measured temperature	±5.625°C
	750 to 1200°C	-----*3	-----*3	-----*3
T	-270 to -200°C	-----*3	-----*3	-----*3
	-200 to 0°C*2	Larger value of ±0.5°C or ±0.5% of measured temperature	Larger value of ±0.06°C or ±0.1% of measured temperature	±6.0°C
	0 to 350°C*2	Larger value of ±0.5°C or ±0.25% of measured temperature	Larger value of ±0.06°C or ±0.02% of measured temperature	±2.625°C
	350 to 400°C	-----*3	-----*3	-----*3
N	-270 to -200°C	-----*3	-----*3	-----*3
	-200 to 0°C*2	Larger value of ±0.5°C or ±0.5% of measured temperature	Larger value of ±0.06°C or ±0.2% of measured temperature	±11.0°C
	0 to 1250°C*2	Larger value of ±0.5°C or ±0.25% of measured temperature	Larger value of ±0.06°C or ±0.02% of measured temperature	±9.375°C
	1250 to 1300°C	-----*3	-----*3	-----*3

- *1 If a value entered from the thermocouple is outside the measured temperature range given in the table, it is handled as the maximum/minimum value of the measured temperature range.
- *2 The accuracy only in the temperature ranges of Class 1 to 3 (shaded areas) in JIS C1602-1995 apply. Also, a warm-up (power distribution) period of 30 minutes is required to satisfy with the accuracy.
- *3 A temperature can be measured; however, the accuracy is not guaranteed.

4.3.2 Functional comparison

○ : Available, △ : Partial change required, - : Not available

Item	Description	A616TD	Q68TD-G-H02/H01	Precautions for replacement
Temperature conversion function	Imports temperature data.	○	○	
Conversion enable/disable function	Sets whether to enable/disable a conversion per channel.	○	○	
Disconnection detection function	Detects a disconnection of the connected thermocouple of each channel.	○	△	The Q68TD-G-H01 does not have the disconnection detection function. Use the disconnection monitor function instead.
Temperature conversion value storage	Stores imported temperature data in the buffer memory.	○	○	
Input type selection function	Sets an input type for each channel.	○	○	For the Q68TD-G-H02/H01, this function is set with the intelligent function module switch setting.
Warning output function	Outputs a warning when the temperature exceeds the set temperature range.	-	○	
Temperature conversion system	Processes the detected temperature by specified method.	-	○	
Scaling function	Converts a measured temperature value into a percent value (%) in set width.	-	○	
Pt100 cold junction compensation enable/disable setting function	Sets whether the cold junction compensation using the Pt100 attached to the terminal is performed or not.	-	○	
Offset/gain setting function	Performs linear correction by individually compensating any given 2 points (offset value/gain value) within the effective range.	-	○	
Error correction function	For all input ranges, the function allows compensating the temperature measurement value by part of the compensation value the errors compensation value.	○	-	Perform the error correction by the offset/gain setting of the Q68TD-G-H02/H01.
Online module replacement	Replaces a module without stopping the system.	-	○	Replaceable modules during online are the Process CPU and the Redundant CPU.

4.3.3 I/O signal comparison to programmable controller CPU

Sequence program change is required as the I/O signals differ.

For details of the I/O signals and sequence program, refer to the Thermocouple Input Module/Channel Isolated Thermocouple/Micro Voltage Input Module User's Manual.

A616TD				Q68TD-G-H02, Q68TD-G-H01			
Device No.	Signal name	Device No.	Signal name	Device No.	Signal name	Device No.	Signal name
X0	Watchdog timer error	Y0	Not used	X0	Module READY	Y0	Not used
X1	A/D conversion READY	Y1		X1	Not used	Y1	
X2	Error flag	Y2		X2		Y2	
X3	Disconnection error detection	Y3		X3		Y3	
X4	Digital output value out-of-range detection	Y4		X4		Y4	
X5	Detected temperature value out-of-range detection	Y5		X5		Y5	
X6	Not used	Y6		X6		Y6	
X7		Y7		X7		Y7	
X8		Y8		X8		Y8	
X9		Y9		X9	Operating condition setting completion flag	Y9	Operating condition setting request
XA		YA		XA	Offset/gain setting mode status flag	YA	User range write request
XB		YB		XB	Channel change completion flag	YB	Channel change request
XC		YC		XC	Q68TD-G-H02: Disconnection detection signal Q68TD-G-H01: Disconnection status monitor signal	YC	Not used
XD	YD	XD		Warning output signal	YD		
XE	YE	XE		Conversion completion flag	YE		
XF	YF	XF		Error flag	YF	Error clear request	
X10	Y10	Y10	Detected temperature value LED display request signal				
X11	Y11	Y11	Not used				
X12	Y12	Y12					
X13	Y13	Y13					
X14	Y14	Y14					
X15	Y15	Y15					
X16	Y16	Y16					
X17	Y17	Y17					
X18	Y18	Y18					
X19	Y19	Y19					
X1A	Y1A	Y1A					
X1B	Y1B	Y1B					
X1C	Y1C	Y1C					
X1D	Y1D	Y1D	Interlock signal for the RFRP and RTOP instructions when the A616TD is used in remote I/O station				
X1E	Y1E	Y1E					
X1F	Y1F	Y1F					

4.3.4 Buffer memory address comparison

Sequence program change is required as the assignment of buffer memory differs.

For details of buffer memories and sequence programs, refer to the Thermocouple Input Module/ Channel Isolated Thermocouple/Micro Voltage Input Module User's Manual.

A616TD			Q68TD-G-H02, Q68TD-G-H01		
Address (hex)	Name	Read/write	Address (hex)	Name	Read/write
00	Data format selection	R/W	00	Conversion enable/disable setting	R/W
01	Error code storage		01 to 08	CH1 to CH8 Time/count/moving average/ time constant setting	
02	Error occurrence A60MX□CONNECT No. storage		09	System area (Not used)	-
03	Thermocouple type setting error channel number storage	R	0A	Conversion completion flag	R
04	Current sampling period storage		0B to 12	CH1 to CH8 Measured temperature value	
05 to 0E	System area (Not used)	-	13	Error code	
0F	Conversion enable/disable specification	R/W	14 to 15	CH1 to CH8 Setting range (Thermocouple type)	
10 to 17			A616TD Multiplexer module	16	Setting range (Offset/gain setting)
18	Setting data set request	-	17	System area (Not used)	-
19 to 1F	System area (Not used)		18 to 19	CH1 to CH8 Averaging processing selection	R/W
20 to 27	Disconnection detection enable/disable specification	R/W	1A	Offset/gain setting mode (Offset specification)	
28 to 2F	System area (Not used)	-	1B	Offset/gain setting mode (Gain specification)	
30 to 3F	Digital output value temperature setting	R/W	1C	CH1 Offset temperature setting value	
40 to 47	Disconnection detection channel number storage		1D	CH1 Gain temperature setting value	
48 to 4F	System area (Not used)	-	to		
50 to 57	Digital output value out-of-range	R/W	2B	CH8 Gain temperature setting value	R/W
	Channel number storage		2C	System area (Not used)	-
58 to 5F	System area (Not used)	-	2D	Q68TD-G-H02:Cold junction compensation setting state	R
				Q68TD-G-H01: System area	-
60 to 67	Detected temperature value out-of-range Channel number storage	R/W	2E	Warning output enable/disable setting	R/W
			2F	Warning output flag (Process alarm)	R
68 to 6F	System area (Not used)	-	30	Warning output flag (Rate alarm)	
70 to 7F	INPUT channel Digital output value storage	R	31	Q68TD-G-H02:Disconnection detection flag	R
				Q68TD-G-H01:Disconnection status monitor flag	
			32 to 39	CH1 to CH8 Scaling value	R/W
80 to FF	Error correction value setting	R/W	3A	Scaling valid/invalid setting	
100 to 17F	Thermocouple type setting	R	3B to 3D	System area (Not used)	-
180 to 1FF	MX CH.channel Digital output value storage		3E	CH1 Scaling range lower limit value	R/W
200 to 27F	MX CH.channel Detected temperature value storage	R	3F	CH1 Scaling range upper limit value	R/W
				to	
			4D	CH8 Scaling range upper limit value	R/W
			4E	CH1 Scaling width lower limit value	
			4F	CH1 Scaling width upper limit value	
			to		
			5D	CH8 Scaling width upper limit value	R/W
			5E	CH1 Process alarm lower/lower limit value	
			5F	CH1 Process alarm lower/upper limit value	
			60	CH1 Process alarm upper/lower limit value	

Q68TD-G-H02, Q68TD-G-H01		
Address (hex)	Name	Read/write
61	CH1 Process alarm upper/upper limit value	R/W
to		
7D	CH8 Process alarm upper/upper limit value	R/W
7E to 85	CH1 to CH8 Rate alarm warning detection period	
86	CH1 Rate alarm upper limit value	
87	CH1 Rate alarm lower limit value	
to		
95	CH8 Rate alarm lower limit value	R/W
96 to 9D	System area	-
9E to 9F	Mode switching setting	R/W
A0 to A3	System area (Not used)	-
A4 to A5	Q68TD-G-H02:Conversion setting for disconnection detection	R/W
	Q68TD-G-H01:Disconnection state conversion setting	
A6 to AD	Q68TD-G-H02:Conversion setting value for disconnection detection	
	Q68TD-G-H01:Conversion setting value for disconnection state	
AE to BD	System area (Not used)	-
BE	CH1 Factory default offset value	R/W
BF	CH1 Factory default gain value	
C0	CH1 User range settings offset value	
C1	CH1 User range settings gain value	
C2	CH1 User range settings thermal EMF offset value (L)	
C3	CH1 User range settings thermal EMF offset value (H)	
C4	CH1 User range settings thermal EMF gain value (L)	
C5	CH1 User range settings thermal EMF gain value (H)	
to		
FC	CH8 User range settings thermal EMF gain value (L)	R/W
FD	CH8 User range settings thermal EMF gain value (H)	

4.4 A68RD3N (Replacement to the Q64RD)

4.4.1 Performance comparison

Item		A68RD3N
Measuring method		3-wire type
Output (temperature conversion value)		16-bit signed binary -1800 to 6000 Value up to the first decimal place × 10 32-bit signed binary -180000 to 600000 Value up to the third decimal place × 1000
Applicable platinum RTD		Pt100 (JIS C1604-1997, IEC 751-am2, JIS C1604-1989, DIN 43760-1980) JPt100 (JIS C1604-1981)
Measured temperature range	Pt100	-180 to 600°C (27.10 to 313.71Ω)
	JPt100	-180 to 600°C (25.80 to 317.28Ω)
Accuracy		±1% (accuracy at full scale)
Resolution		0.025°C
Conversion speed		40ms/channel
Number of analog input points		8 channels/module
Output current for temperature detection		1mA
Isolation method		Between platinum RTD input and programmable controller power supply: photocoupler isolation Between platinum RTD input and channel: non-isolation
Dielectric withstand voltage		Between platinum RTD input and programmable controller power supply: 500VAC, for 1 minute
Disconnection detection		Detected per channel
Number of occupied I/O points		32 points (I/O assignment: special 32 points)
External connection system		38-point terminal block
Applicable wire size		0.75 to 2mm ²
Applicable solderless terminal		V1.25-3, V1.25-YS3A, V2-S3, V2-YS3A

○: Compatible, △: Partial change required, ×: Incompatible

	Q64RD	Compatibility	Precautions for replacement											
	3/4-wire type	○												
	16-bit signed binary -2000 to 8500 Value up to the first decimal place × 10 32-bit signed binary -200000 to 850000 Value up to the third decimal place × 1000	○												
	Pt100 (JIS C 1604-1997, IEC751 1983) JPt100 (JIS C 1604-1981)	△	As the compliance standards for the applicable platinum RTD differ, change the platinum RTD to the one that can be used with the Q64RD.											
	-200 to 850°C	○												
	-180 to 600°C													
	Ambient temperature 0 to 55°C: ±0.25% (accuracy relative to maximum value) Ambient temperature 25±5°C: ±0.08% (accuracy relative to maximum value)	○												
	0.025°C	○												
	40ms/channel	○												
	4 channels/module	△	Consider replacement with multiple Q64RD.											
	1mA	○												
	<table border="1"> <thead> <tr> <th>Isolated area</th> <th>Isolation method</th> <th>Dielectric withstand voltage</th> <th>Insulation resistance</th> </tr> </thead> <tbody> <tr> <td>Between platinum RTD input and programmable controller power supply</td> <td>Photocoupler isolation</td> <td>1780VrmsAC/3 cycles (altitude 2000m)</td> <td rowspan="2">10MΩ or more using 500VDC insulation resistance tester</td> </tr> <tr> <td>Between platinum RTD input and channel</td> <td>Non-isolation</td> <td>-</td> </tr> </tbody> </table>	Isolated area	Isolation method	Dielectric withstand voltage	Insulation resistance	Between platinum RTD input and programmable controller power supply	Photocoupler isolation	1780VrmsAC/3 cycles (altitude 2000m)	10MΩ or more using 500VDC insulation resistance tester	Between platinum RTD input and channel	Non-isolation	-	○	
Isolated area	Isolation method	Dielectric withstand voltage	Insulation resistance											
Between platinum RTD input and programmable controller power supply	Photocoupler isolation	1780VrmsAC/3 cycles (altitude 2000m)	10MΩ or more using 500VDC insulation resistance tester											
Between platinum RTD input and channel	Non-isolation	-												
	Detected per channel	○												
	16 points (I/O assignment: intelligent 16 points)	△	The number of occupied I/O points has changed to 16 points.											
	18-point terminal block	×	Wiring change is required.											
	0.3 to 0.75mm ²	×												
	1.25-3, R1.25-3 (Sleeved solderless terminal cannot be used.)	×												

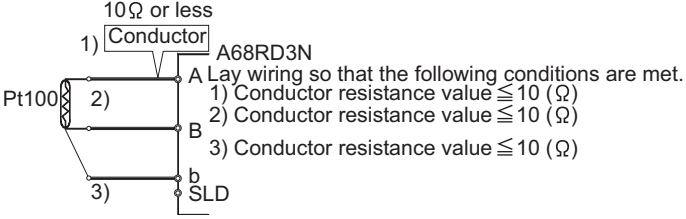
Item	A68RD3N	
Cables between module and platinum RTD	<p>Make sure that the conductor resistance value between the Pt100 and A68RD3N is 10Ω or less per conductor. All channels become the same specifications.</p> 	
Internal current consumption (5VDC)	0.94A	
Weight	0.43kg	

○ : Compatible, △ : Partial change required, × : Incompatible

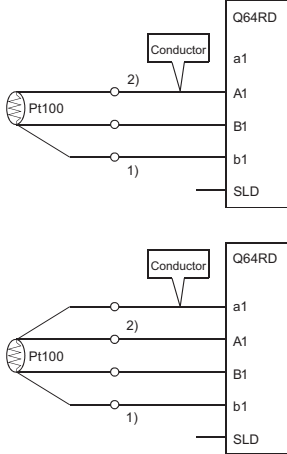
Q64RD	Compatibility	Precautions for replacement
<p>The conductor resistance value must meet the condition of $1) + 2) \leq 2k\Omega$ or less. (In the case of 3-conductor type, the difference between 1) and 2) in the conductor resistance value must be 10Ω or less.)</p> 	○	
0.60A	○	
0.17kg	○	

4.4.2 Functional comparison

○ : Available, - : Not available

Item	Description	A68RD3N	Q64RD	Precautions for replacement
Conversion enable/disable specification of each channel	Enables/disables a detection of temperature.	○	○	
Sampling/averaging processing selection	Processes the detected temperature by specified method.	○	○	The setting ranges of time and count averages differ. Refer to the RTD Input Module/ Channel Isolated RTD Input Module User's Manual to check the specifications.
Detected temperature value storage	Stores temperature data in the buffer memory.	○	○	
Disconnection detection	Detects a disconnection of connected platinum RTD or a cable.	○	○	
Specification of platinum RTD type	Specifies a platinum RTD type used.	○	○	
Range switching function	Switches the measured temperature range.	-	○	
Warning output function	Outputs a warning when the temperature exceeds the set temperature range.	-	○	
Scaling function	Converts a measured temperature value into a percent value (%) in set width.	-	○	
Error correction function	Corrects an error in temperature conversion value.	○	○	Perform the error correction by the offset/gain setting of the Q64RD.
Online module replacement	Replaces a module without stopping the system.	-	○	Replaceable modules during online are the Process CPU and the Redundant CPU.

4.4.3 I/O signal comparison to programmable controller CPU

Sequence program change is required as the I/O signals differ.

For details of the I/O signals and sequence program, refer to the RTD Input Module/Channel Isolated RTD Input Module User's Manual.

A68RD3N				Q64RD				
Device No.	Signal name	Device No.	Signal name	Device No.	Signal name	Device No.	Signal name	
X0	Watchdog timer error flag	Y0	Not used	X0	Module READY	Y0	Not used	
X1	READY flag	Y1		X1	CH1 Offset/gain setting status signal	Y1	CH1 Offset setting request	
X2	Write data error flag	Y2		X2	CH2 Offset/gain setting status signal	Y2	CH1 Gain setting request	
X3	CH1: Disconnection detection flag	Y3		X3	CH3 Offset/gain setting status signal	Y3	CH2 Offset setting request	
X4	CH2: Disconnection detection flag	Y4		X4	CH4 Offset/gain setting status signal	Y4	CH2 Gain setting request	
X5	CH3: Disconnection detection flag	Y5		Not used	X5	Not used	Y5	CH3 Offset setting request
X6	CH4: Disconnection detection flag	Y6			Y6		CH3 Gain setting request	
X7	CH5: Disconnection detection flag	Y7			Y7		CH4 Offset setting request	
X8	CH6: Disconnection detection flag	Y8			Y8		CH4 Gain setting request	
X9	CH7: Disconnection detection flag	Y9		X9	Operating condition setting completion signal	Y9	Operating condition setting request	
XA	CH8: Disconnection detection flag	YA	XA	Offset/gain setting mode status flag	YA	User range write request		
XB	Not used	YB	XB	Not used	YB	Not used		
XC		YC	XC	Disconnection detection signal	YC			
XD		YD	XD	Warning output signal	YD			
XE		YE	XE	Conversion completion flag	YE			
XF		YF	XF	Error flag	YF	Error clear request		
X10		Not used	Y10	Not used				
X11			Y11	Not used				
X12			Y12	Error code reset flag				
X13			Y13	Not used				
X14			Y14	Not used				
X15	Y15		Not used					
X16	Y16		Not used					
X17	Y17		Not used					
X18	Y18		Not used					
X19	Y19		Not used					
X1A	Interlock signal for the RFRP and RTOP instructions when the A68RD3N is used in remote I/O station	Y1A	Not used					
X1B		Y1B	Not used					
X1C		Y1C	Not used					
X1D		Y1D	Not used					
X1E	Y1E	Not used						
X1F	Y1F	Not used						

4.4.4 Buffer memory address comparison

Sequence program change is required as the assignment of buffer memory differs.

For details of the buffer memories and sequence program, refer to the RTD Input Module/Channel Isolated RTD Input Module User's Manual.

A68RD3N			Q64RD			
Address (decimal)	Name	Read/write	Address (decimal)	Name	Read/write	
0	Conversion enable/disable specification	R/W	0	Conversion enable/disable specification	R/W	
1	Averaging processing selection		1	CH1 Time/count averaging setting		
2	CH1 Averaging time/count		2	CH2 Time/count averaging setting		
3	CH2 Averaging time/count		3	CH3 Time/count averaging setting		
4	CH3 Averaging time/count		4	CH4 Time/count averaging setting	-	
5	CH4 Averaging time/count		5	System area (Not used)		
6	CH5 Averaging time/count		6			
7	CH6 Averaging time/count		7			
8	CH7 Averaging time/count		8			
9	CH8 Averaging time/count	9	Averaging processing selection	R/W		
10	CH1 Detected temperature value (16bit)	R	10	Conversion completion flag	R	
11	CH2 Detected temperature value (16bit)		11	CH1 Measured temperature value (16bit)		
12	CH3 Detected temperature value (16bit)		12	CH2 Measured temperature value (16bit)		
13	CH4 Detected temperature value (16bit)		13	CH3 Measured temperature value (16bit)		
14	CH5 Detected temperature value (16bit)		14	CH4 Measured temperature value (16bit)	-	
15	CH6 Detected temperature value (16bit)		15	System area (Not used)		
16	CH7 Detected temperature value (16bit)		16			
17	CH8 Detected temperature value (16bit)		17			
18	CH1 Detected temperature value (L)		18		Error code	R
19	(32bit) (H)		19			
20	CH2 Detected temperature value (L)		20	Setting range		
21	(32bit) (H)		21	System area (Not used)		
22	CH3 Detected temperature value (L)		22			
23	(32bit) (H)		23			
24	CH4 Detected temperature value (L)		24			
25	(32bit) (H)		25			
26	CH5 Detected temperature value (L)	26				
27	(32bit) (H)	27				
28	CH6 Detected temperature value (L)	28				
29	(32bit) (H)	29				
30	CH7 Detected temperature value (L)	30				
31	(32bit) (H)	31				
32	CH8 Detected temperature value (L)	32				
33	(32bit) (H)	33				
34	Write data error code	R/W	34		Warning output enable/disable setting	R/W
35	Conversion completion flag	R	35			
36	Specification of platinum RTD type	R/W	36			
			37			
			38			
			39			
			40			
			41			
			42			
			43			
			44			
			45			
			46			
			47			

Q64RD			
Address (decimal)	Name	Read/write	
48	Warning output flag	R	
49	Disconnection detection flag		
50	CH1 Scaling value		
51	CH2 Scaling value		
52	CH3 Scaling value		
53	CH4 Scaling value		
54	CH1 Measured temperature value (L)		
55	(32bit) (H)		
56	CH2 Measured temperature value (L)		
57	(32bit) (H)		
58	CH3 Measured temperature value (L)		
59	(32bit) (H)		
60	CH4 Measured temperature value (L)		
61	(32bit) (H)		
62	CH1 Scaling range lower limit value (L)		R/W
63	(H)		
64	CH1 Scaling range upper limit value (L)		
65	(H)		
66	CH2 Scaling range lower limit value (L)		
67	(H)		
68	CH2 Scaling range upper limit value (L)		
69	(H)		
70	CH3 Scaling range lower limit value (L)		
71	(H)		
72	CH3 Scaling range upper limit value (L)		
73	(H)		
74	CH4 Scaling range lower limit value (L)		
75	(H)		
76	CH4 Scaling range upper limit value (L)		
77	(H)		
78	CH1 Scaling width lower limit value		
79	CH1 Scaling width upper limit value		
80	CH2 Scaling width lower limit value		
81	CH2 Scaling width upper limit value		
82	CH3 Scaling width lower limit value		
83	CH3 Scaling width upper limit value		
84	CH4 Scaling width lower limit value		
85	CH4 Scaling width upper limit value		
86	CH1 Warning output lower (L)		
87	lower limit value (H)		
88	CH1 Warning output lower (L)		
89	upper limit value (H)		
90	CH1 Warning output upper (L)		
91	lower limit value (H)		
92	CH1 Warning output upper (L)		
93	upper limit value (H)		
to			
116	CH4 Warning output upper (L)	R/W	
117	upper limit value (H)		
118	CH1 Offset temperature setting value (L)		
119	(H)		
120	CH1 Gain temperature setting value (L)		
121	(H)		
to			

Q64RD		
Address (decimal)	Name	Read/write
132	CH4 Gain temperature setting value (L) (H)	R/W
133		
134 to 157	Not used	-
158	Mode switching setting	R/W
159		
160	3-conductor type CH1 Factory default offset value	
to		
254	4-conductor type CH4 User range (L) settings gain resistance value (H)	R/W
255		

4.5 A68RD3N (Replacement to the Q64RD-G)

4.5.1 Performance comparison

Item		A68RD3N
Measuring method		3-wire type
Output (temperature conversion value)		16-bit signed binary -1800 to 6000 Value up to the first decimal place × 10 32-bit signed binary -180000 to 600000 Value up to the third decimal place × 1000
Applicable RTD		Pt100 (JIS C1604-1997, IEC 751-am2, JIS C1604-1989, DIN 43760-1980) JPt100 (JIS C1604-1981)
Measured temperature range	Pt100	-180 to 600°C (27.10 to 313.71Ω)
	JPt100	-180 to 600°C (25.80 to 317.28Ω)
	Ni100	-
Accuracy		±1% (accuracy at full scale)
Resolution		0.025°C
Conversion speed		40ms/channel
Number of analog input points		8 channels/module
Output current for temperature detection		1mA
Isolation method		Between platinum RTD input and programmable controller power supply: photocoupler isolation Between platinum RTD input and channel: non-isolation
Dielectric withstand voltage		Between platinum RTD input and programmable controller power supply: 500VAC, for 1 minute
Disconnection detection		Detected per channel
Number of occupied I/O points		32 points (I/O assignment: special 32 points)
External connection system		38-point terminal block
Applicable wire size		0.75 to 2mm ²
Applicable solderless terminal		V1.25-3, V1.25-YS3A, V2-S3, V2-YS3A

○: Compatible, △: Partial change required, ×: Incompatible

	Q64RD-G	Compatibility	Precautions for replacement												
	3/4-wire type	○													
	16-bit signed binary -2000 to 8500 Value up to the first decimal place × 10 32-bit signed binary -200000 to 850000 Value up to the third decimal place × 1000	○													
	Pt100 (JIS C 1604-1997, IEC751 1983) JPt100 (JIS C 1604-1981) Ni100 (DIN 43760 1987)	△	As the compliance standards for the applicable RTD differ, change the RTD to the one that can be used with the Q64RD-G.												
	-200 to 850°C	○													
	-180 to 600°C														
	-60 to 180°C														
	*1	○													
	0.025°C	○													
	40ms/channel	○													
	4 channels/module	△	Consider replacement with multiple Q64RD-G.												
	1mA	○													
	<table border="1"> <thead> <tr> <th>Isolated area</th> <th>Isolation method</th> <th>Dielectric withstand voltage</th> <th>Insulation resistance</th> </tr> </thead> <tbody> <tr> <td>Between RTD input and programmable controller power supply</td> <td>Photocoupler isolation</td> <td>1780VrmsAC/3 cycles (altitude 2000m)</td> <td>10MΩ or more using 500VDC insulation resistance tester</td> </tr> <tr> <td>Between RTD input and channel</td> <td>Transformer isolation</td> <td>-</td> <td></td> </tr> </tbody> </table>	Isolated area	Isolation method	Dielectric withstand voltage	Insulation resistance	Between RTD input and programmable controller power supply	Photocoupler isolation	1780VrmsAC/3 cycles (altitude 2000m)	10MΩ or more using 500VDC insulation resistance tester	Between RTD input and channel	Transformer isolation	-		○	
Isolated area	Isolation method	Dielectric withstand voltage	Insulation resistance												
Between RTD input and programmable controller power supply	Photocoupler isolation	1780VrmsAC/3 cycles (altitude 2000m)	10MΩ or more using 500VDC insulation resistance tester												
Between RTD input and channel	Transformer isolation	-													
	Detected per channel	○													
	16 points (I/O assignment: intelligent 16 points)	△	The number of occupied I/O points has changed to 16 points.												
	18-point terminal block	×	Wiring change is required.												
	0.3 to 0.75mm ²	×													
	1.25-3, R1.25-3 (Sleeved solderless terminal cannot be used.)	×													

*1 Indicates accuracy of the Q64RD-G (accuracy at the maximum value in the selection range).

Accuracy		Specifications
Reference accuracy		Within 0.04%
Temperature coefficient	Pt100/JPt100 (-20 to 120°C)	±70ppm/°C (±0.0070%/°C)
	Pt100/JPt100 (0 to 200°C)	±65ppm/°C (±0.0065%/°C)
	Pt100/JPt100 (-200 to 850°C)	±50ppm/°C (±0.0050%/°C)
	Ni100Ω (-60 to 180°C)	±70ppm/°C (±0.0070%/°C)

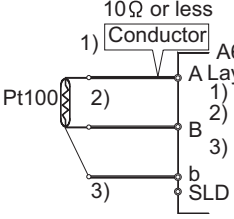
Item	A68RD3N	
Cable between module and RTD	<p>Make sure that the conductor resistance value between the Pt100 and A68RD3N is 10Ω or less per conductor. All channels become the same specifications.</p>  <p>A Lay wiring so that the following conditions are met.</p> <ol style="list-style-type: none"> 1) Conductor resistance value $\leq 10 (\Omega)$ 2) Conductor resistance value $\leq 10 (\Omega)$ 3) Conductor resistance value $\leq 10 (\Omega)$ 	
Internal current consumption (5VDC)	0.94A	
Weight	0.43kg	

○ : Compatible, △ : Partial change required, × : Incompatible

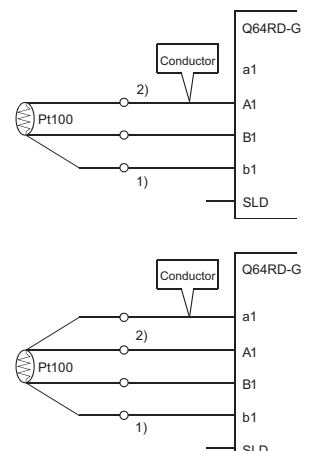
Q64RD-G	Compatibility	Precautions for replacement
<p>The conductor resistance value must meet the condition of $1) + 2) \leq 2k\Omega$ or less. (In the case of 3-conductor type, the difference between 1) and 2) in the conductor resistance value must be 10Ω or less.)</p> 	○	
0.62A	○	
0.20kg	○	

4.5.2 Functional comparison

○ : Available, - : Not available

Item	Description	A68RD3N	Q64RD-G	Precautions for replacement
Conversion enable/disable specification of each channel	Enables/disables a detection of temperature.	○	○	
Sampling/averaging processing selection	Processes the detected temperature by specified method.	○	○	The setting ranges of time and count averages differ. Refer to the RTD Input Module/ Channel Isolated RTD Input Module User's Manual to check the specifications.
Detected temperature value storage	Stores temperature data in the buffer memory.	○	○	
Disconnection detection	Detects a disconnection of the connected RTD or cable.	○	○	
Specification of RTD type	Specifies a RTD type used.	○	○	
Range switching function	Switches the measured temperature range.	-	○	
Warning output function	Outputs a warning when the temperature exceeds the set temperature range.	-	○	
Scaling function	Converts a measured temperature value into a percent value (%) in set width.	-	○	
Error correction function	Corrects an error in temperature conversion value.	○	○	Perform the error correction by the offset/gain setting of the Q64RD-G.
Online module replacement	Replaces a module without stopping the system.	-	○	Replaceable modules during online are the Process CPU and the Redundant CPU.

4.5.3 I/O signal comparison to programmable controller CPU

Sequence program change is required as the I/O signals differ.

For details of the I/O signals and sequence program, refer to the RTD Input Module/Channel Isolated RTD Input Module User's Manual.

A68RD3N				Q64RD-G				
Device No.	Signal name	Device No.	Signal name	Device No.	Signal name	Device No.	Signal name	
X0	Watchdog timer error flag	Y0	Not used	X0	Module READY	Y0	Not used	
X1	READY flag	Y1		X1	CH1 Offset/gain setting status signal	Y1	CH1 Offset setting request	
X2	Write data error flag	Y2		X2	CH2 Offset/gain setting status signal	Y2	CH1 Gain setting request	
X3	CH1: Disconnection detection flag	Y3		X3	CH3 Offset/gain setting status signal	Y3	CH2 Offset setting request	
X4	CH2: Disconnection detection flag	Y4		X4	CH4 Offset/gain setting status signal	Y4	CH2 Gain setting request	
X5	CH3: Disconnection detection flag	Y5		Not used	X5	Not used	Y5	CH3 Offset setting request
X6	CH4: Disconnection detection flag	Y6			Y6		CH3 Gain setting request	
X7	CH5: Disconnection detection flag	Y7			Y7		CH4 Offset setting request	
X8	CH6: Disconnection detection flag	Y8			Y8		CH4 Gain setting request	
X9	CH7: Disconnection detection flag	Y9		X9	Operating condition setting completion signal	Y9	Operating condition setting request	
XA	CH8: Disconnection detection flag	YA	XA	Offset/gain setting mode status flag	YA	User range write request		
XB	Not used	YB	XB	Not used	YB	Not used		
XC		YC	XC	Disconnection detection signal	YC			
XD		YD	XD	Warning output signal	YD			
XE		YE	XE	Conversion completion flag	YE			
XF		YF	XF	Error flag	YF	Error clear request		
X10		Not used	Y10					
X11			Y11					
X12			Y12					
X13			Y13					
X14			Y14					
X15	Y15							
X16	Y16							
X17	Y17							
X18	Y18							
X19	Y19							
X1A	Y1A	Not used						
X1B	Y1B							
X1C	Y1C							
X1D	Interlock signal for the RFRP and RTOP instructions when the A68RD3N is used in remote I/O station	Y1D						
X1E	Y1E							
X1F	Y1F							

4.5.4 Buffer memory address comparison

Sequence program change is required as the assignment of buffer memory differs.
 For details of the buffer memory and sequence program, refer to the RTD Input Module/Channel Isolated RTD Input Module User's Manual.

A68RD3N			Q64RD-G		
Address (decimal)	Name	Read/write	Address (decimal)	Name	Read/write
0	Conversion enable/disable specification	R/W	0	Conversion enable/disable setting	R/W
1	Averaging processing selection		1	CH1 Time/count/moving averaging setting	
2	CH1 Averaging time/count		2	CH2 Time/count/moving averaging setting	
3	CH2 Averaging time/count		3	CH3 Time/count/moving averaging setting	
4	CH3 Averaging time/count		4	CH4 Time/count/moving averaging setting	-
5	CH4 Averaging time/count		5	System area (Not used)	
6	CH5 Averaging time/count		to		
7	CH6 Averaging time/count		8		
8	CH7 Averaging time/count		R	9	Averaging processing selection
9	CH8 Averaging time/count	10		Conversion completion flag	R
10	CH1 Detected temperature value (16bit)	11		CH1 Measured temperature value (16bit)	
11	CH2 Detected temperature value (16bit)	12		CH2 Measured temperature value (16bit)	
12	CH3 Detected temperature value (16bit)	13		CH3 Measured temperature value (16bit)	
13	CH4 Detected temperature value (16bit)	14		CH4 Measured temperature value (16bit)	-
14	CH5 Detected temperature value (16bit)	15		System area (Not used)	
15	CH6 Detected temperature value (16bit)	to			
16	CH7 Detected temperature value (16bit)	18			
17	CH8 Detected temperature value (16bit)	19		Error code	R
18	CH1 Detected temperature value(L) (32bit)(H)	20		Setting range 1	
19	CH2 Detected temperature value (L) (32bit) (H)	21		Setting range 2	
20	CH3 Detected temperature value (L) (32bit) (H)	-		22	System area (Not used)
21	CH4 Detected temperature value (L) (32bit) (H)				
22	CH5 Detected temperature value (L) (32bit) (H)				
23	CH6 Detected temperature value (L) (32bit) (H)				
24	CH7 Detected temperature value (L) (32bit) (H)				
25	CH8 Detected temperature value (L) (32bit) (H)				
26	Write data error code		R/W		
27	Conversion completion flag		R		
28	Specification of platinum RTD type		R/W		
29					
30					
31					
32					
33					
34					
35					
36					
37					
38					
39					
40					
41					
42					
43					
44					
45					
46					
47	Warning output enable/disable setting	R/W			

Q64RD-G		
Address (decimal)	Name	Read/write
48	Warning output flag	R
49	Disconnection detection flag	
50 to 53	CH1 to CH4 Scaling value	
54	CH1 Measured temperature value (L)	
55	(32bit) (H)	
to		
60	CH4 Measured temperature value (L)	R
61	(32bit) (H)	
62	CH1 Scaling range lower limit value (L)	R/W
63	(H)	
64	CH1 Scaling range upper limit (L)	
65	value (H)	
to		
76	CH4 Scaling range upper limit (L)	R/W
77	value (H)	
78	CH1 Scaling width lower limit value	
79	CH1 Scaling width upper limit value	
to		
85	CH4 Scaling width upper limit value	R/W
86	CH1 Warning output lower (L)	
87	lower limit value (H)	
88	CH1 Warning output lower (L)	
89	upper limit value (H)	
90	CH1 Warning output upper (L)	
91	lower limit value (H)	
92	CH1 Warning output upper (L)	
93	upper limit value (H)	
to		
116	CH4 Warning output upper (L)	R/W
117	upper limit value (H)	
118	CH1 Offset temperature setting (L)	
119	value (H)	
120	CH1 Gain temperature setting (L)	
121	value (H)	
to		
132	CH4 Gain temperature setting (L)	R/W
133	value (H)	
134	Extended averaging processing selection	
135 to 147	System area (Not used)	-
148	Conversion setting for disconnection detection	R/W
149	System area (Not used)	-

Q64RD-G			
Address (decimal)	Name	Read/write	
150	CH1 Conversion setting value for (L)	R/W	
151	disconnection detection (H)		
to			
156	CH4 Conversion setting value for (L)	R/W	
157	disconnection detection (H)		
158	Mode switching setting		
159			
160	3-conductor type CH1 Factory (L)		
161	default offset value (H)		
162	3-conductor type CH1 Factory (L)		
163	default gain value (H)		
164	3-conductor type CH1 User range (L)		
165	settings offset value (H)		
166	3-conductor type CH1 User range (L)		
167	settings gain value (H)		
168	3-conductor type CH1 User range (L)		
169	settings offset resistance value (H)		
170	3-conductor type CH1 User range (L)		
171	settings gain resistance value (H)		
172	4-conductor type CH1 Factory (L)		
173	default offset value (H)		
174	4-conductor type CH1 Factory (L)		
175	default gain value (H)		
176	4-conductor type CH1 User range (L)		
177	settings offset value (H)		
178	4-conductor type CH1 User range (L)		
179	settings gain value (H)		
180	4-conductor type CH1 User range (L)		
181	settings offset resistance value (H)		
182	4-conductor type CH1 User range (L)		
183	settings gain resistance value (H)		
to			
254	4-conductor type CH4 User range (L)	R/W	
255	settings gain resistance value (H)		

4.6 A68RD3N (Replacement to the Q68RD3-G)

4.6.1 Performance comparison

Item		A68RD3N
Measuring method		3-wire type
Output (temperature conversion value)		16-bit signed binary -1800 to 6000 Value up to the first decimal place × 10 32-bit signed binary -180000 to 600000 Value up to the third decimal place × 1000
Applicable RTD		Pt100 (JIS C1604-1997, IEC 751-am2, JIS C1604-1989, DIN 43760-1980) JPt100 (JIS C1604-1981)
Measured temperature range	Pt100	-180 to 600°C (27.10 to 313.71Ω)
	JPt100	-180 to 600°C (25.80 to 317.28Ω)
	Ni100	-
Accuracy		±1% (accuracy at full scale)
Resolution		0.025°C
Conversion speed		40ms/channel
Number of analog input points		8 channels/module
Output current for temperature detection		1mA
Isolation method		Between platinum RTD input and programmable controller power supply: photocoupler isolation Between platinum RTD input and channel: non-isolation
Dielectric withstand voltage		Between platinum RTD input and programmable controller power supply: 500VAC, for 1 minute
Disconnection detection		Detected per channel
Number of occupied I/O points		32 points (I/O assignment: special 32 points)
External connection system		38-point terminal block
External device connector (sold separately)		-
Applicable wire size		0.75 to 2mm ²
Applicable solderless terminal		V1.25-3, V1.25-YS3A, V2-S3, V2-YS3A

○: Compatible, △: Partial change required, ×: Incompatible

	Q68RD3-G	Compatibility	Precautions for replacement											
	3-wire type	○												
	16-bit signed binary -2000 to 8500 Value up to the first decimal place × 10	△	32-bit output is not available.											
	Pt100 (JIS C 1604-1997, IEC751 1983) JPt100 (JIS C 1604-1981) Ni100 (DIN 43760 1987)	△	As the compliance standards for the applicable RTD differ, change the RTD to the one that can be used with the Q68RD3-G.											
	-200 to 850°C	○												
	-180 to 600°C													
	-60 to 180°C													
	*1	○												
	0.1°C	△	The resolution reduces.											
	320ms/8 channels	△	The conversion speed is fixed at 320ms, regardless of the number of enable channels.											
	8 channels/module	○												
	1mA	○												
	<table border="1"> <thead> <tr> <th>Isolated area</th> <th>Isolation method</th> <th>Dielectric withstand voltage</th> <th>Insulation resistance</th> </tr> </thead> <tbody> <tr> <td>Between RTD input and programmable controller power supply</td> <td>Transformer isolation</td> <td>500VACrms /minute</td> <td rowspan="2">10MΩ or more using 500VDC insulation resistance tester</td> </tr> <tr> <td>Between RTD input and channel</td> <td>Transformer isolation</td> <td>1000VACrms /minute</td> </tr> </tbody> </table>	Isolated area	Isolation method	Dielectric withstand voltage	Insulation resistance	Between RTD input and programmable controller power supply	Transformer isolation	500VACrms /minute	10MΩ or more using 500VDC insulation resistance tester	Between RTD input and channel	Transformer isolation	1000VACrms /minute	○	
Isolated area	Isolation method	Dielectric withstand voltage	Insulation resistance											
Between RTD input and programmable controller power supply	Transformer isolation	500VACrms /minute	10MΩ or more using 500VDC insulation resistance tester											
Between RTD input and channel	Transformer isolation	1000VACrms /minute												
	Detected per channel	○												
	16 points (I/O assignment: intelligent 16 points)	△	The number of occupied I/O points has changed to 16 points.											
	40-pin connector	×	Wiring change is required.											
	A6CON4	×	Prepare the A6CON4 separately.											
	0.3 mm ²	×												
	-	×												

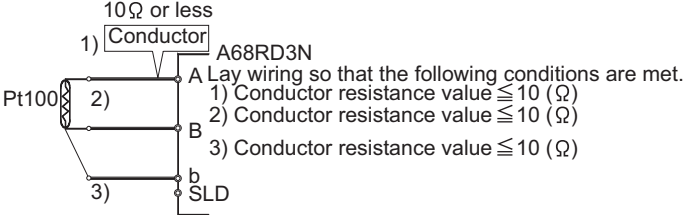
Item	A68RD3N	
<p>Cables between module and RTD</p>	<p>Make sure that the conductor resistance value between the Pt100 and A68RD3N is 10Ω or less per conductor. All channels become the same specifications.</p>  <p>10Ω or less Conductor Pt100 1) 2) 3) A68RD3N A B b SLD</p> <p>Lay wiring so that the following conditions are met. 1) Conductor resistance value ≤ 10 (Ω) 2) Conductor resistance value ≤ 10 (Ω) 3) Conductor resistance value ≤ 10 (Ω)</p>	
<p>Internal current consumption (5VDC)</p>	<p>0.94A</p>	
<p>Weight</p>	<p>0.43kg</p>	

○ : Compatible, △ : Partial change required, × : Incompatible

	Q68RD3-G	Compatibility	Precautions for replacement
	*2	△	Install a relay terminal block outside.
	0.54A	○	
	0.20kg	○	

*1 Accuracy of the Q68RD3-G for each RTD type is as follows.

Conversion accuracy		Specifications
Pt100	-200 to 850°C*1	±0.8°C (Ambient temperature: 25±5°C), ±2.4°C (Ambient temperature: 0 to 55°C)
	-20 to 120°C*1	±0.3°C (Ambient temperature: 25±5°C), ±1.1°C (Ambient temperature: 0 to 55°C)
	0 to 200°C*1	±0.4°C (Ambient temperature: 25±5°C), ±1.2°C (Ambient temperature: 0 to 55°C)
JPt100	-180 to 600°C*1	±0.8°C (Ambient temperature: 25±5°C), ±2.4°C (Ambient temperature: 0 to 55°C)
	-20 to 120°C*1	±0.3°C (Ambient temperature: 25±5°C), ±1.1°C (Ambient temperature: 0 to 55°C)
	0 to 200°C*1	±0.4°C (Ambient temperature: 25±5°C), ±1.2°C (Ambient temperature: 0 to 55°C)
Ni100	-60 to 180°C*1	±0.4°C (Ambient temperature: 25±5°C), ±1.2°C (Ambient temperature: 0 to 55°C)

*2 Connect cables between the Q68RD3-G and RTD using a relay terminal block as shown below.

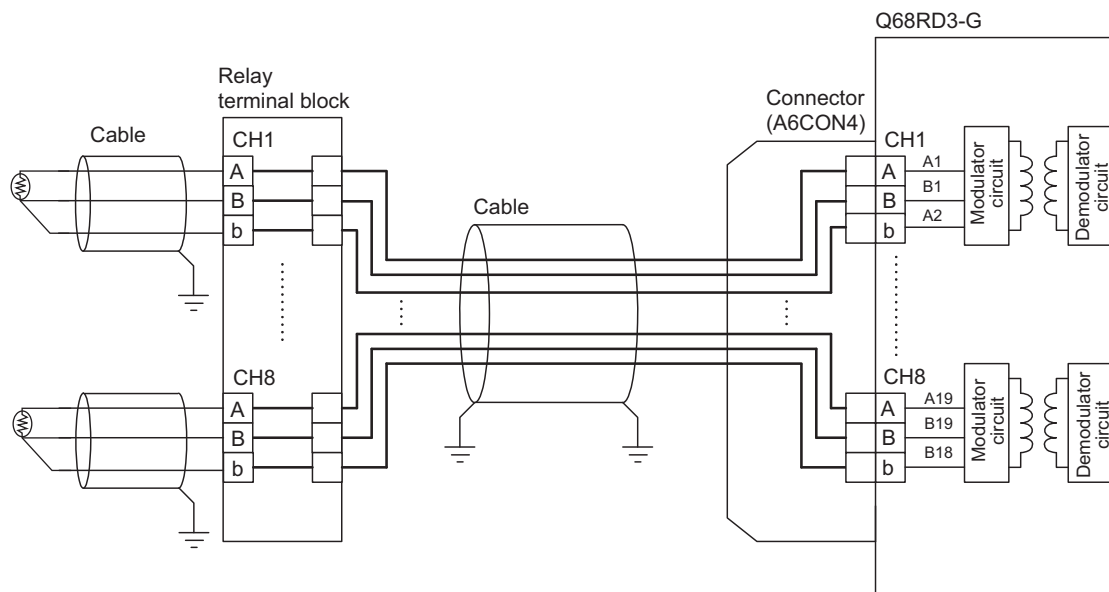

4.6.2 Functional comparison

○ : Available, - : Not available

Item	Description	A68RD3N	Q68RD3-G	Precautions for replacement
Conversion enable/disable specification of each channel	Enables/disables a detection of temperature.	○	○	
Sampling/averaging processing selection	Processes the detected temperature by specified method.	○	○	The setting ranges of time and count averages differ. Refer to the RTD Input Module/ Channel Isolated RTD Input Module User's Manual to check the specifications.
Detected temperature value storage	Stores temperature data in the buffer memory.	○	○	
Disconnection detection	Detects a disconnection of the connected RTD or cable.	○	○	
Specification of RTD type	Specifies a RTD type used.	○	○	
Range switching function	Switches the measured temperature range.	-	○	
Warning output function	Outputs a warning when the temperature exceeds the set temperature range.	-	○	
Scaling function	Converts a measured temperature value into a percent value (%) in set width.	-	○	
Error correction function	Corrects an error in temperature conversion value.	○	○	Perform the error correction by the offset/gain setting of the Q68RD3-G.
Online module replacement	Replaces a module without stopping the system.	-	○	Replaceable modules during online are the Process CPU and the Redundant CPU.

4.6.3 I/O signal comparison to programmable controller CPU

Sequence program change is required as the I/O signals differ.

For details of the I/O signals and sequence program, refer to the RTD Input Module/Channel Isolated RTD Input Module User's Manual.

A68RD3N				Q68RD3-G				
Device No.	Signal name	Device No.	Signal name	Device No.	Signal name	Device No.	Signal name	
X0	Watchdog timer error flag	Y0	Not used	X0	Module READY	Y0	Not used	
X1	READY flag	Y1		X1		Y1		
X2	Write data error flag	Y2		X2		Y2		
X3	CH1: Disconnection detection flag	Y3		X3		Y3		
X4	CH2: Disconnection detection flag	Y4		X4		Y4		
X5	CH3: Disconnection detection flag	Y5		X5	Not used	Y5		
X6	CH4: Disconnection detection flag	Y6		X6		Y6		
X7	CH5: Disconnection detection flag	Y7		X7		Y7		
X8	CH6: Disconnection detection flag	Y8		X8		Y8		
X9	CH7: Disconnection detection flag	Y9		X9	Operating condition setting completion flag	Y9		Operating condition setting request
XA	CH8: Disconnection detection flag	YA		XA	Offset/gain setting mode status flag	YA		User range write request
XB	Not used	YB		XB	Channel change completion flag	YB		Channel change request
XC		YC		XC	Disconnection detection signal	YC		Not used
XD		YD		XD	Warning output signal	YD		
XE		YE	XE	Conversion completion flag	YE			
XF		YF	XF	Error flag	YF	Error clear request		
X10		Not used	Y10	Not used				
X11			Y11					
X12			Y12	Error code reset flag				
X13			Y13					
X14			Y14					
X15	Y15							
X16	Y16							
X17	Y17							
X18	Y18							
X19	Y19							
X1A	Not used	Y1A						
X1B		Y1B						
X1C		Y1C						
X1D	Interlock signal for the RFRP and RTOP instructions when the A68RD3N is used in remote I/O station	Y1D						
X1E		Y1E						
X1F		Y1F						

4.6.4 Buffer memory address comparison

Sequence program change is required as the assignment of buffer memory differs.

For details of the buffer memory and sequence program, refer to the RTD Input Module/Channel Isolated RTD Input Module User's Manual.

A68RD3N			Q68RD3-G			
Address (decimal)	Name	Read/write	Address (decimal)	Name	Read/write	
0	Conversion enable/disable specification	R/W	0	Conversion enable/disable setting	R/W	
1	Averaging processing selection		1	CH1 Time/count/moving average/time constant setting		
2	CH1 Averaging time/count		2	CH2 Time/count/moving average/time constant setting		
3	CH2 Averaging time/count		3	CH3 Time/count/moving average/time constant setting		
4	CH3 Averaging time/count		4	CH4 Time/count/moving average/time constant setting		
5	CH4 Averaging time/count		5	CH5 Time/count/moving average/time constant setting		
6	CH5 Averaging time/count		6	CH6 Time/count/moving average/time constant setting		
7	CH6 Averaging time/count		7	CH7 Time/count/moving average/time constant setting		
8	CH7 Averaging time/count		8	CH8 Time/count/moving average/time constant setting		
9	CH8 Averaging time/count	R	9	System area (Not used)	-	
10	CH1 Detected temperature value (16bit)		10	Conversion completion flag	R	
11	CH2 Detected temperature value (16bit)		11	CH1 Measured temperature value		
12	CH3 Detected temperature value (16bit)		12	CH2 Measured temperature value		
13	CH4 Detected temperature value (16bit)		13	CH3 Measured temperature value		
14	CH5 Detected temperature value (16bit)		14	CH4 Measured temperature value		
15	CH6 Detected temperature value (16bit)		15	CH5 Measured temperature value		
16	CH7 Detected temperature value (16bit)		16	CH6 Measured temperature value		
17	CH8 Detected temperature value (16bit)		17	CH7 Measured temperature value		
18	CH1 Detected temperature value (L)		18	CH8 Measured temperature value		
19	(32bit) (H)		19	Error code		
20	CH2 Detected temperature value (L)		20	Setting range 1 (Input type CH1-4)		
21	(32bit) (H)		21	Setting range 2 (Input type CH5-8)		
22	CH3 Detected temperature value (L)		22	Setting range 3 (Offset/gain setting)		
23	(32bit) (H)		23	System area (Not used)		-
24	CH4 Detected temperature value (L)		24	Averaging processing selection (CH1-CH4)		R/W
25	(32bit) (H)		25	Averaging processing selection (CH5-CH8)		
26	CH5 Detected temperature value (L)		26	Offset/gain setting mode (Offset specification)		
27	(32bit) (H)	27	Offset/gain setting mode (Gain specification)			
28	CH6 Detected temperature value (L)	28	CH1 Offset temperature setting value			
29	(32bit) (H)	29	CH1 Gain temperature setting value			
30	CH7 Detected temperature value (L)	R	30	CH2 Offset temperature setting value		
31	(32bit) (H)		31	CH2 Gain temperature setting value		
32	CH8 Detected temperature value (L)		32	CH3 Offset temperature setting value		
33	(32bit) (H)		33	CH3 Gain temperature setting value		
34	Write data error code	R/W	34	CH4 Offset temperature setting value		
35	Conversion completion flag	R	35	CH4 Gain temperature setting value		
36	Specification of platinum RTD type	R/W	36	CH5 Offset temperature setting value		
			37	CH5 Gain temperature setting value		
			38	CH6 Offset temperature setting value		
			39	CH6 Gain temperature setting value		

Q68RD3-G		
Address (decimal)	Name	Read/write
40	CH7 Offset temperature setting value	R/W
41	CH7 Gain temperature setting value	
42	CH8 Offset temperature setting value	
43	CH8 Gain temperature setting value	
44 to 45	System area (Not used)	-
46	Warning output enable/disable setting	R/W
47	Warning output flag (Process alarm)	R
48	Warning output flag (Rate alarm)	
49	Disconnection detection flag	
50 to 57	CH1 to CH8 Scaling value	
58	Scaling valid/invalid setting	R/W
59 to 61	System area (Not used)	-
62	CH1 Scaling range lower limit value	R/W
63	CH1 Scaling range upper limit value	
to		
77	CH8 Scaling range upper limit value	R/W
78	CH1 Scaling width lower limit value	
79	CH1 Scaling width upper limit value	
to		
93	CH8 Scaling width upper limit value	R/W
94	CH1 Process alarm lower/lower limit value	
95	CH1 Process alarm lower/upper limit value	
96	CH1 Process alarm upper/lower limit value	
97	CH1 Process alarm upper/upper limit value	
to		
125	CH8 Process alarm upper/upper limit value	R/W
126 to 133	CH1 to CH8 Rate alarm warning detection period	
134	CH1 Rate alarm upper limit value	
135	CH1 Rate alarm lower limit value	
to		
149	CH8 Rate alarm lower limit value	R/W
150 to 157	System area (Not used)	-
158 to 159	Mode switching setting	R/W
160 to 163	System area (Not used)	-
164	Conversion setting for disconnection detection (CH1-CH4)	R/W
165	Conversion setting for disconnection detection (CH5-CH8)	
166 to 173	CH1 to CH8 Conversion setting value for disconnection detection	
174 to 189	System area	-
190	CH1 Factory default offset value	R/W
191	CH1 Factory default gain value	
192	CH1 User range settings offset value	
193	CH1 User range settings gain value	
194	CH1 User range settings offset (L)	
195	resistance value (H)	
196	CH1 User range settings gain (L)	
197	resistance value (H)	
to		
253	CH8 User range settings gain resistance value (H)	R/W

4.7 A68RD4N (Replacement to the Q64RD)

4.7.1 Performance comparison

Item		A68RD4N
Measuring method		4-wire type
Output (temperature conversion value)		16-bit signed binary -1800 to 6000 Value up to the first decimal place × 10 32-bit signed binary -180000 to 600000 Value up to the third decimal place × 1000
Applicable platinum RTD		Pt100 (JIS C1604-1997, IEC 751-am2, JIS C1604-1989, DIN 43760-1980) JPt100 (JIS C1604-1981)
Measured temperature range	Pt100	-180 to 600°C (27.10 to 313.71Ω)
	JPt100	-180 to 600°C (25.80 to 317.28Ω)
Accuracy		±1% (accuracy at full scale)
Resolution		0.025°C
Conversion speed		40ms/channel
Number of analog input points		8 channels/module
Output current for temperature detection		1mA
Isolation method		Between platinum RTD input and programmable controller power supply: photocoupler isolation Between platinum RTD input and channel: non-isolation
Dielectric withstand voltage		Between platinum RTD input and programmable controller power supply: 500VAC, for 1 minute
Disconnection detection		Batch-detected at all channels
Number of occupied I/O points		32 points (I/O assignment: special 32 points)
External connection system		38-point terminal block
Applicable wire size		0.75 to 2mm ²
Applicable solderless terminal		V1.25-3, V1.25-YS3A, V2-S3, V2-YS3A

○ : Compatible, △ : Partial change required, × : Incompatible

	Q64RD	Compatibility	Precautions for replacement											
	3/4-wire type	○												
	16-bit signed binary -2000 to 8500 Value up to the first decimal place × 10 32-bit signed binary data -200000 to 850000 Value up to the third decimal place × 1000	○												
	Pt100 (JIS C 1604-1997, IEC751 1983) JPt100 (JIS C 1604-1981)	△	As the compliance standards for the applicable platinum RTD differ, change the platinum RTD to the one that can be used with the Q64RD.											
	-200 to 850°C	○												
	-180 to 600°C													
	Ambient temperature 0 to 55°C: ±0.25% (accuracy relative to maximum value) Ambient temperature 25±5°C: ±0.08% (accuracy relative to maximum value)	○												
	0.025°C	○												
	40ms/channel	○												
	4 channels/module	△	Consider replacement with multiple Q64RD.											
	1mA	○												
	<table border="1"> <thead> <tr> <th>Isolated area</th> <th>Isolation method</th> <th>Dielectric withstand voltage</th> <th>Insulation resistance</th> </tr> </thead> <tbody> <tr> <td>Between platinum RTD input and programmable controller power supply</td> <td>Photocoupler isolation</td> <td>1780VrmsAC/3 cycles (altitude 2000m)</td> <td rowspan="2">10MΩ or more using 500VDC insulation resistance tester</td> </tr> <tr> <td>Between platinum RTD input and channel</td> <td>Non-isolation</td> <td>-</td> </tr> </tbody> </table>	Isolated area	Isolation method	Dielectric withstand voltage	Insulation resistance	Between platinum RTD input and programmable controller power supply	Photocoupler isolation	1780VrmsAC/3 cycles (altitude 2000m)	10MΩ or more using 500VDC insulation resistance tester	Between platinum RTD input and channel	Non-isolation	-	○	
Isolated area	Isolation method	Dielectric withstand voltage	Insulation resistance											
Between platinum RTD input and programmable controller power supply	Photocoupler isolation	1780VrmsAC/3 cycles (altitude 2000m)	10MΩ or more using 500VDC insulation resistance tester											
Between platinum RTD input and channel	Non-isolation	-												
	Detected per channel	○												
	16 points (I/O assignment: intelligent 16 points)	△	The number of occupied I/O points has changed to 16 points.											
	18-point terminal block	×	Wiring change is required.											
	0.3 to 0.75mm ²	×												
	1.25-3, R1.25-3 (Sleeved solderless terminal cannot be used.)	×												

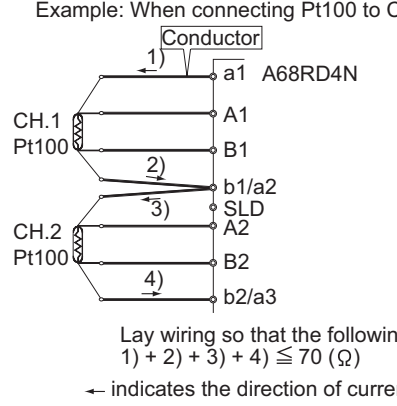
Item	A68RD4N	
Cable between module and platinum RTD	<p>Set the total resistance value of a conductor where the current runs to 70Ω or less.</p> <p>Example: When connecting Pt100 to CH1 and CH2</p>  <p>Lay wiring so that the following condition is met. $1) + 2) + 3) + 4) \leq 70 (\Omega)$ ← indicates the direction of current.</p>	
Internal current consumption (5VDC)	0.41A	
Weight	0.43kg	

○ : Compatible, △ : Partial change required, × : Incompatible

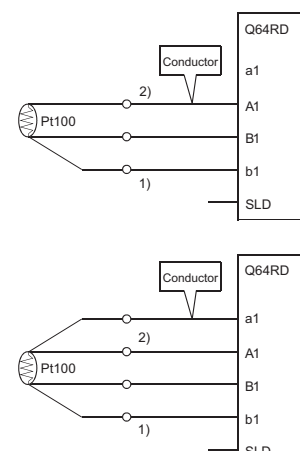
	Q64RD	Compatibility	Precautions for replacement
	<p>The conductor resistance value must meet the condition of $1) + 2) \leq 2k\Omega$ or less. (In the case of 3-conductor type, the difference between 1) and 2) in the conductor resistance value must be 10Ω or less.)</p> 	○	
	0.60A	△	The recalculation of internal current consumption (5VDC) is required.
	0.17kg	○	

4.7.2 Functional comparison

○ : Available, - : Not available

Item	Description	A68RD4N	Q64RD	Precautions for replacement
Conversion enable/disable specification of each channel	Enables/disables a detection of temperature.	○	○	
Sampling/averaging processing selection	Processes the detected temperature by specified method.	○	○	The setting ranges of time and count averages differ. Refer to the RTD Input Module/ Channel Isolated RTD Input Module User's Manual to check the specifications.
Detected temperature value storage	Stores temperature data in the buffer memory.	○	○	
Disconnection detection	This function detects connected platinum RTD or cable breakage.	○	○	For the Q64RD, a disconnection is detected per channel.
Specification of platinum RTD type	Specifies a platinum RTD type used.	○	○	
Range switching function	Switches the measured temperature range.	-	○	
Warning output function	Outputs a warning when the temperature exceeds the set temperature range.	-	○	
Scaling function	Converts a measured temperature value into a percent value (%) in set width.	-	○	
Error correction function	Corrects an error in temperature conversion value.	○	○	Perform the error correction by the offset/gain setting of the Q64RD.
Online module replacement	Replaces a module without stopping the system.	-	○	Replaceable modules during online are the Process CPU and the Redundant CPU.

4.7.3 I/O signal comparison to programmable controller CPU

Sequence program change is required as the I/O signals differ.

For details of the I/O signals and sequence program, refer to the RTD Input Module/Channel Isolated RTD Input Module User's Manual.

A68RD4N				Q64RD				
Device No.	Signal name	Device No.	Signal name	Device No.	Signal name	Device No.	Signal name	
X0	Watchdog timer error flag	Y0	Not used	X0	Module READY	Y0	Not used	
X1	READY flag	Y1		X1	CH1 Offset/gain setting status signal	Y1	CH1 Offset setting request	
X2	Write data error flag	Y2		X2	CH2 Offset/gain setting status signal	Y2	CH1 Gain setting request	
X3	Σ disconnection detection flag (CH1 to CH8)	Y3		X3	CH3 Offset/gain setting status signal	Y3	CH2 Offset setting request	
X4	Not used	Y4		X4	CH4 Offset/gain setting status signal	Y4	CH2 Gain setting request	
X5		Y5		X5	Not used	Y5	CH3 Offset setting request	
X6		Y6		X6		Y6	CH3 Gain setting request	
X7		Y7		X7		Y7	CH4 Offset setting request	
X8		Y8		X8		Y8	CH4 Gain setting request	
X9		Y9		X9	Operating condition setting completion signal	Y9	Operating condition setting request	
XA		YA		XA	Offset/gain setting mode status flag	YA	User range write request	
XB		YB		XB	Not used	YB	Not used	
XC		YC		XC	Disconnection detection signal	YC		
XD		YD		XD	Interlock signal for the RFRP and RTOP instructions when the A68RD4N is used in remote I/O station	YD		Warning output signal
XE	YE	XE		Interlock signal for the RFRP and RTOP instructions when the A68RD4N is used in remote I/O station	YE	Conversion completion flag		
XF	YF	XF			Error flag	YF	Error clear request	
X10	Not used	Y10	Not used					
X11		Y11						
X12		Y12						Error code reset flag
X13		Y13						
X14		Y14						
X15		Y15						
X16		Y16						
X17		Y17						
X18		Y18						
X19		Y19						
X1A	Y1A	Not used						
X1B	Y1B							
X1C	Y1C							
X1D	Y1D	Interlock signal for the RFRP and RTOP instructions when the A68RD4N is used in remote I/O station						
X1E	Y1E							
X1F	Y1F							

4.7.4 Buffer memory address comparison

Sequence program change is required as the assignment of buffer memory differs.

For details of the buffer memory and sequence program, refer to the RTD Input Module/Channel Isolated RTD Input Module User's Manual.

A68RD4N			Q64RD				
Address (decimal)	Name	Read/write	Address (decimal)	Name	Read/write		
0	Conversion enable/disable specification	R/W	0	Conversion enable/disable specification	R/W		
1	Averaging processing selection		1	CH1 Time/count averaging setting			
2	CH1 Averaging time/count		2	CH2 Time/count averaging setting			
3	CH2 Averaging time/count		3	CH3 Time/count averaging setting			
4	CH3 Averaging time/count		4	CH4 Time/count averaging setting	-		
5	CH4 Averaging time/count		5	System area (Not used)			
6	CH5 Averaging time/count		6				
7	CH6 Averaging time/count		7				
8	CH7 Averaging time/count		8				
9	CH8 Averaging time/count	9	Averaging processing selection	R/W			
10	CH1 Detected temperature value (16bit)	R	10	Conversion completion flag	R		
11	CH2 Detected temperature value (16bit)		11	CH1 Measured temperature value (16bit)			
12	CH3 Detected temperature value (16bit)		12	CH2 Measured temperature value (16bit)			
13	CH4 Detected temperature value (16bit)		13	CH3 Measured temperature value (16bit)			
14	CH5 Detected temperature value (16bit)		14	CH4 Measured temperature value (16bit)	-		
15	CH6 Detected temperature value (16bit)		15	System area (Not used)			
16	CH7 Detected temperature value (16bit)		16				
17	CH8 Detected temperature value (16bit)		17				
18	CH1 Detected temperature value (L)		18		Error code	R	
19	(32bit) (H)		19				
20	CH2 Detected temperature value (L)		20	Setting range	-		
21	(32bit) (H)		21	System area (Not used)			
22	CH3 Detected temperature value (L)		22				
23	(32bit) (H)		23				
24	CH4 Detected temperature value (L)		24				
25	(32bit) (H)		25				
26	CH5 Detected temperature value (L)	26					
27	(32bit) (H)	27					
28	CH6 Detected temperature value (L)	28					
29	(32bit) (H)	29					
30	CH7 Detected temperature value (L)	30					
31	(32bit) (H)	31					
32	CH8 Detected temperature value (L)	32					
33	(32bit) (H)	33					
34	Write data error code	R/W	34			Warning output enable/disable setting	R/W
35	Conversion completion flag	R	35				
36	Specification of platinum RTD type	R/W	36				
			37				
			38				
			39				
			40				
			41				
			42				
			43				
			44				
			45				
			46				
			47				

Q64RD			
Address (decimal)	Name	Read/write	
48	Warning output flag	R	
49	Disconnection detection flag		
50	CH1 Scaling value		
51	CH2 Scaling value		
52	CH3 Scaling value		
53	CH4 Scaling value		
54	CH1 Measured temperature value (L)		
55	(32bit) (H)		
56	CH2 Measured temperature value (L)		
57	(32bit) (H)		
58	CH3 Measured temperature value (L)		
59	(32bit) (H)		
60	CH4 Measured temperature value (L)		
61	(32bit) (H)		
62	CH1 Scaling range lower limit value (L)		R/W
63	(H)		
64	CH1 Scaling range upper limit value (L)		
65	(H)		
66	CH2 Scaling range lower limit value (L)		
67	(H)		
68	CH2 Scaling range upper limit value (L)		
69	(H)		
70	CH3 Scaling range lower limit value (L)		
71	(H)		
72	CH3 Scaling range upper limit value (L)		
73	(H)		
74	CH4 Scaling range lower limit value (L)		
75	(H)		
76	CH4 Scaling range upper limit value (L)		
77	(H)		
78	CH1 Scaling width lower limit value		
79	CH1 Scaling width upper limit value		
80	CH2 Scaling width lower limit value		
81	CH2 Scaling width upper limit value		
82	CH3 Scaling width lower limit value		
83	CH3 Scaling width upper limit value		
84	CH4 Scaling width lower limit value		
85	CH4 Scaling width upper limit value		
86	CH1 Warning output lower/lower (L)		
87	limit value (H)		
88	CH1 Warning output lower/upper (L)		
89	limit value (H)		
90	CH1 Warning output upper/lower (L)		
91	limit value (H)		
92	CH1 Warning output upper/upper (L)		
93	limit value (H)		
to			
116	CH4 Warning output upper/upper (L)	R/W	
117	limit value (H)		
118	CH1 Offset temperature setting (L)		
119	value (H)		
120	CH1 Gain temperature setting (L)		
121	value (H)		
to			
132	CH4 Gain temperature setting (L)	R/W	
133	value (H)		

Q64RD		
Address (decimal)	Name	Read/write
134 to 157	Not used	-
158	Mode switching setting	R/W
159		
160	3-conductor type CH1 Factory default offset value to	R/W
254	4-conductor type CH4 User range (L)	
255	settings gain resistance value (H)	R/W

4.8 A68RD4N (Replacement to the Q64RD-G)

4.8.1 Performance comparison

Item		A68RD4N
Measuring method		4-wire type
Output (temperature conversion value)		16-bit signed binary -1800 to 6000 Value up to the first decimal place × 10 32-bit signed binary -180000 to 600000 Value up to the third decimal place × 1000
Applicable RTD		Pt100 (JIS C1604-1997, IEC 751-am2, JIS C1604-1989, DIN 43760-1980) JPt100 (JIS C1604-1981)
Measured temperature range	Pt100	-180 to 600°C (27.10 to 313.71Ω)
	JPt100	-180 to 600°C (25.80 to 317.28Ω)
	Ni100	-
Accuracy		±1% (accuracy at full scale)
Resolution		0.025°C
Conversion speed		40ms/channel
Number of analog input points		8 channels/module
Output current for temperature detection		1mA
Isolation method		Between platinum RTD input and programmable controller power supply: photocoupler isolation Between platinum RTD input and channel: non-isolation
Dielectric withstand voltage		Between platinum RTD input and programmable controller power supply: 500VAC, for 1 minute
Disconnection detection		Batch-detected at all channels
Number of occupied I/O points		32 points (I/O assignment: special 32 points)
External connection system		38-point terminal block
Applicable wire size		0.75 to 2mm ²
Applicable solderless terminal		V1.25-3, V1.25-YS3A, V2-S3, V2-YS3A

○: Compatible, △: Partial change required, ×: Incompatible

	Q64RD-G	Compatibility	Precautions for replacement											
	3/4-wire type	○												
	16-bit signed binary -2000 to 8500 Value up to the first decimal place × 10 32-bit signed binary data -200000 to 850000 Value up to the third decimal place × 1000	○												
	Pt100 (JIS C 1604-1997, IEC751 1983) JPt100 (JIS C 1604-1981) Ni100 (DIN 43760 1987)	△	As the compliance standards for the applicable RTD differ, change the RTD to the one that can be used with the Q64RD-G.											
	-200 to 850°C	○												
	-180 to 600°C													
	-60 to 180°C													
	*1	○												
	0.025°C	○												
	40ms/channel	○												
	4 channels/module	△	Consider replacement with multiple Q64RD-G.											
	1mA	○												
	<table border="1"> <thead> <tr> <th>Isolated area</th> <th>Isolation method</th> <th>Dielectric withstand voltage</th> <th>Insulation resistance</th> </tr> </thead> <tbody> <tr> <td>Between RTD input and programmable controller power supply</td> <td>Photocoupler isolation</td> <td>1780VrmsAC/3 cycles (altitude 2000m)</td> <td rowspan="2">10MΩ or more using 500VDC insulation resistance tester</td> </tr> <tr> <td>Between RTD input and channel</td> <td>Transformer isolation</td> <td>-</td> </tr> </tbody> </table>	Isolated area	Isolation method	Dielectric withstand voltage	Insulation resistance	Between RTD input and programmable controller power supply	Photocoupler isolation	1780VrmsAC/3 cycles (altitude 2000m)	10MΩ or more using 500VDC insulation resistance tester	Between RTD input and channel	Transformer isolation	-	○	
Isolated area	Isolation method	Dielectric withstand voltage	Insulation resistance											
Between RTD input and programmable controller power supply	Photocoupler isolation	1780VrmsAC/3 cycles (altitude 2000m)	10MΩ or more using 500VDC insulation resistance tester											
Between RTD input and channel	Transformer isolation	-												
	Detected per channel	○												
	16 points (I/O assignment: intelligent 16 points)	△	The number of occupied I/O points has changed to 16 points.											
	18-point terminal block	×	Wiring change is required.											
	0.3 to 0.75mm ²	×												
	1.25-3 R1.25-3 (Sleeved solderless terminal cannot be used.)	×												

*1 Indicates accuracy of the Q64RD-G (accuracy at the maximum value in the selection range).

Accuracy		Specifications
Reference accuracy		Within 0.04%
Temperature coefficient	Pt100/JPt100 (-20 to 120°C)	±70ppm/°C (±0.0070%/°C)
	Pt100/JPt100 (0 to 200°C)	±65ppm/°C (±0.0065%/°C)
	Pt100/JPt100 (-200 to 850°C)	±50ppm/°C (±0.0050%/°C)
	Ni100Ω (-60 to 180°C)	±70ppm/°C (±0.0070%/°C)

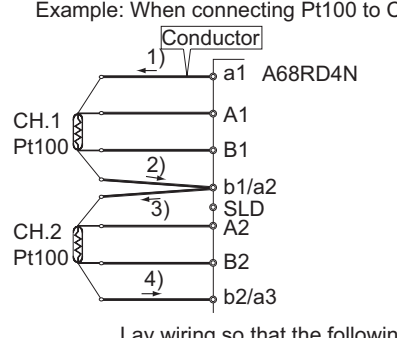
Item	A68RD4N	
Cable across module - platinum resistance thermometer	<p>Set the total resistance value of a conductor where the current runs to 70Ω or less.</p> <p>Example: When connecting Pt100 to CH1 and CH2</p>  <p>Lay wiring so that the following condition is met. $1) + 2) + 3) + 4) \leq 70 (\Omega)$ ← indicates the direction of current.</p>	
Internal current consumption (5VDC)	0.41A	
Weight	0.43kg	

○ : Compatible, △ : Partial change required, × : Incompatible

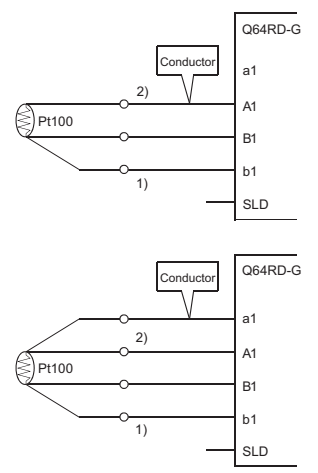
	Q64RD-G	Compatibility	Precautions for replacement
	<p>The conductor resistance value must meet the condition of $1) + 2) \leq 2k\Omega$ or less. (In the case of 3-conductor type, the difference between 1) and 2) in the conductor resistance value must be 10Ω or less.)</p> 	○	
	0.62A	△	The recalculation of internal current consumption (5VDC) is required.
	0.20kg	○	

4.8.2 Functional comparison

○ : Available, - : Not available

Item	Description	A68RD4N	Q64RD-G	Precautions for replacement
Conversion enable/disable specification of each channel	Enables/disables a detection of temperature.	○	○	
Sampling/averaging processing selection	Processes the detected temperature by specified method.	○	○	The setting ranges of time and count averages differ. Refer to the RTD Input Module/ Channel Isolated RTD Input Module User's Manual to check the specifications.
Detected temperature value storage	Stores temperature data in the buffer memory.	○	○	
Disconnection detection	Detects a disconnection of the connected RTD or cable.	○	○	For the Q64RD-G, a disconnection is detected per channel.
Type specification of RTD	Specifies a RTD type used.	○	○	
Range switching function	Switches the measured temperature range.	-	○	
Warning output function	Outputs a warning when the temperature exceeds the set temperature range.	-	○	
Scaling function	Converts a measured temperature value into a percent value (%) in set width.	-	○	
Error correction function	Corrects an error in temperature conversion value.	○	○	Perform the error correction by the offset/gain setting of the Q64RD-G.
Online module replacement	Replaces a module without stopping the system.	-	○	Replaceable modules during online are the Process CPU and the Redundant CPU.

4.8.3 I/O signal comparison to programmable controller CPU

Sequence program change is required as the I/O signals differ.

For details of the I/O signals and sequence program, refer to the RTD Input Module/Channel Isolated RTD Input Module User's Manual.

A68RD4N				Q64RD-G				
Device No.	Signal name	Device No.	Signal name	Device No.	Signal name	Device No.	Signal name	
X0	Watchdog timer error flag	Y0	Not used	X0	Module READY	Y0	Not used	
X1	READY flag	Y1		X1	CH1 Offset/gain setting status signal	Y1	CH1 Offset setting request	
X2	Write data error flag	Y2		X2	CH2 Offset/gain setting status signal	Y2	CH1 Gain setting request	
X3	Σ disconnection detection flag (CH1 to CH8)	Y3		X3	CH3 Offset/gain setting status signal	Y3	CH2 Offset setting request	
X4	Not used	Y4		X4	CH4 Offset/gain setting status signal	Y4	CH2 Gain setting request	
X5		Y5		X5	Not used	Y5	CH3 Offset setting request	
X6		Y6		X6		Y6	CH3 Gain setting request	
X7		Y7		X7		Y7	CH4 Offset setting request	
X8		Y8		X8		Y8	CH4 Gain setting request	
X9		Y9		X9	Operating condition setting completion signal	Y9	Operating condition setting request	
XA		YA		XA	Offset/gain setting mode status flag	YA	User range write request	
XB		YB		XB	Not used	YB	Not used	
XC		YC		XC	Disconnection detection signal	YC		
XD		YD		XD	Interlock signal for the RFRP and RTOP instructions when the A68RD4N is used in remote I/O station	YD		Warning output signal
XE	YE	XE	Not used	YE	Conversion completion flag			
XF	YF	XF		Error flag	YF	Error clear request		
X10	Not used	Y10	Not used					
X11		Y11						
X12		Y12		Error code reset flag				
X13		Y13						
X14		Y14						
X15		Y15						
X16		Y16						
X17		Y17						
X18		Y18						
X19		Y19						
X1A	Y1A	Not used						
X1B	Y1B							
X1C	Y1C							
X1D	Y1D	Interlock signal for the RFRP and RTOP instructions when the A68RD4N is used in remote I/O station						
X1E	Y1E							
X1F	Y1F							

4.8.4 Buffer memory address comparison

Sequence program change is required as the assignment of buffer memory differs.

For details of the buffer memory and sequence program, refer to the RTD Input Module/Channel Isolated RTD Input Module User's Manual.

A68RD4N			Q64RD-G			
Address (decimal)	Name	Read/write	Address (decimal)	Name	Read/write	
0	Conversion enable/disable specification	R/W	0	Conversion enable/disable setting	R/W	
1	Averaging processing selection		1	CH1 Time/count/moving average/time constant setting		
2	CH1 Averaging time/count		2	CH2 Time/count/moving average/time constant setting		
3	CH2 Averaging time/count		3	CH3 Time/count/moving average/time constant setting		
4	CH3 Averaging time/count		4	CH4 Time/count/moving average/time constant setting		
5	CH4 Averaging time/count		5	System area		
6	CH5 Averaging time/count		to			
7	CH6 Averaging time/count		8			
8	CH7 Averaging time/count		R	9		Averaging processing selection
9	CH8 Averaging time/count	10		Conversion completion flag	R	
10	CH1 Detected temperature value (16bit)	11		CH1 Measured temperature value (16bit)		
11	CH2 Detected temperature value (16bit)	12		CH2 Measured temperature value (16bit)		
12	CH3 Detected temperature value (16bit)	13		CH3 Measured temperature value (16bit)		
13	CH4 Detected temperature value (16bit)	-		14	CH4 Measured temperature value (16bit)	
14	CH5 Detected temperature value (16bit)			15	System area (Not used)	
15	CH6 Detected temperature value (16bit)			to		
16	CH7 Detected temperature value (16bit)			18		
17	CH8 Detected temperature value (16bit)		19	Error code	R	
18	CH1 Detected temperature value (L)		20	Setting range 1		
19	(32bit) (H)		21	Setting range 2		
20	CH2 Detected temperature value (L)		-	22	System area (Not used)	
21	(32bit) (H)			23		
22	CH3 Detected temperature value (L)	24				
23	(32bit) (H)	25				
24	CH4 Detected temperature value (L)	26				
25	(32bit) (H)	27				
26	CH5 Detected temperature value (L)	28				
27	(32bit) (H)	29				
28	CH6 Detected temperature value (L)	30				
29	(32bit) (H)	31				
30	CH7 Detected temperature value (L)	32				
31	(32bit) (H)	33				
32	CH8 Detected temperature value (L)	34		Write data error code		R/W
33	(32bit) (H)	35		Conversion completion flag		R
34	Write data error code	36		Specification of platinum RTD type		R/W
35	Conversion completion flag	37				
36	Specification of platinum RTD type	38				

Q64RD-G		
Address (decimal)	Name	Read/write
39	System area (Not used)	-
40		
41		
42		
43		
44		
45		
46		
47	Warning output enable/disable setting	R/W
48	Warning output flag	R
49	Disconnection detection flag	
50 to 53	CH1 to CH4 Scaling value	
54	CH1 Measured temperature (L)	R
55	value (32bit) (H)	
to		
60	CH4 Measured temperature (L)	R
61	value (32bit) (H)	
62	CH1 Scaling range lower limit value (L)	R/W
63	(H)	
64	CH1 Scaling range upper limit value (L)	
65	(H)	
to		
76	CH4 Scaling range upper limit (L)	R/W
77	value (H)	
78	CH1 Scaling width lower limit value	
79	CH1 Scaling width upper limit value	
to		
85	CH4 Scaling width upper limit value	R/W
86	CH1 Warning output lower lower (L)	
87	limit value (H)	
88	CH1 Warning output lower upper (L)	
89	limit value (H)	
90	CH1 Warning output upper lower (L)	
91	limit value (H)	
92	CH1 Warning output upper upper (L)	
93	limit value (H)	
to		
116	CH4 Warning output upper upper (L)	R/W
117	limit value (H)	
118	CH1 Offset temperature setting value (L)	
119	(H)	
120	CH1 Gain temperature setting value (L)	
121	(H)	
to		
132	CH4 Gain temperature setting value (L)	R/W
133	(H)	
134	Extended averaging processing selection	
135 to 147	System area (Not used)	-
148	Conversion setting for disconnection detection	R/W
149	System area (Not used)	-
150	CH1 Conversion setting value for (L)	R/W
151	disconnection detection (H)	

Q64RD-G			
Address (decimal)	Name	Read/write	
to			
156	CH4 Conversion setting value for (L)	R/W	
157	disconnection detection (H)		
158	Mode switching setting		
159			
160	3-conductor type CH1 Factory default (L)		
161	offset value (H)		
162	3-conductor type CH1 Factory default (L)		
163	gain value (H)		
164	3-conductor type CH1 User range (L)		
165	settings offset value (H)		
166	3-conductor type CH1 User range (L)		
167	settings gain value (H)		
168	3-conductor type CH1 User range (L)		
169	settings offset resistance value (H)		
170	3-conductor type CH1 User range (L)		
171	settings gain resistance value (H)		
172	4-conductor type CH1 Factory default (L)		
173	offset value (H)		
174	4-conductor type CH1 Factory default (L)		
175	gain value (H)		
176	4-conductor type CH1 User range (L)		
177	settings offset value (H)		
178	4-conductor type CH1 User range (L)		
179	settings gain value (H)		
180	4-conductor type CH1 User range (L)		
181	settings offset resistance value (H)		
182	4-conductor type CH1 User range (L)		
183	settings gain resistance value (H)		
to			
254	4-conductor type CH4 User range (L)	R/W	
255	settings gain resistance value (H)		

5 MULTIPLEXER REPLACEMENT

The multiplexer module is designed especially for channel extension of the analog-digital converter module A616AD.

Analog input signals (voltage/current) taken by the multiplexer module are output as analog output signals (voltage) to the A616AD.

For this reason, the I/O characteristics and the maximum resolution of the multiplexer module are adjusted to be the same as the voltage input specifications of the A616AD.

Check the set range in each channel of the existing multiplexer module to estimate the I/O characteristics and the maximum resolution.

5.1 A60MX

As regarding A60MX non-isolated multiplexer module, consider replacement using multiple Q68ADV/I.

5.1.1 Performance comparison

Item		A60MX		
Analog input	Voltage	-10 to 0 to +10VDC (Input resistance value: 1MΩ)		
	Current	-20 to 0 to +20mADC (Input resistance value: 250Ω)		
Analog output voltage		-10 to 0 to +10VDC		
I/O characteristics	Analog input range		Analog output voltage (V) ^{*1}	
	Voltage (V)	Current (mA)		
	0 to +10	0 to +20	0 to +10	
	0 to +5	0 to +20		
	+ 1 to + 5	+ 4 to +20		
	-10 to +10	-20 to +20		
	- 5 to + 5	-20 to +20	0 to + 5	
	0 to +10	0 to +20		
	0 to + 5	0 to +20		
	+ 1 to + 5	+ 4 to +20	+ 1 to + 5	
	-10 to +10	-20 to +20	-10 to +10	
	- 5 to + 5	-20 to +20		
	-10 to +10	-20 to +20		
- 5 to + 5	-20 to +20	- 5 to + 5		

○ : Compatible, △ : Partial change required, × : Incompatible

		Q68ADV		Q68ADI		Compatibility	Precautions for replacement		
		-10 to 10VDC (Input resistance value: 1MΩ)		-		△	The voltage/current cannot be mixed for one module.		
		-		0 to 20mADC (Input resistance value: 250Ω)					
		-		-		-	Analog output voltage to the A616AD		
		Analog input range		Normal resolution mode		High resolution mode			
				Digital output value	Maximum resolution	Digital output value	Maximum resolution		
Voltage	0 to 10V	0 to 4000	2.5mV	0 to 16000	0.625mV	0 to 12000	0.416mV		
	0 to 5V							1.0mV	0.333mV
	1 to 5V								
	-10 to 10V	-4000 to 4000	2.5mV	-16000 to 16000	0.625mV				
User range settings	0.375mV		-12000 to 12000	0.333mV					
Current	0 to 20mA	0 to 4000	5μA	0 to 12000	1.66μA	-12000 to 12000	1.33μA		
	4 to 20mA		4μA		1.33μA				
	User range settings	-4000 to 4000	1.37μA	1.33μA					
						△	When using A616AD in [-5 to +5V] range, Q68ADV can obtain equivalent resolution or more than A616AD by setting in [-10 to 10V] range/high resolution mode or user range. When using A616AD in [-20 to +20mA] range, use Q68ADI in user range.		

Item		A60MX
Overall accuracy		±0.3% (Digital output value ±12)
Absolute maximum input	Voltage	±15V
	Current	±30mA
Analog input points		16 channels/module
Multiplexer element		IC relay
Isolation method		Between the input terminal and programmable controller: photocoupler isolation Between channels: non-isolated (1MΩ resistor isolation)
Occupied I/O points		16 points (treated as empty slots) (0 point setting is possible by I/O assignment.)
Connected terminal		38-point terminal block
Applicable wire size		0.75 to 2mm ² (Applicable tightening torque: 39 to 59N•cm)
Applicable solderless terminal		V1.25-3, V1.25-YS3A, V2-S3, V2-YS3A
Internal current consumption (5VDC)		0.65A
Weight		0.55kg

○ : Compatible, △ : Partial change required, × : Incompatible

Q68ADV		Q68ADI			Compatibility	Precautions for replacement	
Analog input range	Normal resolution mode			High resolution mode			
	Ambient temperature 0 to 55°C		Ambient temperature 25±5°C	Ambient temperature 0 to 55°C		Ambient temperature 25±5°C	
	With temperature drift compensation	Without temperature drift compensation		With temperature drift compensation	Without temperature drift compensation		
Voltage	0 to 10V	±0.3% (±12 digits)	±0.4% (±16 digits)	±0.1% (±4 digits)	±0.3% (±36 digits)	±0.4% (±48 digits)	±0.1% (±16 digits)
	-10 to 10V						
	0 to 5V						
	1 to 5V						
Current	Users range settings						
	0 to 20mA						
	4 to 20mA						
	Users range settings						
±15V		-			○		
-		±30mA					
8 channels/module					△	Consider replacement with multiple Q68ADV/I.	
-					-		
Between the I/O terminal and programmable controller power supply: photocoupler isolation Between channels: non-isolated					○		
16 points (I/O assignment: intelligent 16 points)					△	Q68ADV/I cannot set to 0 point with I/O assignment.	
18-point terminal block					×	Wiring change is required.	
0.3 to 0.75mm ²					×		
R1.25-3 (A solderless terminal with sleeve can not be used.)					×		
0.64A		0.64A			○		
0.19kg		0.19kg			○		

*1 Analog output (voltage) to the A616AD, processing analog input values of the A60MX.
The I/O characteristics and the maximum resolution are to be the same as in the specifications of the A616AD as below.

Input	Analog input range	Maximum resolution	Digital output value
Voltage (V)	0 to +10	2.5mV (1/4000)	0 to 4000 -2000 to 2000
	0 to +5	1.25mV (1/4000)	
	+1 to +5	1.0mV (1/4000)	
	-10 to +10	5.0mV (1/4000)	
	-5 to +5	2.5mV (1/4000)	
Current (mA)	0 to +20	10μA (1/2000)	0 to 2000 -2000 to 0
	0 to +20	5μA (1/4000)	0 to 4000
	+4 to +20	4μA (1/4000)	-2000 to 2000
	-20 to +20	20μA (1/2000)	1000 to 3000 -1000 to 1000
	-20 to +20	10μA (1/4000)	0 to 4000 -2000 to 2000

5.2 A60MXRN

As regarding A60MXRN non-isolated multiplexer module, consider replacement using multiple Q64AD-GH.

5.2.1 Performance comparison

Item		A60MXRN	
Analog input	Voltage	-10 to 0 to +10VDC (Input resistance value: 1MΩ)	
	Current	-20 to 0 to +20mADC (Input resistance value: 250Ω)	
Analog output voltage		-10 to 0 to +10VDC	
I/O characteristics	Analog input range		Analog output voltage (V) ^{*1}
	Voltage (V)	Current (mA)	
	0 to +10	0 to +20	0 to +10
	0 to +5	0 to +20	
	+1 to +5	+4 to +20	
	-10 to +10	-20 to +20	
	-5 to +5	-20 to +20	
	0 to +10	0 to +20	0 to +5
	0 to +5	0 to +20	+1 to +5
	+1 to +5	+4 to +20	
	-10 to +10	-20 to +20	
	-5 to +5	-20 to +20	-10 to +10
	-10 to +10	-20 to +20	-5 to +5
-5 to +5	-20 to +20		
Overall accuracy		±0.3% (Digital output value ±12)	
Absolute maximum input	Voltage	±15V	
	Current	±30mA	
Analog input points		16 channels/module	
Multiplexer element		Photo MOS relay	
Isolation method		Between the input terminal and programmable controller: photocoupler isolation Between channels: photo MOS relay isolation	
Between channels dielectric withstand voltage		400VDC (accuracy guarantee 400VDC)	
Occupied I/O points		16 points (treated as empty slots) (0 point setting is possible by I/O assignment.)	
Connected terminal		38-point terminal block	
Applicable wire size		0.75 to 2mm ² (Applicable tightening torque: 39 to 59N•cm)	
Applicable solderless terminal		V1.25-3, V1.25-YS3A, V2-S3, V2-YS3A	
Internal current consumption (5VDC)		0.35A	
Weight		0.56kg	

○: Compatible, △: Partial change required, ×: Incompatible

Q64AD-GH					Compatibility	Precautions for replacement
-10 to 0 to +10VDC (Input resistance value: 1MΩ)					○	
0 to 20mADC (Input resistance value: 250Ω)					△	The minus current cannot be input.
-					-	Analog output voltage to the A616AD
Input	Analog input range	Maximum resolution		Digital output value (32 bit)	Digital output value (16 bit)	△ When using a range of -5 up to +5 (with A60MX), With Q64AD-GH, equivalent or more resolution value can be obtained by setting at a range of -10 up to 10V/high resolution mode, or user range. When using a range of -20 up to +20mA (with A60MX), negative current can not be converted with Q64AD-GH. Use conversion devices to convert into a input range.
Voltage	0 to 10V	156.3μV	312.6μV	0 to 64000	0 to 32000	
	0 to 5V	78.2μV	156.4μV			
	1 to 5V	62.5μV	125.0μV			
	User range settings (Uni-polar)	47.4μV	94.8μV	-64000 to 64000	-32000 to 32000	
	User range settings (Bi-polar)	156.3μV	312.6μV			
Current	0 to 20mA	312.5nA	625.0nA	0 to 64000	0 to 32000	
4 to 20mA	250.0nA	500.0nA				
User range settings (Uni-polar)	151.6nA	303.2nA				
Reference accuracy	±0.05% Digital output value (32 bit) ±32 digits Digital output value (16 bit) ±16 digits				○	A60MXRN is the accuracy in respect to the full scale, and Q64AD-GH is the accuracy in respect to maximum digital output value.
Temperature coefficient	±71.4ppm/°C (0.00714%/°C)					
±15V					○	
±30mA					○	
4 channels/module					△	Consider replacement with multiple Q64AD-GH.
-					-	
Specific isolated area		Isolation method	Dielectric withstand voltage	Insulation resistance		○
Between the I/O terminal and programmable controller power supply		Photocoupler isolation	1780VrmsAC/3 cycles (Altitude 2000m)	500V DC, 10MΩ or more		
Between analog channels		Transformer isolation				
16 points (I/O assignment: intelligent 16 points)					△	Q64AD-GH cannot set to 0 point with I/O assignment.
18-point terminal block					×	Wiring change is required.
0.3 to 0.75mm ²					×	
R1.25-3 (A solderless terminal with sleeve can not be used.)					×	
0.89A					△	The recalculation of internal current consumption [5VDC] is required.
0.2kg					○	

*1 Analog output (voltage) to the A616AD, processing analog input values of the A60MX.
The I/O characteristics and the maximum resolution are to be the same as in the specifications of the A616AD as below.

Input	Analog input range	Maximum resolution	Digital output value
Voltage (V)	0 to +10	2.5mV (1/4000)	0 to 4000 -2000 to 2000
	0 to +5	1.25mV (1/4000)	
	+1 to +5	1.0mV (1/4000)	
	-10 to +10	5.0mV (1/4000)	
	-5 to +5	2.5mV (1/4000)	

5.3 A60MXR

As regarding A60MXR non-isolated multiplexer module, consider replacement using multiple Q64AD-GH.

5.3.1 Performance comparison

Item		A60MXR	
Analog input	Voltage	-10 to 0 to +10VDC (Input resistance value: 1MΩ)	
	Current	-20 to 0 to +20mADC (Input resistance value: 250Ω)	
Analog output voltage		-10 to 0 to +10VDC	
I/O characteristics	Analog input range		Analog output voltage (V) ^{*1}
	Voltage (V)	Current (mA)	
	0 to +10	0 to +20	0 to +10
	0 to +5	0 to +20	
	+1 to +5	+4 to +20	
	-10 to +10	-20 to +20	
	-5 to +5	-20 to +20	
	0 to +10	0 to +20	0 to +5
	0 to +5	0 to +20	+1 to +5
	+1 to +5	+4 to +20	
	-10 to +10	-20 to +20	
	-5 to +5	-20 to +20	-10 to +10
	-10 to +10	-20 to +20	-5 to +5
-5 to +5	-20 to +20		
Overall accuracy		±0.3% (Digital output value ±12)	
Absolute maximum input	Voltage	±15V	
	Current	±30mA	
Analog input points		16 channels/module	
Multiplexer element		Mercury plunger relay	
Isolation method		Between the input terminal and programmable controller: photocoupler isolation Between channels: mercury plunger relay isolation	
Between channels dielectric withstand voltage		500VDC (accuracy guarantee 500VDC)	
Occupied I/O points		16 points (treated as empty slots) (0 point setting is possible by I/O assignment.)	
Connected terminal		38-point terminal block	
Applicable wire size		0.75 to 2mm ² (Applicable tightening torque: 39 to 59N•cm)	
Applicable solderless terminal		V1.25-3, V1.25-YS3A, V2-S3, V2-YS3A	
Internal current consumption (5VDC)		0.5A	
Weight		0.6kg	

○: Compatible, △: Partial change required, ×: Incompatible

Q64AD-GH					Compatibility	Precautions for replacement
-10 to 0 to +10VDC (Input resistance value: 1MΩ)					○	
0 to 20mADC (Input resistance value: 250Ω)					△	The minus current cannot be input.
-					-	Analog output voltage to the A616AD
Input	Analog input range	Maximum resolution		Digital output value (32 bits)	Digital output value (16 bits)	△ With A60MXR, equivalent or more resolution value can be obtained by setting at the analog inputs, range of -10 up to 10V/high resolution mode, and User range while the analog inputs are used at the range of -5 up to 5V on Q64AD-GH. When using a range of -20 up to +20mA (with A60MXR), negative current can not be converted with Q64AD-GH. Use conversion devices to convert into a input range.
Voltage	0 to 10V	156.3μV	312.6μV	0 to 64000	0 to 32000	
	0 to 5V	78.2μV	156.4μV			
	1 to 5V	62.5μV	125.0μV			
	User range settings (Uni-polar)	47.4μV	94.8μV	-64000 to 64000	-32000 to 32000	
	-10 to 10V	156.3μV	312.6μV			
User range settings (Bi-polar)	47.4μV	94.8μV				
Current	0 to 20mA	312.5nA	625.0nA	0 to 64000	0 to 32000	
	4 to 20mA	250.0nA	500.0nA			
	User range settings (Uni-polar)	151.6nA	303.2nA			
Reference accuracy	±0.05% Digital output value (32 bit) ±32 digits Digital output value (16 bit) ±16 digits				○	A60MXR is the accuracy in respect to the full scale, and Q64AD-GH is the accuracy in respect to maximum digital output value.
Temperature coefficient	±71.4ppm/°C (0.00714%/°C)					
±15V					○	
±30mA					○	
4 channels/module					△	Consider replacement with multiple Q64AD-GH.
-					-	
Specific isolated area	Isolation method	Dielectric withstand voltage	Insulation resistance	○		
Between the I/O terminal and programmable controller power supply	Photocoupler isolation	1780VrmsAC/3 cycles (Altitude 2000m)	500VDC, 10MΩ or more			
Between analog channels	Transformer isolation					
16 points (I/O assignment: intelligent 16 points)					△	Q64AD-GH cannot set to 0 point with I/O assignment.
18-point terminal block					×	Wiring change is required.
0.3 to 0.75mm ²					×	
R1.25-3 (A solderless terminal with sleeve can not be used.)					×	
0.89A					△	The recalculation of internal current consumption [5VDC] is required.
0.2kg					○	

*1 Analog output (voltage) to the A616AD, processing analog input values of the A60MX.
 The I/O characteristics and the maximum resolution are to be the same as in the specifications of the A616AD as below.

Input	Analog input range	Maximum resolution	Digital output value
Voltage (V)	0 to +10	2.5mV (1/4000)	0 to 4000 -2000 to 2000
	0 to +5	1.25mV (1/4000)	
	+1 to +5	1.0mV (1/4000)	
	-10 to +10	5.0mV (1/4000)	
	-5 to +5	2.5mV (1/4000)	

6 HIGH-SPEED COUNTER MODULE REPLACEMENT

6.1 List of High-Speed Counter Module Alternative Models for Replacement

Production discontinuation		Transition to Q series	
Product	Model	Model	Remarks (Restrictions)
High-speed counter module	AD61	QD62-H01*1	1) External wiring : Terminal block wiring → Connector wiring Cable size is changed. 2) Number of slots : Not changed 3) Counting speed : Not changed 4) Counting range : 24-bit unsigned binary (0 to 16777215) → 32-bit signed binary (–2147483648 to 2147483647) Review the program. 5) Program : Occupied I/O points, I/O signals and buffer memory address are changed. 6) Performance specifications change: Not changed 7) Function specifications: Not changed
	AD61-S1	QD62-H02*1	1) External wiring : Terminal block wiring → Connector wiring Cable size is changed. 2) Number of slots : Not changed 3) Counting speed : Not changed 4) Counting range : 24-bit unsigned binary (0 to 16777215) → 32-bit signed binary (–2147483648 to 2147483647) Review the program. 5) Program : Occupied I/O points, I/O signals and buffer memory address are changed. 6) Performance specifications change: Not changed 7) Function specifications: Not changed

*1 The QD62-H01 is a module dedicated for replacing the AD61 with the Q series module.
 The QD62-H02 is a module dedicated for replacing the AD61-S1 with the Q series module.
 Both of them have same input filter system with the AD61 and AD61-S1.

☒ Point

- 1) Action to the replaced module
Input filter system of the AD61 and AD61-S1 is the same as that of the QD62-H01 and QD62-H02. Therefore, utilizing pulse generator such as existing encoder is possible.
- 2) Counting range of the counter
Counting range of the AD61 and AD61-S1 differs from that of the QD62-H01 and QD62-H02. To make the counting range same as that of the module before replacement, review the program.
AD61, AD61-S1: 0 to 16, 777, 215 (24-bit unsigned binary)
QD62-H01, QD62-H02: - 2, 147, 483, 648 to 2, 147, 483, 647 (32-bit signed binary)
- 3) Wiring to the module
External wiring method of the AD61 and AD61-S1 differs from that of the QD62-H01 and QD62-H02.
AD61, AD61-S1: Wiring using a terminal block
QD62-H01, QD62-H02: Wiring using a connector
- 4) In module replacement, continuous use of the I/O signal wire with solderless terminal that has been used for the AD61 or AD61-S1 requires the change of the external wiring method as in (a) (b).
 - (a) Using the upgrade tool (a conversion adaptor)
The existing wiring for AD61 and AD61-S1 can be connected directly to the Q series modules using the upgrade tool, a conversion adaptor, manufactured by Mitsubishi Electric Engineering Co., Ltd.

Product	MELSEC-A/QnA series module	MELSEC-Q series module	Conversion adaptor
High-speed counter module	AD61	QD62	ERNT-AQTD61
		QD62-H01	
	AD61-S1	QD62-H02	

- (b) For contact information for inquiries on the upgrade tool manufactured by Mitsubishi Electric Engineering Co., Ltd., refer to Section 2.1.

(c) Using the connector/terminal block converter module

Used for replacement when the Q series large type base unit and conversion adapters manufactured by Mitsubishi Electric Engineering Co., Ltd. cannot be used due to the restrictions such as a system configuration and an installation location.

I/O cables with solderless terminal of the existing module can be continuously used without being aware of the existing wire size by rewiring the I/O cables with solderless terminal to the connector/terminal block converter module and connecting them by dedicated cables. This method, therefore, is helpful when there is not a sufficient space. The following figure shows the wiring method for using the connector/terminal block converter module.

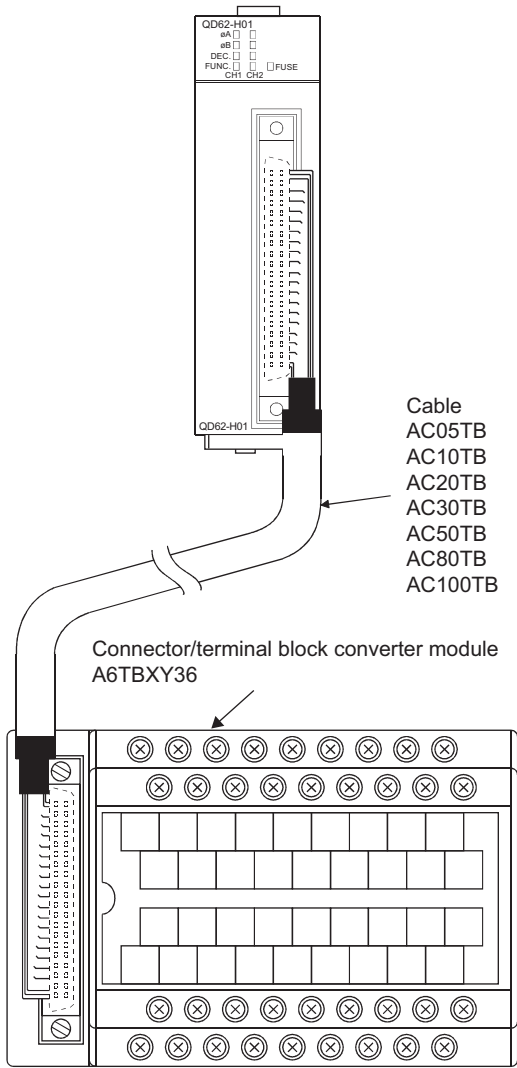

	Signal name	Terminal number on connector side	Terminal symbol on terminal block side
CH1	A phase pulse input 24V	A20	10
	A phase pulse input 12V	B20	0
	A phase pulse input 5V	A19	11
	ABCOM	B19	1
	B phase pulse input 24V	A18	12
	B phase pulse input 12V	B18	2
	B phase pulse input 5V	A17	13
	Preset input 24V	B17	3
	Preset input 12V	A16	14
	Preset input 5V	B16	4
	CTRLCOM	A15	15
	Function start 24V	B15	5
	Function start 12V	A14	16
	Function start 5V	B14	6
CH2	EQU (coincidence output point No.1)	A06	1E
	EQU (coincidence output point No.2)	B06	E
	A phase pulse input 24V	A13	17
	A phase pulse input 12V	B13	7
	A phase pulse input 5V	A12	18
	ABCOM	B12	8
	B phase pulse input 24V	A11	19
	B phase pulse input 12V	B11	9
	B phase pulse input 5V	A10	1A
	Preset input 24V	B10	A
	Preset input 12V	A09	1B
	Preset input 5V	B09	B
	CTRLCOM	A08	1C
	Function start 24V	B08	C
Function start 12V	A07	1D	
Function start 5V	B07	D	
EQU (coincidence output point No.1)	A05	1F	
EQU (coincidence output point No.2)	B05	F	
12/24V		B02	24V
		B01	
0V		A02	0V
		A01	

6.2 AD61

6.2.1 Performance comparison

○ : Compatible, △ : Partial change required, × : Incompatible

Item		AD61		QD62-H01		Compat- ibility	Precautions for replacement	
Occupied I/O points		32 points (I/O assignment: special 32 points)		16 points (I/O assignment: intelligent 16 points)		△	*1	
Number of channels		2 channels				○		
Counting speed switch settings		-		50KPPS		○	Set "2" at the intelligent function module switch setting.	
Performance specifications of 1 channels	Count input signal	Phase				1-phase input, 2-phase input		○
		Signal level (φA, φB)				5VDC 12VDC 24VDC } 2 to 5mA		○
	Counter	Counting speed (Max.)	1-phase input	50KPPS	1-phase input	50KPPS	○	*2
			2-phase input	50KPPS	2-phase input	50KPPS		
		Counting range	24-bit unsigned binary (0 to 16,777,215)		32-bit signed binary (-2147483648 to 2147483647)		△	On QD62-H01, as the value is used with 32-bit signed binary values, change of sequence program is required.
		Type	UP/DOWN preset counter + ring counter function				○	
	Minimum count pulse width (set input rise time to 5μs or less. Duty ratio: 50%)	<p style="text-align: center;">(1,2 phase input)</p>				○		
	Magnitude comparison between CPU and AD61/QD62-H01	Comparison range	24-bit unsigned binary		32-bit signed binary		○	
		Comparison result	Set value < count value Set value = count value Set value > count value				○	
	External input	Preset	12/24VDC, 3/6mA 5VDC, 5mA		5/12/24VDC, 2 to 5mA		△	On QD62-H01, as the external input specifications differ, confirm the external devices specifications.
Count disable		12/24VDC, 3/6mA 5VDC, 5mA		-				
Function start		-		5/12/24VDC, 2 to 5mA				
External output	Coincidence output	Transistor (open collector) output 12/24VDC, 0.5A		Transistor (sink type) output 2 points/channel 12/24VDC, 0.5A/point, 2A/common		○		
Internal current consumption (5VDC)		0.3A		0.3A		○		
Weight		0.5kg		0.11kg		○		

- *1 I/O numbers of the modules mounted to the right of the QD62-H01 change, because the number of I/O occupied points for the AD61 are different from the QD62-H01. Set the start I/O number for the module mounted to the right of the QD62-H01 to the same number for the module before the replacement in the I/O assignment tab of the Q parameter setting window. The program for the module before the replacement can be used.
- *2 The rise/fall time of a pulse affects the counting speed. Countable counting speeds are as follows.
Counting a pulse greater than $t = 50\mu\text{s}$ may result in a miscount.
 - For the AD61 and QD62-H01 (common for 1-phase input and 2-phase input)

Rise/fall time	Common to 1-phase input and 2-phase input
$t = 5\mu\text{s}$	50KPPS
$t = 50\mu\text{s}$	5KPPS

$t = 5\mu\text{s}$: 50KPPS
 $t = 50\mu\text{s}$: 5KPPS

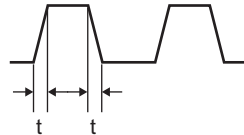

6.2.2 Function comparison

○ : With functions, - : Without functions

Item	Description	AD61	QD62-H01	Precautions for replacement
Preset function	Changes the counter present value to a specified value.	○	○	
Disable function	Terminates counting.	○	○	
Ring counter function	Repeatedly executes counting between user's setting values.	○	○	On QD62-H01, the setting is carried out using intelligent function module switch setting.
Linear counter function	If the count exceeds the range, this function detects an overflow.	-	○	
Coincidence output function	Outputs signals when user's setting and the present values are matched.	○	○	No.1 and No.2 coincidence output points can be set for each channel.
Coincidence detection interrupt function	Generates an interrupt signal to the programmable controller CPU when coincidence is detected.	-	○	
Latch counter function	Latches the present value at the time a signal is input.	-	○	
Sampling counter function	Counts the pulse that was input during the sampling time set.	-	○	
Periodic pulse counter function	The function allows storing the present value in the periodic pulse count present value and the previous value in the periodic pulse count previous value for each period time set.	-	○	

6.2.3 I/O signal comparison to programmable controller CPU

Sequence program change is required as the I/O signals differ.

For details of the I/O signals or sequence program, refer to the High-Speed Counter Module User's Manual.

AD61				QD62-H01			
Device No.	Signal name	Device No.	Signal name	Device No.	Signal name	Device No.	Signal name
X0	CH1 Counter value greater	Y0	Not used	X0	Module READY	Y0	CH1 Coincidence signal No.1 reset command
X1	CH1 Counter value coincidence	Y1		X1	CH1 Counter value large (Point No.1)	Y1	CH1 Preset command
X2	CH1 Counter value less	Y2		X2	CH1 Counter value coincidence (Point No.1)	Y2	CH1 Coincidence signal enable command
X3	CH1 External preset request detection	Y3		X3	CH1 Counter value small (Point No.1)	Y3	CH1 Down count command
X4	CH2 Counter value greater	Y4		X4	CH1 External preset request detection	Y4	CH1 Count enable command
X5	CH2 Counter value coincidence	Y5		X5	CH1 Counter value large (Point No.2)	Y5	CH1 External preset detection reset command
X6	CH2 Counter value less	Y6		X6	CH1 Counter value coincidence (Point No.2)	Y6	CH1 Counter function selection start command
X7	CH2 External preset request detection	Y7		X7	CH1 Counter value small (Point No.2)	Y7	CH1 Coincidence signal No.2 reset command
X8		Y8		X8	CH2 Counter value large (Point No.1)	Y8	CH2 Coincidence signal No.1 reset command
X9		Y9		X9	CH2 Counter value coincidence (Point No.1)	Y9	CH2 Preset command
XA		YA		XA	CH2 Counter value small (Point No.1)	YA	CH2 Coincidence signal enable command
XB		YB		XB	CH2 External preset request detection	YB	CH2 Down count command
XC		YC		XC	CH2 Counter value large (Point No.2)	YC	CH2 Count enable command
XD		YD		XD	CH2 Counter value coincidence (Point No.2)	YD	CH2 External preset detection reset command
XE		YE		XE	CH2 Counter value small (Point No.2)	YE	CH2 Counter function selection start command
XF		YF		XF	Fuse broken detection flag	YF	CH2 Coincidence signal No.2 reset command
X10		Y10					CH1 Coincidence signal reset command
X11		Y11				CH1 Preset command	
X12	Not used	Y12				CH1 Coincidence signal output enable command	
X13		Y13				CH1 Down count command	
X14		Y14				CH1 Count enable	
X15		Y15				CH1 Present value read request	
X16		Y16				CH1 External preset detection reset command	
X17		Y17				CH2 Coincidence signal reset command	
X18		Y18				CH2 Preset command	
X19		Y19				CH2 Coincidence signal output enable command	
X1A		Y1A				CH2 Down count command	
X1B		Y1B				CH2 Count enable	
X1C		Y1C				CH2 Present value read request	
X1D		Y1D				CH2 External preset detection reset command	
X1E		Y1E				Not used	
X1F		Y1F					

6.2.4 Buffer memory address comparison

Sequence program change is required as the assignment of buffer memory differs.

For details of the buffer memory or sequence program, refer to the High-Speed Counter Module User's Manual.

AD61				QD62-H01						
Address (Dec.)		Name	Read/write	Address (Dec.)		Name		Read/write		
CH1	CH2			CH1	CH2					
1	33	Preset value write (Lower and middle)	W	0	32	Preset value setting	(L)	R/W		
(2)	(34)	Preset value write (Upper)		1	33		(H)			
3	35	Mode register	R/W	2	34	Present value	(L)	R		
4	36	Present value read (Lower and middle)	R	3	35		(H)			
(5)	(37)	Present value read (Upper)		R/W	4	36	Coincidence output point set No.1	(L)		
6	38	Set value read/write (Lower and middle)	5		37	(H)				
(7)	(39)	Set value read/write (Upper)	6		38	Coincidence output point set No.2	(L)			
			7		39		(H)			
Address in parentheses in the above table indicates the upper 8 bits of 24-bit data.				8	40	Overflow detection flag		R		
				9	41	Counter function selection setting		R/W		
				10	42	Sampling/periodic setting				
Address in parentheses in the above table indicates the upper 8 bits of 24-bit data.				11	43	Sampling/periodic counter flag		R		
				12	44	Latch count value			(L)	
				13	45				(H)	
				14	46	Sampling count value			(L)	
				15	47				(H)	
				16	48	Periodic pulse count previous value			(L)	
				17	49				(H)	
				18	50	Periodic pulse count present value			(L)	
				19	51				(H)	
				20	52	Ring counter minimum value			(L)	R/W
				21	53				(H)	
22	54	Ring counter maximum value	(L)							
23	55		(H)							
24	56	System area (Not used)								
to	to									
31	63									

6.3 AD61S1

6.3.1 Performance comparison

○ : Compatible, △ : Partial change required, ✕ : Incompatible

Item		AD61S1	QD62-H02	Compat- ibility	Precautions for replacement	
Occupied I/O points		32 points (I/O assignment: special 32 points)	16 points (I/O assignment: intelligent 16 points)	△	*1	
Number of channels		2 channels		○		
Counting speed switch settings		-	10KPPS	○	Set "2" at the intelligent function module switch setting.	
Performance specifications of 1 channels	Count input signal	Phase	1-phase input, 2-phase input		○	
		Signal level (φA, φB)	5VDC 12VDC 24VDC } 2 to 5mA		○	
	Counter	Counting speed (Max.)	1-phase input 10KPPS 2-phase input 7KPPS	1-phase input 10KPPS 2-phase input 7KPPS	○	*2
		Counting range	24-bit unsigned binary (0 to 16,777,215)	32-bit signed binary (-2147483648 to 2147483647)	△	On QD62-H02, as the value is used with 32-bit signed binary values, change of sequence program is required.
	Type	UP/DOWN preset counter + ring counter function		○		
	Minimum count pulse width (set input rise time to 5μs or less. Duty ratio: 50%)			○		
	Magnitude comparison between CPU and AD61/QD62-H02	Comparison range	24-bit unsigned binary	32-bit signed binary	○	
		Comparison result	Set value < count value Set value = count value Set value > count value		○	
	External input	Preset	12/24VDC, 3/6mA 5VDC, 5mA	5/12/24VDC, 2 to 5mA	△	On QD62-H02, as the external input specifications differ, confirm the external devices specifications.
		Count disable	12/24VDC, 3/6mA 5VDC, 5mA	-		
Function start		-	5/12/24VDC, 2 to 5mA			
External output	Coincidence output	Transistor (open collector) output 12/24VDC, 0.5A	Transistor (sink type) output 2 points/channel 12/24VDC, 0.5A/point, 2A/common	○		
Internal current consumption (5VDC)		0.3A	0.3A	○		
Weight		0.5kg	0.11kg	○		

- *1 I/O numbers of the modules mounted to the right of the QD62-H02 change, because the number of I/O occupied points for the AD61S1 are different from the QD62-H02. Set the start I/O number for the module mounted to the right of the QD62-H02 to the same number for the module before the replacement in the I/O assignment tab of the Q parameter setting window. The program for the module before the replacement can be used.
- *2 The rise/fall time of a pulse affects the counting speed. Countable counting speeds are as follows.
Counting a pulse whose rise/fall time is long may result in a miscount.
 - For the AD61S1 and QD62-H02

Rise/fall time	1-phase input	2-phase input
$t = 5\mu\text{s}$	10KPPS	7KPPS
$t = 500\mu\text{s}$	500PPS	250PPS

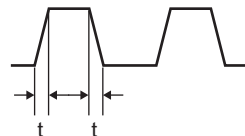

6.3.2 Function comparison

○: With functions, -: Without functions

Item	Description	AD61S1	QD62-H02	Precautions for replacement
Preset function	Changes the counter present value to a specified value.	○	○	
Disable function	Terminates counting.	○	○	
Ring counter function	Repeatedly executes counting between user's setting values.	○	○	On QD62-H02, the setting is carried out using intelligent function module switch setting.
Linear counter function	If the count exceeds the range, this function detects an overflow.	-	○	
Coincidence output function	Outputs signals when user and the present values are matched.	○	○	No.1 and No.2 coincidence output points can be set for each channel.
Coincidence detection interrupt function	Generates an interrupt signal to the programmable controller CPU when coincidence is detected.	-	○	
Latch counter function	Latches the present value at the time a signal is input.	-	○	
Sampling counter function	Counts the pulses that are input during the sampling time set.	-	○	
Periodic pulse counter function	The function allows storing the present value in the periodic pulse count present value and the previous value in the periodic pulse count previous value for each period time set.	-	○	

6.3.3 I/O signal comparison to programmable controller CPU

Sequence program change is required as the I/O signals differ.

For details of the I/O signals or sequence program, refer to the High-Speed Counter Module User's Manual.

AD61S1				QD62-H02				
Device No.	Signal name	Device No.	Signal name	Device No.	Signal name	Device No.	Signal name	
X0	CH1 Counter value greater	Y0	Not used	X0	Module READY	Y0	CH1 Coincidence signal No.1 reset command	
X1	CH1 Counter value coincidence	Y1		X1	CH1 Counter value large (Point No.1)	Y1	CH1 Preset command	
X2	CH1 Counter value less	Y2		X2	CH1 Counter value coincidence (Point No.1)	Y2	CH1 Coincidence signal enable command	
X3	CH1 External preset request detection	Y3		X3	CH1 Counter value small (Point No.1)	Y3	CH1 Down count command	
X4	CH2 Counter value greater	Y4		X4	CH1 External preset request detection	Y4	CH1 Count enable command	
X5	CH2 Counter value coincidence	Y5		X5	CH1 Counter value large (Point No.2)	Y5	CH1 External preset detection reset command	
X6	CH2 Counter value less	Y6		X6	CH1 Counter value coincidence (Point No.2)	Y6	CH1 Counter function selection start command	
X7	CH2 External preset request detection	Y7		X7	CH1 Counter value small (Point No.2)	Y7	CH1 Coincidence signal No.2 reset command	
X8		Y8		X8	CH2 Counter value large (Point No.1)	Y8	CH2 Coincidence signal No.1 reset command	
X9		Y9		X9	CH2 Counter value coincidence (Point No.1)	Y9	CH2 Preset command	
XA		YA		XA	CH2 Counter value small (Point No.1)	YA	CH2 Coincidence signal enable command	
XB		YB		XB	CH2 External preset request detection	YB	CH2 Down count command	
XC		YC		XC	CH2 Counter value large (Point No.2)	YC	CH2 Count enable command	
XD		YD		XD	CH2 Counter value coincidence (Point No.2)	YD	CH2 External preset detection reset command	
XE		YE		XE	CH2 Counter value small (Point No.2)	YE	CH2 Counter function selection start command	
XF		YF		XF	Fuse broken detection flag	YF	CH2 Coincidence signal No.2 reset command	
X10	Not used	Y10		CH1 Coincidence signal reset command				
X11		Y11		CH1 Preset command				
X12		Y12	CH1 Coincidence signal output enable command					
X13		Y13	CH1 Down count command					
X14		Y14	CH1 Count enable					
X15		Y15	CH1 Present value read request					
X16		Y16	CH1 External preset detection reset command					
X17		Y17	CH2 Coincidence signal reset command					
X18		Y18	CH2 Preset command					
X19		Y19	CH2 Coincidence signal output enable command					
X1A		Y1A	CH2 Down count command					
X1B	Y1B	CH2 Count enable						
X1C	Y1C	CH2 Present value read request						
X1D	Y1D	CH2 External preset detection reset command						
X1E	Y1E	Not used						
X1F	Y1F							

6.3.4 Buffer memory address comparison

Sequence program change is required as the assignment of buffer memory differs.

For details of the buffer memory or sequence program, refer to the High-Speed Counter Module User's Manual.

AD61S1				QD62-H02					
Address (Dec.)		Name	Read/write	Address (Dec.)		Name		Read/write	
CH1	CH2			CH1	CH2				
1	33	Preset value write (Lower and middle)	W	0	32	Preset value setting	(L)	R/W	
(2)	(34)			Preset value write (Upper)	1		33		(H)
3	35	Mode register	R/W	2	34	Present value	(L)	R	
4	36	Present value read (Lower and middle)	R	3	35		(H)		
(5)	(37)	Present value read (Upper)		R/W	4	36	Coincidence output point set No.1	(L)	R/W
6	38	Set value read/write (Lower and middle)	5		37	(H)			
(7)	(39)	Set value read/write (Upper)	R/W	6	38	Coincidence output point set No.2	(L)	R/W	
				7	39		(H)		
Address in parentheses in the above table indicates the upper 8 bits of 24-bit data.				8	40	Overflow detection flag		R	
				9	41	Counter function selection setting		R/W	
				10	42	Sampling/periodic setting			
				11	43	Sampling/periodic counter flag		R	
				12	44	Latch count value	(L)		
				13	45		(H)		
				14	46	Sampling count value	(L)		
				15	47		(H)		
				16	48	Periodic pulse count previous value	(L)		
				17	49		(H)		
				18	50	Periodic pulse count present value	(L)		
				19	51		(H)		
				20	52	Ring counter minimum value	(L)	R/W	
				21	53		(H)		
				22	54	Ring counter maximum value	(L)		
				23	55		(H)		
				24	56	System area (Not used)			-
				to	to				
				31	63				

7 POSITIONING MODULE REPLACEMENT

7.1 List of Positioning Module Alternative Models for Replacement

Production discontinuation		Transition to Q series		
Product	Model	Model	Remarks (Restrictions)	
Positioning module*2	AD70	QD73A1	1) External wiring : Not changed*3 (An external power supply (±15VDC) is not required. The connector installation direction is reverse.) 2) Number of slots : Changed (1 slot → 2 slots) 3) Program : Buffer memory assignment and change of the setting method 4) Performance specifications change: Upward-compatibility 5) Function specifications: Partly changed (LED indication and function setting method)	
	AD70D	None	Mount AD70D to the QA6□B-type extension base unit. Otherwise, replacing with the QD75M system is recommended.	
	AD72	None	Replacing with two QD73A1 modules or QD75 system is recommended.	
	AD75M1	QD75M1	1) External wiring : Connector and manual pulsar wiring are changed. 2) Number of slots : Not changed 3) Program : I/O signals, XY assignment, buffer memory assignment and different functions are changed. 4) Performance specifications change: Upward-compatibility 5) Function specifications: Partly changed	
	AD75M2	QD75M2	1) External wiring : Connector and manual pulsar wiring are changed. 2) Number of slots : Not changed 3) Program : I/O signals, XY assignment, buffer memory assignment and different functions are changed. 4) Performance specifications change: Upward-compatibility 5) Function specifications: Partly changed	
	AD75M3	QD75M4	1) External wiring : Connector and manual pulsar wiring are changed. 2) Number of slots : Not changed 3) Program : I/O signals, XY assignment, buffer memory assignment and different functions are changed. 4) Performance specifications change: Upward-compatibility 5) Function specifications: Partly changed	
	AD75P1-S3	QD75P1N*1 (when an open collector is connected)	QD75D1N*1 (when a differential driver is connected)	1) External wiring : Connector and manual pulsar wiring are changed. 2) Number of slots : Not changed 3) Program : I/O signals, XY assignment, buffer memory assignment and different functions are changed. 4) Performance specifications change: Not changed. 5) Function specifications: Partly changed
		QD75P2N*1 (when an open collector is connected)		
	AD75P2-S3	QD75D2N*1 (when a differential driver is connected)		1) External wiring : Connector and manual pulsar wiring are changed. 2) Number of slots : Not changed 3) Program : I/O signals, XY assignment, buffer memory assignment and different functions are changed. 4) Performance specifications change: Not changed. 5) Function specifications: Partly changed

Production discontinuation		Transition to Q series	
Positioning module*2	AD75P3-S3	QD75P4N*1 (when an open collector is connected)	1) External wiring : Connector and manual pulsar wiring are changed. 2) Number of slots : Not changed
		QD75D4N*1 (when a differential driver is connected)	3) Program : I/O signals, XY assignment, buffer memory assignment and different functions are changed. 4) Performance specifications change: Not changed. 5) Function specifications: Partly changed

- *1 The QD75P□N and QD75D□N are the upward-compatibility for the QD75P□ and QD75D□ and their programs are the same when they are replaced.
Change the sequence program as necessary with checking the processing timing, because performances such as the starting time and data update cycle are improved.
- *2 Production of AD71 (S1/S2/S7) has been discontinued since the end of October 2004.
For details, refer to Technical Bulletin No.T12-0015.
When replacing the existing AD71 (S1/S2/S7) with "QD75P/QD75D", refer to Technical Bulletin "FA-A-0060-A: Procedures for Replacing Positioning Module AD71 with QD75".
- *3 When the AD70 being used in the setting that the negative voltage is output when the positioning address increases is replaced with the QD73A1, the wiring change between the AD70 and an encoder is required. For details, refer to Section 7.6.6.

7.2 AD70D

No Q series alternative model is available. Consider mounting the existing module on the QA6□B extension base unit or shifting to the QD75M system.

7.3 AD72

No Q series alternative model is available.
Consider mounting the existing module on the QA6□B extension base unit, replacing with two QD73A1 modules, or shifting to the QD75 system.
Note that with two QD73A1 modules after the replacement, the interpolation function cannot be performed.

7.4 AD75P1-S3/P2-S3/P3-S3

7.4.1 Performance comparison

○ : Compatible, △ : Partial change required, × : Incompatible

Model		Item						Compat- ibility	Precautions for replacement
		AD75P1-S3	AD75P2-S3	AD75P3-S3	QD75P1N QD75D1N	QD75P2N QD75D2N	QD75P4N QD75D4N		
No. of control axes		1	2	3	1	2	4	○	
No. of positioning data items		600/axis*1			600/axis			○	
Position control interpolation functions	2-axis linear interpolation	×	○	○	×	○	○ (3-/4-axis linear interpolation : available)	○	
	2-axis circular interpolation	×	○	○	×	○	○		
Positioning system	Position control	○			○			○	
	Speed control	○			○				
	Speed-position switching control	○			○				

○: Compatible, △: Partial change required, ×: Incompatible

Item	Model			QD75P1N	QD75P2N	QD75P4N	Compat- ibility	Precautions for replacement
	AD75P1-S3	AD75P2-S3	AD75P3-S3	QD75D1N	QD75D2N	QD75D4N		
Positioning range*2	<Absolute system> -214748364.8 to 214748364.7 (μm) /-13421772.8 to 13421772.7 (μm) -21474.83648 to 21474.83647 (inch) /-1342.17728 to 1342.17727 (inch) 0 to 359.99999 (degree) /0 to 359.99999 (degree) -2147483648 to 2147483647 (pulse) /-134217728 to 134217727 (pulse) <Incremental system> -214748364.8 to 214748364.7 (μm) /-13421772.8 to 13421772.7 (μm) -21474.83648 to 21474.83647 (inch) /-1342.17728 to 1342.17727 (inch) -21474.83648 to 21474.83647 (degree) /-1342.17728 to 1342.17727 (degree) -2147483648 to 2147483647 (pulse) /-134217728 to 134217727 (pulse) <In speed-position switching control (INC mode)/position-speed switching control> 0 to 214748364.7 (μm) /0 to 13421772.7 (μm) 0 to 21474.83647 (inch) /0 to 1342.17727 (inch) 0 to 21474.83647 (degree) /0 to 1342.17727 (degree) 0 to 2147483647 (pulse) /0 to 134217727 (pulse)			<Absolute system> -214748364.8 to 214748364.7 (μm) -21474.83648 to 21474.83647 (inch) 0 to 359.99999 (degree) -2147483648 to 2147483647 (pulse) <Incremental system> -214748364.8 to 214748364.7 (μm) -21474.83648 to 21474.83647 (inch) -21474.83648 to 21474.83647 (degree) -2147483648 to 2147483647 (pulse) <In speed-position switching control (INC mode)/position-speed switching control> 0 to 214748364.7 (μm) 0 to 21474.83647 (inch) 0 to 21474.83647 (degree) 0 to 2147483647 (pulse) <In speed-position switching control (ABS mode)> 0 to 359.99999 (degree)			○	
Speed command range*2	0.01 to 6000000.00 (mm/min) /0.01 to 375000.00 (mm/min) 0.001 to 600000.000 (inch/min) /0.001 to 37500.000 (inch/min) 0.001 to 600000.000 (degree/min) /0.001 to 37500.000 (degree/min) 1 to 1000000 (pulse/s) /1 to 62500 (pulse/s)			0.01 to 20000000.00 (mm/min) 0.001 to 2000000.000 (inch/min) 0.001 to 2000000.000 (degree/min) 1 to 1000000 (pulse/s)			○	
Machine OPR function (OPR method)	○(6 OPR methods)			○(6 OPR methods)			○	
JOG operation	○			○			○	

○ : Compatible, △ : Partial change required, × : Incompatible

Item	Model			QD75P1N	QD75P2N	QD75P4N	Compat- ibility	Precautions for replacement	
	AD75P1-S3	AD75P2-S3	AD75P3-S3	QD75D1N	QD75D2N	QD75D4N			
Manual pulse generator function	1 generator/axis			1 generator/module			△	<ul style="list-style-type: none"> On QD75P□N/ QD75D□N, the manual pulse generator cannot be used by each axis independent. When connecting the manual pulse generator for each axis is required, use one axis module. The manual pulse generator itself can use the same one. The operation for inputting one pulse differs. Set the parameter so that movement amount may be same. 	
Starting time	20ms			1.5 to 2.0ms (when other axes are starting: 1.5 to 2.0ms + 0.1ms to 0.5ms)			○	The starting time becomes fast. Check the processing timing.	
Acceleration /deceleration processing	Automatic trapezoidal acceleration/ deceleration	○			○			○	
	S-pattern acceleration/ deceleration	○			○				
Acceleration /deceleration time	No. of patterns	Acceleration time and deceleration time can be set independently. (4 patterns each)			Acceleration time and deceleration time can be set independently. (4 patterns each)			○	
	Setting range	Changeover between 1 to 65535ms/1 to 8388608ms possible			1 to 8388608ms				
	Sudden stop deceleration	Changeover between 1 to 65535ms/1 to 8388608ms possible			1 to 8388608ms			○	
Compensation	Electronic gears, backlash compensation, near pass ^{*3}			Electronic gears, backlash compensation, near pass ^{*3}			△	Refer to *3.	
Error display	17-segment LED			Error LED			×	For details of diagnostic, use GX Developer.	
History data storage (Start, error, warning)	Provided (4 types, 16 items/module)			Provided (3 types, 16 items/module)			○	The start history during error is integrated into the start history.	
Data storage destination	Flash ROM (battery-less backup)			Flash ROM (battery-less backup)			○		

○: Compatible, △: Partial change required, ×: Incompatible

Item	Model			QD75P1N QD75D1N	QD75P2N QD75D2N	QD75P4N QD75D4N	Compat- ibility	Precautions for replacement
	AD75P1-S3	AD75P2-S3	AD75P3-S3					
Connection connector	10136-3000VE (Soldering type, supplied)			A6CON1 (Soldering type, straight-out type, sold separately)			×	As the connectors differ, wiring change is required. The connectors of QD75P□N/ QD75D□N are sold separately.
	10136-6000EL (Crimping type, sold separately)			A6CON2 (Crimping type, straight-out type, sold separately)				
				A6CON4 (Soldering type, straight-out/diagonal- out type, sold separately)				
Applicable wire size	10136-3000VE: 24 to 30 AWG (approx. 0.05 to 0.2 mm ²)			A6CON1, A6CON4: 0.3mm ²			○	
	10136-6000EL: 28 AWG (approx. 0.08 mm ²)			A6CON2: 24 AWG				
Command pulse output system	Differential driver/Open collector			QD75P□N: Open collector QD75D□N: Differential driver			△	The differential driver and the open collector are separate module. In initial condition, AD75P□-S3 outputs with positive logic, and QD75P□N/ QD75D□N outputs with negative logic.
Max. output pulse	When connected to open collector: 200kpps When connected to differential driver: 400kpps			When connected to open collector: 200kpps When connected to differential driver: 4Mpps			○	
Max. connection distance between servos	When connected to open collector: 2m When connected to differential driver: 10m			When connected to open collector: 2m When connected to differential driver: 10m			○	
Internal current consumption (A) (5VDC)	0.7A or less			QD75P1N: 0.29A	QD75P2N: 0.30A	QD75P4N: 0.36A	○	
				QD75D1N: 0.43A	QD75D2N: 0.45A	QD75D4N: 0.66A		
Flash ROM write count	Max. 100,000 times			Max. 100,000 times			○	When QD75P□N/ QD75D□N carries out the flash write 26 times from the sequence program, an error occurs. The error reset enables to perform the flash write.
Occupied I/O points	32 points (I/O assignment: special 32 points)			32 points (I/O assignment: intelligent 32 points)			○	
No. of module occupied slots	1			1			○	
Weight	0.35kg			QD75P1N: 0.14kg	QD75P2N: 0.14kg	QD75P4N: 0.16kg	○	
				QD75D1N: 0.15kg	QD75D2N: 0.15kg	QD75D4N: 0.16kg		

○ : Compatible, △ : Partial change required, × : Incompatible

Item	Model	AD75P1-S3	AD75P2-S3	AD75P3-S3	QD75P1N QD75D1N	QD75P2N QD75D2N	QD75P4N QD75D4N	Compat- ibility	Precautions for replacement
I/O signal for external devices	STRT signal	○(External start signal)			× (integrated into CHG)			△	When using both the speed-position switching control and the external start, input the external start signal to the interrupt module, and start using the direct output.
	CHG signal	Speed-position switching signal			External command signal (External start or speed-position switching selectable with parameters)			○	
	in-Position (INP)	○(for monitor)			×			△	No INP signal. When it is required for monitor, monitor using the input module.
	Signal logic switching	Command pulse output signal only			○			○	The default logic of pulse output differs.
Peripheral devices (data setting, etc.)	Connection with peripheral devices	Direct connection			Connection via programmable controller CPU, Q corresponding serial communication module, Q corresponding MELSECNET/H remote I/O module			○	The connecting shape differs.
	AD75TU	○			×			×	AD75TU cannot be used. Use GX Configurator-QP.
	GX Configurator	GX Configurator-AP			GX Configurator-QP			△	Available GX Configurator differs.

- *1 With AD75P□-S3, Nos.1 to 100 data items/axis of positioning data can be set using the buffer memory and Nos.1 to 600 data/axis can be set with QD75P□N/QD75D□N.
The positioning data in the buffer memory is not backed up.
- *2 Indicates the standard mode/stepping motor mode about AD75P□-S3.
- *3 The near pass function is valid only during the continuous path control. (AD75P□-S3: Selected with parameters, QD75P□N/QD75D□N: Standard function)
QD75P□N/QD75D□N does not have address pass mode. When being asked for passing the positioning address, continue with continuous running. (However, it will stop once.)

7.4.2 Function comparison

(1) Deleted function from AD75P1-S3/P2-S3/P3-S3

When using the following function on AD75P□-S3, change the program.

Deleted functions	Precautions for replacement
Stepping motor mode	The setting is not required when using stepping motor due to its performance gain.
Fast machine OPR	With the QD75P□N/QD75D□N, there is no possible function for replacement.
Special start (stop)	Execute it separately for the start two times.
Indirect designation	In the QD75P□N/QD75D□N, the start block area on the buffer memory is expanded to five blocks (0 to 4). Each start block can be directly designated with positioning start No. (7000 to 7004).
Block transfer	With the AD75P□-S3, this interface is used to set positioning data Nos. 101 to 600 that do not exist on the buffer memory.
Positioning data I/F	Since all positioning data can be set in the buffer memory with the QD75P□N/QD75D□N, this function is deleted.
Start history during errors	The contents are the same as the start history. Therefore, the QD75P□N/QD75D□N stores only the start history.
System monitor data (Module name, OS type, OS version)	These data were deleted because they can be displayed in system monitor "Module's detailed information" of GX Developer. (Refer to GX Developer Operating Manual.)

(2) Changed function from AD75P1-S3/P2-S3/P3-S3

In case of using the following functions with AD75P□-S3, make sure that there is no operation problems when converted to QD75P□N/QD75D□N.

Changed functions	Change description		
Software stroke limit function	<ol style="list-style-type: none"> The limit check of arc address is carried out only when a sub point is designated. It is not carried out when a center point is designated. The software stroke limit check during speed control is carried out in the following cases: <ul style="list-style-type: none"> When the software stroke limit is applied to the current feed value with Pr.14 and the current feed value is updated with Pr.21 When the software stroke limit is applied to the machine feed value If an attempt is made to change the current value but the designated address is out of the software stroke limit range, the attempt is considered as an error and the current value is not changed. Error code change AD75P□-S3: There are 3 types of errors for each upper and lower stroke limit. (error code 509 to 512) QD75P□N/QD75D□N: Errors for the software stroke upper limit are integrated in to error code 507. Errors for the lower limit are integrated in to error code 508. Error codes 509 to 512 are deleted. 		
Current value changing M code function	<ol style="list-style-type: none"> An error occurs when the designated new current value is out of the software stroke limit range. The M code setting value is valid during the positioning data current value changing instruction. 		
Acceleration/deceleration speed control	<ol style="list-style-type: none"> An error occurs when the command frequency value calculated from the speed limit value exceeds the maximum command frequency of the positioning module being used. Only two-word type (1 to 8388608ms) can be used as the setting value for the acceleration/deceleration time. 		
Stop process and restart after stop positioning operation stop	<ol style="list-style-type: none"> "Peripheral side (emergency) stop" is deleted from the stop causes of Stop group 2 "sudden stop selection". "Test mode fault" in the stop causes of Stop group 3 "sudden stop selection" is changed to be in the stop causes of Stop group 2 "sudden stop selection". "Stop (QD75 peripheral)" is added to the stop causes of Stop group 3 "sudden stop selection". Error code 100 (Peripheral device stop during operation) is deleted. "Programmable controller CPU error occurrence" is added to the stop causes of Stop group 2 Sudden stop selection. 		
READY signal (X0)	AD75P□-S3	QD75P□N/QD75D□N	
	OFF	Normal (READY)	Not READY/WDT error
	ON	Not READY/WDT error	Normal (READY)
Manual pulse generator operation	The No. of connectable manual pulse generator is changed from 1generator/1axis to 1generator/1 module.		
Axis operation status	"Step stopped" is changed to "Stopped" and "Step error occurring" is changed to "Error occurring".		
Continuous path control	<ul style="list-style-type: none"> AD75P□-S3: If the reference axis operates in reverse direction, the control is internally changed into the continuous positioning control. (restart after deceleration stop) QD75P□N/QD75D□N: Even if the reference axis operates in reverse direction with interpolation, the control remains as the continuous path control. (In single-axis operation, the operation is the same as that of the AD75P□-S3.) 		
Near pass	For the continuous path control, only the near pass function is available. Positioning address pass is not conducted.		
2-axis interpolation • 2-axis linear interpolation • 2-axis fixed-feed • Circular interpolation	The interpolation target axis can be randomly set with a positioning identifier.		

Changed functions	Change description		
Step function	1. "Step stopped" is changed to "Stopped" and "Step error occurring" is changed to "Error occurring" in the axis operations status parameters. 2. The restart command for step start information (02H) is deleted. 3. The step operation is restarted with the restart command.		
Command in-position function	The command in-position width is expanded. • AD75P□-S3: 1 to 32767000 • QD75P□N/QD75D□N: 1 to 2147483647		
Positioning start No.	7004 to 7010 (block start designation) and 8000 to 8049 (indirect designation) are deleted.		
block start data	With QD75P□N/QD75D□N, number of blocks has been change to 5 (7000 to 7004). (With the AD75P□-S3, this data is called "Positioning start information".)		
Start history	The configuration of "start information" and "start No." is changed so that the start No. can be directly checked.		
Basic parameter1 "Pr.5 Pulse output mode"	When the programmable controller is turned ON or the programmable controller CPU module is reset, the valid value is only the first value after the programmable controller READY signal (Y0) turns from OFF to ON.		
Detailed parameters "Pr.15 Software stroke limit valid/invalid setting"		AD75P□-S3	QD75P□N/QD75D□N
	0 (Factory setting)	Software stroke limits invalid for manual operation	Software stroke limits valid for manual operation
	1	Software stroke limits valid for manual operation	Software stroke limits invalid for manual operation

7.4.3 I/O signal comparison to programmable controller CPU

Sequence program change is required as the I/O signals differ.

For details of the I/O signals or sequence program, refer to the Type QD75P/QD75D Positioning Module User's Manual.

Input (X)			Output (Y)		
Signal name	AD75P□-S3	QD75P□N/ QD75D□N	Signal name	AD75P□-S3	QD75P□N/ QD75D□N
(QD75/AD75) READY	X00*	X00*	Axis 1 Positioning start	Y10	Y10
Axis 1 Start complete	X01	X10	Axis 2 Positioning start	Y11	Y11
Axis 2 Start complete	X02	X11	Axis 3 Positioning start	Y12	Y12
Axis 3 Start complete	X03	X12	Axis 4 Positioning start	-	Y13
Axis 4 Start complete	-	X13	Axis 1 Stop	Y13	Y04
Axis 1 BUSY	X04	X0C	Axis 2 Stop	Y14	Y05
Axis 2 BUSY	X05	X0D	Axis 3 Stop	Y1C	Y06
Axis 3 BUSY	X06	X0E	Axis 4 Stop	-	Y07
Axis 4 BUSY	-	X0F	Axis 1 Forward run JOG start	Y16	Y08
Axis 1 Positioning complete	X07	X14	Axis 1 Reverse run JOG start	Y17	Y09
Axis 2 Positioning complete	X08	X15	Axis 2 Forward run JOG start	Y18	Y0A
Axis 3 Positioning complete	X09	X16	Axis 2 Reverse run JOG start	Y19	Y0B
Axis 4 Positioning complete	-	X17	Axis 3 Forward run JOG start	Y1A	Y0C
Axis 1 Error detection	X0A	X08	Axis 3 Reverse run JOG start	Y1B	Y0D
Axis 2 Error detection	X0B	X09	Axis 4 Forward run JOG start	-	Y0E
Axis 3 Error detection	X0C	X0A	Axis 4 Reverse run JOG start	-	Y0F
Axis 4 Error detection	-	X0B	Programmable controller READY	Y1D	Y00
Axis 1 M code ON	X0D	X04	Axis 1 Execution prohibition flag	-	Y14
Axis 2 M code ON	X0E	X05	Axis 2 Execution prohibition flag	-	Y15
Axis 3 M code ON	X0F	X06	Axis 3 Execution prohibition flag	-	Y16
Axis 4 M code ON	-	X07	Axis 4 Execution prohibition flag	-	Y17
Synchronization flag	-	X01	Not used	Y00 to Y0F Y1E to Y1F	Y01 to Y03 Y18 to Y1F
Not used	X10 to X1F	X02, X03 X18 to X1F			

* The ON/OFF statuses for READY are different between the QD75P□N/QD75D□N and AD75P□-S3.

	Not READY/WDT error	READY
QD75P□N/ QD75D□N	OFF	ON
AD75P□-S3	ON	OFF

7.4.4 Buffer memory address comparison

For details of the buffer memory or sequence program, refer to the Type QD75P/QD75D Positioning Module User's Manual.

□ area shows the differences between AD75P□-S3 and QD75P□N/QD75D□N.

Item of AD75P□-S3	Buffer memory address					
	AD75P□-S3			QD75P□N/QD75D□N		
	Axis 1	Axis 2	Axis 3	Axis 1	Axis 2	Axis 3
Pr.1 Unit setting	0	150	300	0	150	300
Pr.2 1 No. of pulses per rotation (Ap)	1	151	301	1	151	301
Pr.3 1 Movement amount per rotation (Al)	2	152	302	2	152	302
Pr.4 Unit magnification (Am)	3	153	303	3	153	303
Pr.5 Pulse output mode	4	154	304	4	154	304
Pr.6 Rotation direction setting	5	155	305	5	155	305
Pr.7 Speed limit value	6	156	306	10	160	310
	7	157	307	11	161	311
Pr.8 Acceleration time 0	8	158	308	12	162	312
	9	159	309	13	163	313
Pr.9 Deceleration time 0	10	160	310	14	164	314
	11	161	311	15	165	315
Pr.10 Bias speed at start	12	162	312	6	156	306
	13	163	313	7	157	307
Pr.11 Stepping motor mode selection amount	14	164	314	-	-	-
Pr.12 Backlash compensation amount	15	165	315	17	167	317
Pr.13 Software stroke limit upper limit value	16	166	316	18	168	318
Pr.14 Software stroke limit lower limit value	17	167	317	19	169	319
Pr.15 Software stroke limit selection	18	168	318	20	170	320
	19	169	319	21	171	321
Pr.16 Software stroke limit valid/invalid setting	20	170	320	22	172	322
Pr.17 Command in-position width	21	171	321	23	173	323
	22	172	322	24	174	324
Pr.18 Torque limit setting value	23	173	323	25	175	325
Pr.19 M code ON signal output timing	24	174	324	26	176	326
	25	175	325	27	177	327
Pr.20 Speed switching mode	26	176	326	28	178	328
Pr.21 Interpolation speed designation method	27	177	327	29	179	329
Pr.22 Current feed value during speed control	28	178	328	30	180	330
Pr.23 Manual pulse generator selection	29	179	329	-	-	-
Pr.24 Logic selection for pulse output to the drive unit	30	180	330	-	-	-
Pr.25 Size selection for acceleration/deceleration time	31	181	331	-	-	-
	36	186	336	36	186	336
Pr.26 Acceleration time 1	37	187	337	37	187	337
	38	188	338	38	188	338
Pr.27 Acceleration time 2	39	189	339	39	189	339
	40	190	340	40	190	340
Pr.28 Acceleration time 3	41	191	341	41	191	341
	42	192	342	42	192	342
Pr.29 Deceleration time 1	43	193	343	43	193	343

Item of AD75P□-S3	Buffer memory address					
	AD75P□-S3			QD75P□N/QD75D□N		
	Axis 1	Axis 2	Axis 3	Axis 1	Axis 2	Axis 3
[Pr.30] Deceleration time 2	44	194	344	44	194	344
	45	195	345	45	195	345
[Pr.31] Deceleration time 3	46	196	346	46	196	346
	47	197	347	47	197	347
[Pr.32] JOG Speed limit value	48	198	348	48	198	348
	49	199	349	49	199	349
[Pr.33] JOG operation acceleration time selection	50	200	350	50	200	350
[Pr.34] JOG operation deceleration time selection	51	201	351	51	201	351
[Pr.35] Acceleration/deceleration process selection	52	202	352	52	202	352
[Pr.36] S-pattern proportion	53	203	353	53	203	353
[Pr.37] Sudden stop deceleration time	54	204	354	54	204	354
	55	205	355	55	205	355
[Pr.38] Stop group 1 sudden stop selection	56	206	356	56	206	356
[Pr.38] Stop group 2 sudden stop selection	57	207	357	57	207	357
[Pr.40] Stop group 3 sudden stop selection	58	208	358	58	208	358
[Pr.41] Positioning complete signal output time	59	209	359	59	209	359
[Pr.42] Allowable circular interpolation error width	60	210	360	60	210	360
	61	211	361	61	211	361
[Pr.43] External start function selection	62	212	362	62	212	362
(QD75P□N/QD75D□N: [Pr.42] External command function selection)						
[Pr.44] Near pass mode selection for path control	66	216	366	-	-	-
[Pr.45] OPR method	70	220	370	70	220	370
[Pr.46] OPR direction	71	221	371	71	221	371
[Pr.37] OP address	72	222	372	72	222	372
	73	223	373	73	223	373
[Pr.48] OPR speed	74	224	374	74	224	374
	75	225	375	75	225	375
[Pr.49] Creep speed	76	226	376	76	226	376
	77	227	377	77	227	377
[Pr.50] OPR retry	78	228	378	78	228	378
[Pr.51] OPR dwell time	79	229	379	79	229	379
[Pr.52] Setting for the movement amount after near-point dog ON	80	230	380	80	230	380
	81	231	381	81	231	381
[Pr.53] OPR acceleration time selection	82	232	382	82	232	382
[Pr.54] OPR deceleration time selection	83	233	383	83	233	383
[Pr.55] OP shift amount	84	234	384	84	234	384
	85	235	385	85	235	385
[Pr.56] OPR torque limit value	86	236	386	86	236	386
[Pr.57] Speed designation during OP shift	88	238	388	88	238	388
[Pr.58] Dwell time during OPR retry	89	239	389	89	239	389

Item of AD75P□-S3	Buffer memory address	
	AD75P□-S3	QD75P□N/QD75D□N
	Common for axis 1, 2, 3	Common for axis 1, 2, 3, 4
Md.1 In test mode flag	450	1200
Md.2 Module name	451	-
Md.3 OS type	452 453 454 455	-
Md.4 OS version	456 457	-
Md.5 Clock data (hour: minute)	460	-
Md.6 Clock data (second: 100 ms)	461	-
(Pointer number)	(0) to (15)	
Md.7 Start axis (QD75P□N/QD75D□N: Md.3 Start information)	462 to 537	1212 to 1287
Md.8 Operation type (QD75P□N/QD75D□N: Md.4 Start No.)	463 to 538	1213 to 1288
Md.9 Start Hour: minute (QD75P□N/QD75D□N: Md.5 Start Hour)	464 to 539	1214 to 1289
Md.10 Start Second: 100 ms (QD75P□N/QD75D□N: Md.6 Start Minute: second)	465 to 540	1215 to 1290
Md.11 Error judgment	466 to 541	1216 to 1291
Md.12 Start history pointer	542	1292
(Pointer number)	(0) to (15)	
Md.13 Start axis	543 to 618	-
Md.14 Operation type	544 to 619	-
Md.15 Start Hour: minute	545 to 620	-
Md.16 Start Second: 100 ms	546 to 621	-
Md.17 Error judgment	547 to 622	-
Md.18 Start history storage during error	623	-
(Pointer number)	(0) to (15)	
Md.19 Axis in which the error occurred	624 to 684	1293 to 1353
Md.20 Axis error No.	625 to 685	1294 to 1354
Md.21 Axis error occurrence Hour: minute (QD75P□N/QD75D□N: Md.11 Axis error occurrence (Hour))	626 to 686	1295 to 1355
Md.22 Axis error occurrence Second: 100 ms (QD75P□N/QD75D□N: Md.12 Axis error occurrence (Minutes: second))	627 to 687	1296 to 1356
Md.23 Error history pointer	688	1357

Item of AD75P□-S3	Buffer memory address	
	AD75P□-S3	QD75P□N/QD75D□N
	Common for axis 1, 2, 3	Common for axis 1, 2, 3, 4
(Pointer number)	(0) to (15)	
[Md.24] Axis in which the warning occurred	689 to 749	1358 to 1418
[Md.25] Axis warning No.	690 to 750	1359 to 1419
[Md.26] Axis warning occurrence Hour: minutes (QD75P□N/QD75D□N: [Md.16] Axis warning occurrence (Hour))	691 to 751	1360 to 1420
[Md.27] Axis warning occurrence Second: 100 ms (QD75P□N/QD75D□N: [Md.17] Axis warning occurrence (Minutes: second))	3692 to 752	1361 to 1421
[Md.28] Warning history pointer	753	1422

Item of AD75P□-S3	Buffer memory address					
	AD75P□-S3			QD75P□N/QD75D□N		
	Axis 1	Axis 2	Axis 3	Axis 1	Axis 2	Axis 3
Md.29 Current feed value	800	900	1000	800	900	1000
	801	901	1001	801	901	1001
Md.30 Machine feed value	802	902	1002	802	902	1002
	803	903	1003	803	903	1003
Md.31 Feedrate	804	904	1004	804	904	1004
	805	905	1005	805	905	1005
Md.32 Valid M code	806	906	1006	808	908	1008
Md.33 Axis error No.	807	907	1007	806	906	1006
Md.34 Axis warning No.	808	908	1008	807	907	1007
Md.35 Axis operation status	809	909	1009	809	909	1009
Md.36 Current speed	810	910	1010	810	910	1010
	811	911	1010	811	911	1011
Md.37 Axis feedrate	812	912	1012	812	912	1012
	813	913	1013	813	913	1013
Md.38 Speed-position switching control positioning amount	814	914	1014	814	914	1014
	815	915	1015	815	915	1015
Md.39 External input/output signal	816	916	1016	816	916	1016
Md.40 Status	817	917	1017	817	917	1017
Md.41 Target value	818	918	1018	818	918	1018
	819	919	1019	819	919	1019
Md.42 Target speed	820	920	1020	820	920	1020
	821	921	1021	821	921	1021
Md.43 OP absolute position	822	922	1022	-	-	-
	823	923	1023	-	-	-
Md.44 Movement amount after near-point dog ON	824	924	1024	824	924	1024
	825	925	1025	825	925	1025
Md.45 Torque limit stored value	826	926	1026	826	926	1026
Md.46 Special start data instruction code setting value	827	927	1027	827	927	1027
Md.47 Special start data instruction parameter setting value	828	928	1028	828	928	1028
Md.48 Start positioning data No. setting value	829	929	1029	829	929	1029
Md.49 In speed control flag	830	930	1030	830	930	1030
Md.50 In speed change processing flag	831	931	1031	831	931	1031
Md.51 Start data pointer being executed	832	932	1032	834	934	1034
Md.52 Last executed positioning data No.	833	933	1033	837	937	1037
Md.53 Repetition counter	834	934	1034	832	932	1032
(QD75P□N/QD75D□N: Md.41 Special start repetition counter)						
Md.54 Positioning data No. being executed	835	935	1035	835	935	1035
Md.55 Block No. being executed	836	936	1036	836	936	1036
Md.56 Positioning data being executed	838 to 847	938 to 947	1038 to 1047	838 to 847	938 to 947	1038 to 1047
Deceleration starting flag	-	-	-	899	999	1099

Item of AD75P□-S3	Buffer memory address					
	AD75P□-S3			QD75P□N/QD75D□N		
	Axis 1	Axis 2	Axis 3	Axis 1	Axis 2	Axis 3
Cd.1 Clock data setting (hour)	1100			-		
Cd.2 Clock data setting (minute, second)	1101			-		
Cd.3 Clock data writing	1102			-		
Cd.4 Target axis	1103			-		
Cd.5 Positioning data No.	1104			-		
Cd.6 Write pattern	1105			-		
Cd.7 Read/write request	1106			-		
Cd.8 Read/write positioning data I/F	1108 to 1137			-		
Cd.9 Flash ROM write request	1138			1900		
Cd.10 Parameter initialization request	1139			1901		
Cd.11 Positioning start No.	1150	1200	1250	1500	1600	1700
Cd.12 Axis error reset	1151	1201	1251	1502	1602	1702
Cd.13 Restart command	1152	1202	1252	1503	1603	1703
Cd.14 M code OFF request	1153	1203	1253	1504	1604	1704
Cd.15 New current value	1154	1204	1254	1506	1606	1706
	1155	1205	1255	1507	1607	1707
Cd.16 New speed value	1156	1206	1256	1514	1614	1714
	1157	1207	1257	1515	1615	1715
Cd.17 Speed change request	1158	1208	1258	1516	1616	1716
Cd.18 Positioning operation speed override	1159	1209	1259	1513	1613	1713
Cd.19 JOG speed	1160	1210	1260	1518	1618	1718
	1161	1211	1261	1519	1619	1719
Cd.20 Speed-position switching enable flag	1163	1213	1263	1528	1628	1728
Cd.21 Speed-position switching control movement amount change register	1164	1214	1264	1526	1626	1726
	1165	1215	1265	1527	1627	1727
Cd.22 Manual pulse generator enable flag	1167	1217	1267	1524	1624	1724
Cd.23 Manual pulse generator 1 pulse input magnification	1168	1218	1268	1522	1622	1722
	1169	1219	1269	1523	1623	1723
Cd.24 OPR return request flag OFF request	1170	1220	1270	1521	1621	1721
Cd.25 External start valid	1171	1221	1271	1505	1605	1705
(QD75P□N/QD75D□N: Cd.8 External command valid)						
Cd.26 Step valid flag	1172	1222	1272	1545	1645	1745
Cd.27 Step mode	1173	1223	1273	1544	1644	1744
Cd.28 Step start information	1174	1224	1274	1546	1646	1746
Cd.29 Skip command	1175	1225	1275	1547	1647	1747
Cd.30 New torque value	1176	1226	1276	1525	1625	1725
Cd.31 Positioning starting point No.	1178	1228	1278	1501	1601	1701
Cd.32 Interrupt request during continuous operation	1181	1231	1281	1520	1620	1720
Cd.33 New acceleration time value	1184	1234	1284	1508	1608	1708
	1185	1235	1285	1509	1609	1709
Cd.34 New deceleration time value	1186	1236	1286	1510	1610	1710
	1187	1237	1287	1511	1611	1711
Cd.35 Acceleration/deceleration time change during speed change, enable /disable selection	1188	1238	1288	1512	1612	1712

Item of AD75P□-S3		Buffer memory address												
		AD75P□-S3						QD75P□□/QD75D□□						
		Axis 1		Axis 2		Axis 3		Axis 1		Axis 2		Axis 3		
Positioning data*1	Da.1 Operation pattern	No.1	1300		2300		3300		2000		8000		14000	
	Da.2 Control system													
	Da.3 Acceleration time No.													
	Da.4 Deceleration time No.													
	Da.5 M code/condition data No.		1301		2301		3301		2001		8001		14001	
	Da.8 Dwell time/JUMP destination positioning data No.		1302		2302		3302		2002		8002		14002	
	Empty		1303		2303		3303		2003		8003		14003	
	Da.7 Command speed		1304		2304		3306		2004		8004		14004	
	Da.5 Positioning address/movement amount		1305		2305		3307		2005		8005		14005	
			1306		2306		3306		2006		8006		14006	
Da.6 Arc address	1307		2307		3307		2007		8007		14007			
	1308		2308		3308		2008		8008		14008			
No.2	1309		2309		3309		2009		8009		14009			
No.2	1310 to 1319		2310 to 2319		3310 to 3319		2010 to 2019		8010 to 8019		14010 to 14019			
No.3	1320 to 1329		2320 to 2329		3320 to 3329		2020 to 2029		8020 to 8029		14020 to 14029			
to	to		to		to		to		to		to			
No.100	2290 to 2299		3290 to 3299		4290 to 4299		2990 to 2999		8990 to 8999		14990 to 14999			
Start block data*2	Da.10 Shape	1st point	4300 4350		4550 4600		4800 4850		26000 26050		27000 27050		28000 28050	
	Da.11 Start data No.													
	Da.12 Special start instruction													
	Da.13 Parameter													
	2nd point													
3rd point	4302 4352		4552 4602		4802 4852		26002 26052		27002 27052		28002 28052			
to	to		to		to		to		to		to			
50th point	4349 4399		4599 4649		4849 4899		26049 26099		27049 27099		28049 28099			
Positioning start information*3	Da.14 Condition target	No.1	4400		4650		4900		26100		27100		28100	
	Da.15 Condition operator													
	Da.16 Address		4402		4652		4902		26102		27102		28102	
			4403		4653		4903		26103		27103		28103	
	Da.17 Parameter 1		4404		4654		4904		26104		27104		28104	
			4405		4655		4905		26105		27105		28105	
	Da.18 Parameter 2		4406		4656		4906		26106		27106		28106	
			4407		4657		4907		26107		27107		28107	
	No.2		4410 to 4419		4660 to 4669		4910 to 4919		26110 to 26119		27110 to 27119		28110 to 28119	
	No.3		4420 to 4429		4670 to 4679		4920 to 4929		26120 to 26129		27120 to 27129		28120 to 28129	
to	to		to		to		to		to		to			
No.10	4490 to 4499		4740 to 4749		4990 to 4999		26190 to 26199		27190 to 27199		28190 to 28199			

*1 With the QD75P□□/QD75D□□, the positioning data buffer memory addresses are Nos. 1 to 600.

*2 With the QD75P□□/QD75D□□, it is called [block start data].

*3 With the QD75P□□/QD75D□□, the [block start data] and [condition data] in the area are called [start block 0]. There are five start blocks: 0 to 4

Item of AD75P□-S3		Buffer memory address						
		AD75P□-S3			QD75P□N/QD75D□N			
		Axis 1	Axis 2	Axis 3	Axis 1	Axis 2	Axis 3	
Positioning start information	Indirect designation	Start No.8001	4500	4750	5000	-	-	-
		Start No.8002	4501	4751	5001	-	-	-
		to	to	to	to	to	to	to
		Start No.8050	4549	4799	5049	-	-	-
Programmable controller CPU memory area	Condition judgment target data of the condition data		5050			30000		
			to			to		
			5099			30099		
Target axis		5100			-			
Head positioning block No.		5101			-			
No. of read/write data items		5102			-			
Read/write request		5103			-			
Read/write block		5110 to 6109			-			

7.4.5 Interface specifications comparison with external devices

For the external interface specifications, the following shows the differences between AD75P□-S3 and QD75P□N/QD75D□N.

○ : Compatible, △ : Partial change required

	Item ^{*1}	Differences as Interface specifications ^{*2}	Compat- ibility	Precautions for replacement
Input	Drive unit READY	-	○	
	Upper/lower limit signal	-	○	
	Stop signal	-	○	
	Near-point dog signal	Input resistance: 4.7kΩ→4.3kΩ Response time: 4ms → 1ms	△	<When the machine OPR for the near-point watchdog signal method is used> The input response time for the QD75P□N/QD75D□N is shorter than the A1SD75P□-S3. If a sensor, which the chattering time when the near-point watchdog signal is turned on is long, is used, an error may occur due to the false detection of the ON/OFF status. ^{*4} Check specifications for the sensor.
	Speed-position switching signal	Input resistance: 4.7kΩ→7.7kΩ Response time: 4ms → 1ms	△	
	Zero signal	Input resistance: 3.5kΩ→4.7kΩ (at input of 24V) 0.5kΩ→0.62kΩ (at input of 5V) Response time: 0.8ms→1ms ^{*3} ON voltage : 2.5V→2.0V (at input of 5V)	△	Including the response time differences, reconfirming is required.
Output	Manual pulse generator	ON current: 3.5mA→2mA	○	
	Pulse	-	○	
	Deviation counter clear	-	○	

*1 For the external start and in-position signal of which QD75P□N/QD75D□N does not have, they are not described.

*2 The column of interface specifications differences is described as the form, [Specifications of AD75P□-S3] → [Specifications of QD75P□N/QD75D□N].

*3 The response time difference (0.2 ms) of AD75P□-S3 and QD75P□N/QD75D□N is the time difference of 1pls part for creep speed of 5000pps.

When the accuracy is required, it is required for the creep speed to be low enough value.

*4 If the chattering time is long when the near-point watchdog signal is turned on, the OFF status may be detected shortly after the ON status of the signal is detected (under changing into the creep speed). In this case, the QD75P□N/QD75D□N outputs an error and stops the OPR control.

7.5 AD75M1/M2/M3

7.5.1 Performance comparison

○ : Compatible, △ : Partial change required, × : Incompatible

Model		AD75M1	AD75M2	AD75M3	QD75M1	QD75M2	QD75M4	Compati- bility	Precautions for replacement
No. of control axes		1	2	3	1	2	4	○	
No. of positioning data items		600/axis ^{*1}			600/axis			○	
Position control interpolation functions	2-axis linear interpolation	×	○	○	×	○	○	○	
	2-axis circular interpolation	×	○	○	×	○	○		
Positioning system	Position control	○			○			○	
	Speed control	○			○				
	Speed-position switching control	○			○				
	Position-speed switching control	×			○				
Positioning range		<In Absolute system> -214748364.8 to 214748364.7 (μm) -21474.83648 to 21474.83647 (inch) 0 to 359.99999 (degree) -2147483648 to 2147483647 (PLS) <Incremental system> -214748364.8 to 214748364.7 (μm) -21474.83648 to 21474.83647 (inch) -21474.83648 to 21474.83647 (degree) -2147483648 to 2147483647 (PLS) <In speed-position switching control> 0 to 214748364.7 (μm) 0 to 21474.83647 (inch) 0 to 21474.83647 (degree) 0 to 2147483647 (PLS)			<In Absolute system> -214748364.8 to 214748364.7 (μm) -21474.83648 to 21474.83647 (inch) 0 to 359.99999 (degree) -2147483648 to 2147483647 (PLS) <Incremental system> -214748364.8 to 214748364.7 (μm) -21474.83648 to 21474.83647 (inch) -21474.83648 to 21474.83647 (degree) -2147483648 to 2147483647 (PLS) <In speed-position switching control> 0 to 214748364.7 (μm) 0 to 21474.83647 (inch) 0 to 21474.83647 (degree) 0 to 2147483647 (PLS)			○	
Speed command range		0.01 to 6000000.00 (mm/min) 0.001 to 600000.000 (inch/min) 0.001 to 600000.000 (degree/min) 1 to 1000000 (PLS/s)			0.01 to 20000000.00 (mm/min) 0.001 to 2000000.000 (inch/min) 0.001 to 2000000.000 (degree/min) 1 to 10000000 (PLS/s)			○	
Machine OPR function (OPR method)		○(6 OPR methods)			○(4 OPR methods)			△	Corresponding to the OP unpassed error is required. Return the motor more than one rotation once at the error and perform the OPR start again.
JOG operation		○			○			○	

○: Compatible, △: Partial change required, ×: Incompatible

Model		AD75M1	AD75M2	AD75M3	QD75M1	QD75M2	QD75M4	Compati- bility	Precautions for replacement
Manual pulse generator function		1 generator/axis			1 generator/module			△	<ul style="list-style-type: none"> On QD75M□, the manual pulse generator cannot be used by each axis independent. When connecting the manual pulse generator for each axis is required, use one axis module. The manual pulse generator itself can use the same one. The operation for inputting one pulse differs. Set the parameter so that movement amount may be same.
	Acceleration/ deceleration processing	Automatic trapezoidal acceleration/ deceleration	○			○			○
		S-pattern acceleration/ deceleration	○			○			
Acceleration/ deceleration action time	No. of patterns	Acceleration time and deceleration time can be set independently. (4 patterns each)			Acceleration time and deceleration time can be set independently. (4 patterns each)			○	
	setting range	1 to 65535ms/1 to 8388608ms switching is enabled			1 to 8388608ms				
Compensation		Electronic gears, backlash compensation, near pass ²			Electronic gears, backlash compensation, near pass ²			△	Refer to *2.
Error display		17-segment LED			Error LED			×	For details of diagnostic, use GX Developer.
History data storage (Start, error, warning)		Provided (4 types, 16 items/module)			Provided (3 types, 16 items/module)			○	The start history during error is integrated into the start history.
Data storage destination		Flash ROM (battery-less backup)			Flash ROM (battery-less backup)			○	
Connection connector		10136-3000VE (Soldering type, supplied)			A6CON1, A6CON4 (Soldering type, sold separately)			×	As the connectors differ, wiring change is required. The connectors of QD75M□ is sold separately.
		10136-6000EL (Crimping type, sold separately)			A6CON2 (Crimping type, sold separately)				
		-			A6CON3 (IDC type, sold separately)				
Applicable wire size		10136-3000VE: 24 to 30 AWG (approx. 0.05 to 0.2mm ²)			A6CON1, A6CON4: 0.3mm ²			○	
		10136-6000EL: 28 AWG (approx. 0.08mm ²)			A6CON2: 24 to 28 AWG				
		-			A6CON3: 28 AWG (twisted wire), 30 AWG (single wire)				
SSCNET connection type		Refer to Section 7.5.5 (3).						△	The connector configuration of bass differs.
Maximum extension distance of SSCNET		30m							
Internal current consumption(A) (5VDC)		0.7A or less			QD75M1 : 0.40A	QD75M2 : 0.40A	QD75M4 : 0.40A	○	
Flash ROM write count		Max. 100,000 times			Max. 100,000 times			○	When QD75M□ carries out the flash write 26 times from the sequence program, an error occurs. The error reset enables to perform the flash write.

○ : Compatible, △ : Partial change required, × : Incompatible

Model		AD75M1	AD75M2	AD75M3	QD75M1	QD75M2	QD75M4	Compati- bility	Precautions for replacement
I/O points		32 points (I/O assignment: special 32 points)			32 points (I/O assignment: intelligent 32 points)			○	
No. of module occupied slots		1			1			○	
Weight		0.35kg			0.15kg	0.15kg	0.16kg	○	
I/O signal for external devices	START signal	○			× (integrated into CHG)			△	When using both the speed-position switching control and the external start, input the external start signal to the interrupt module and start using the direct output.
	CHG signal	Speed-position switching signal			External command signal (External start or speed-position switching selectable with parameters)			○	
peripheral devices (data setting, etc.)	Connection with peripheral devices	Direct connection			Connection via programmable controller CPU, Q corresponding serial communication module, Q corresponding MELSECNET/H remote I/O module			○	The connecting shape differs.
	AD75TU	Available			Unavailable			×	AD75TU cannot be used. Use GX Configurator-QP.
	GX Configurator	GX Configurator-AP			GX Configurator-QP ^{*3}			○	Available GX Configurator differs.

*1 Nos.1 to 100 data items/axis of positioning data can be set using the buffer memory and Nos.1 to 600 data/axis can be set with QD75M□.

The positioning data in the buffer memory is not backed up.

*2 The near pass function is valid only during the continuous path control. (AD75M□: Selected with parameters, QD75M□: Standard function)

QD75M□ does not have address pass mode. If passing the positioning address, continue with continuous operation. (However, it will stop once.)

*3 GX Configurator-QP is available with SW2D5C-QD75P or later version.

7.5.2 Function comparison

(1) Deleted function from AD75M1/AD75M2/AD75M3

When using the following function on AD75M□ -S3, change the program.

Deleted functions	Precautions for replacement
Creep speed out of range error (error code: 208)	With QD75M□, there is no the error code of the left column.
Fast machine OPR	With the Q75M□, there is no possible function for replacement.
Special start (stop)	Execute it separately for the start two times.
Indirect designation	In the QD75M□, the start block area on the buffer memory is expanded to five blocks (0 to 4). Each start block can be directly designated with positioning start No. (7000 to 7004).
Block transfer	With the AD75M□, this interface is used to set positioning data Nos. 101 to 600 that do not exist on the buffer memory. Since all positioning data can be set in the buffer memory with the QD75M□, this function is deleted.
Positioning data I/F	
Start history during errors	The contents are the same as the start history. Therefore, the QD75M□ stores only the start history.
System monitor data (Module name, OS type, OS version)	These data were deleted because they can be displayed in system monitor "Module's detailed information" of GX Developer. (Refer to GX Developer Operating Manual.)

(2) Changed function from AD75M1/AD75M2/AD75M3

In case of using the following functions with AD75M□, make sure that there is no operation problems when converted to QD75M□.

Changed functions	Change description									
Software stroke limit function	<ol style="list-style-type: none"> The software stroke limit check of arc address is carried out only when a sub point is designated. It is not carried out when a center point is designated. The software stroke limit check during speed control is carried out in the following cases: <ul style="list-style-type: none"> When the software stroke limit is applied to the current feed value with Pr.14 and the current feed value is updated with Pr.21 When the software stroke limit is applied to the machine feed value If an attempt is made to change the current value but the designated address is out of the software stroke limit range, the attempt is considered as an error and the current value is not changed. Error code change AD75M□: There are 3 types of errors for each upper and lower stroke limit. (error code 509 to 512) QD75M□: Errors for the software stroke upper limit are integrated in to error code 507. Errors for the lower limit are integrated in to error code 508. Error codes 509 to 512 are deleted. 									
Current value changing M code function	<ol style="list-style-type: none"> An error occurs when the designated new current value is out of the software stroke limit range. The M code setting value is valid during the positioning data current value changing instruction. 									
Acceleration/deceleration speed control	Only two-word type (1 to 8388608ms) can be used as the setting value for the acceleration/ deceleration time.									
Stop process and restart after stop positioning operation stop	<ol style="list-style-type: none"> "Peripheral side (emergency) stop" is deleted from the stop causes of Stop group 2 "sudden stop selection". "Test mode fault" in the stop causes of Stop group 3 "sudden stop selection" is changed to be in the stop causes of Stop group 2 "sudden stop selection". "Stop (QD75 peripheral)" is added to the stop causes of Stop group 3 "sudden stop selection". Error code 100 (Peripheral device stop during operation) is deleted. "Programmable controller CPU error occurrence" is added to the stop causes of Stop group 2 "Sudden stop selection". 									
READY signal (X0)	<table border="1"> <thead> <tr> <th></th> <th>AD75M□</th> <th>QD75M□</th> </tr> </thead> <tbody> <tr> <td>OFF</td> <td>Normal (READY)</td> <td>Not READY/WDT error</td> </tr> <tr> <td>ON</td> <td>Not READY/WDT error</td> <td>Normal (READY)</td> </tr> </tbody> </table>		AD75M□	QD75M□	OFF	Normal (READY)	Not READY/WDT error	ON	Not READY/WDT error	Normal (READY)
	AD75M□	QD75M□								
OFF	Normal (READY)	Not READY/WDT error								
ON	Not READY/WDT error	Normal (READY)								
Manual pulse generator operation	The No. of connectable manual pulse generator is changed from 1generator/1axis to 1generator/1 module.									
Axis operation status	"Step stopped" is changed to "Stopped" and "Step error occurring" is changed to "Error occurring".									
Continuous path control	<ul style="list-style-type: none"> AD75M□: If the reference axis operates in reverse direction, the control is internally changed into the continuous positioning control. (restart after deceleration stop) QD75M□: Even if the reference axis operates in reverse direction with interpolation, the control remains as the continuous path control. (In single-axis operation, the operation is the same as that of the AD75M□.) 									
Near pass	For the continuous path control, only the near pass function is available. Positioning address pass is not conducted.									
2-axis interpolation • 2-axis linear interpolation • 2-axis fixed-feed • Circular interpolation	The interpolation target axis can be randomly set with a positioning identifier.									
Step function	<ol style="list-style-type: none"> "Step stopped" is changed to "Stopped" and "Step error occurring" is changed to "Error occurring" in the axis operations status parameters. The restart command for step start information (02H) is deleted. The step operation is restarted with the restart command. 									

Changed functions	Change description		
Command in-position function	The command in-position width is expanded. • AD75M□: 1 to 32767000 • QD75M□: 1 to 2147483647		
Positioning start No.	7004 to 7010 (block start designation) and 8000 to 8049 (indirect designation) are deleted.		
Block start data	With QD75M□, number of blocks has been change to 5 (7000 to 7004). (With the AD75M□, this data is called "Positioning start information".)		
Start history	The configuration of start information and start No. is changed so that the start No. can be directly checked.		
Detailed parameters “Pr.15 Software stroke limit valid/ invalid setting”		AD75M□	QD75M□
	0 (Factory setting)	Software stroke limits invalid for manual operation	Software stroke limits valid for manual operation
	1	Software stroke limits valid for manual operation	Software stroke limits invalid for manual operation

7.5.3 I/O signal comparison to programmable controller CPU

Sequence program change is required as the I/O signals differ.

For details of the I/O signals or sequence program, refer to the Type QD75M Positioning Module User's Manual.

Input (X)			Output (Y)		
Signal name	AD75M□	QD75M□	Signal name	AD75M□	QD75M□
(QD75/AD75) READY	X00*	X00*	Axis 1 Positioning start	Y10	Y10
Axis 1 Start complete	X01	X10	Axis 2 Positioning start	Y11	Y11
Axis 2 Start complete	X02	X11	Axis 3 Positioning start	Y12	Y12
Axis 3 Start complete	X03	X12	Axis 4 Positioning start	-	Y13
Axis 4 Start complete	-	X13	Axis 1 Stop	Y13	Y04
Axis 1 BUSY	X04	X0C	Axis 2 Stop	Y14	Y05
Axis 2 BUSY	X05	X0D	Axis 3 Stop	Y1C	Y06
Axis 3 BUSY	X06	X0E	Axis 4 Stop	-	Y07
Axis 4 BUSY	-	X0F	All axes servo ON	Y15	Y01
Axis 1 Positioning complete	X07	X14	Axis 1 Forward run JOG start	Y16	Y08
Axis 2 Positioning complete	X08	X15	Axis 1 Reverse run JOG start	Y17	Y09
Axis 3 Positioning complete	X09	X16	Axis 2 Forward run JOG start	Y18	Y0A
Axis 4 Positioning complete	-	X17	Axis 2 Reverse run JOG start	Y19	Y0B
Axis 1 Error detection	X0A	X08	Axis 3 Forward run JOG start	Y1A	Y0C
Axis 2 Error detection	X0B	X09	Axis 3 Reverse run JOG start	Y1B	Y0D
Axis 3 Error detection	X0C	X0A	Axis 4 Forward run JOG start	-	Y0E
Axis 4 Error detection	-	X0B	Axis 4 Reverse run JOG start	-	Y0F
Axis 1 M code ON	X0D	X04	Programmable controller READY	Y1D	Y00
Axis 2 M code ON	X0E	X05	Axis 1 Execution prohibition flag	-	Y14
Axis 3 M code ON	X0F	X06	Axis 2 Execution prohibition flag	-	Y15
Axis 4 M code ON	-	X07	Axis 3 Execution prohibition flag	-	Y16
Synchronization flag	-	X01	Axis 4 Execution prohibition flag	-	Y17
Not used	X10 to X1F	X02, X03 X18 to X1F	Not used	Y00 to Y0F Y1E to Y1F	Y02, Y03 Y18 to Y1F

* The ON/OFF statuses for READY are different between the QD75M□/ and AD75M□.

	Not READY/WDT error	READY
QD75M□	OFF	ON
AD75M□	ON	OFF

7.5.4 Buffer memory address comparison

Sequence program change is required as the assignment of buffer memory differs.

For details of the buffer memory or sequence program, refer to the Type QD75M Positioning Module User's Manual.

area shows the differences between AD75M□ and QD75M□.

Item of AD75M□	Buffer memory address					
	AD75M□			QD75M□		
	Axis 1	Axis 2	Axis 3	Axis 1	Axis 2	Axis 3
Pr.1 Unit setting	0	150	300	0	150	300
Pr.2 No. of pulses per rotation (AP)	1	151	301	2	152	302
				3	153	303
Pr.3 Movement amount per rotation (AL)	2	152	302	4	154	304
				5	155	305
Pr.4 Unit magnification (AM)	3	153	303	1	151	301
Pr.7 Speed limit value	6	156	306	10	160	310
	7	157	307	11	161	311
Pr.8 Acceleration time 0	8	158	308	12	162	312
	9	159	309	13	163	311
Pr.9 Deceleration time 0	10	160	310	14	164	314
	11	161	311	15	165	315
Pr.10 Bias speed at start	12	162	312	6	156	306
	13	163	313	7	157	307
Pr.12 Backlash compensation amount	15	165	315	17	167	317
Pr.13 Software stroke limit upper limit value	16	166	316	18	168	318
	17	167	317	19	169	319
Pr.14 Software stroke limit lower limit value	18	168	318	20	170	320
	19	169	319	21	171	321
Pr.15 Software stroke limit selection	20	170	320	22	172	322
Pr.16 Software stroke limit valid/invalid setting	21	171	321	23	173	323
Pr.17 Command in-position width	22	172	322	24	174	324
	23	173	323	25	175	325
Pr.18 Torque limit setting value	24	174	324	26	176	326
Pr.19 M code ON signal output timing	25	175	325	27	177	327
Pr.20 Speed switching mode	26	176	326	28	178	328
Pr.21 Interpolation speed designation method	27	177	327	29	179	329
Pr.22 Current feed value during speed control	28	178	328	30	180	330
Pr.23 Manual pulse generator selection	29	179	329	33	-	-
Pr.25 Size selection for acceleration/ deceleration time	31	181	331	-	-	-
Function selection for speed-positioning	-	-	-	34	184	334
Pr.26 Acceleration time 1	36	186	336	36	186	336
	37	187	337	37	187	337
Pr.27 Acceleration time 2	38	188	338	38	188	338
	39	189	339	39	189	339
Pr.28 Acceleration time 3	40	190	340	40	190	340
	41	191	341	41	191	341

Item of AD75M□	Buffer memory address					
	AD75M□			QD75M□		
	Axis 1	Axis 2	Axis 3	Axis 1	Axis 2	Axis 3
Pr.29 Deceleration time 1	42	192	342	42	192	342
	43	193	343	43	193	343
Pr.30 Deceleration time 2	44	194	344	44	194	344
	45	195	345	45	195	345
Pr.31 Deceleration time 3	46	196	346	46	196	346
	47	197	347	47	197	347
Pr.32 JOG Speed limit value	48	198	348	48	198	348
	49	199	349	49	199	349
Pr.33 JOG operation acceleration time selection	50	200	350	50	200	350
Pr.34 JOG operation deceleration time selection	51	201	351	51	201	351
Pr.35 Acceleration/deceleration process selection	52	202	352	52	202	352
Pr.36 S-pattern proportion	53	203	353	53	203	353
Pr.37 Sudden stop deceleration time	54	204	354	54	204	354
	55	205	355	55	205	355
Pr.38 Stop group 1 sudden stop selection	56	206	356	56	206	356
Pr.39 Stop group 2 sudden stop selection	57	207	357	57	207	357
Pr.40 Stop group 3 sudden stop selection	58	208	358	58	208	358
Pr.41 Positioning complete signal output time	59	209	359	59	209	359
Pr.42 Allowable circular interpolation error width	60	210	360	60	210	360
	61	211	361	61	211	361
Pr.43 External start function selection	62	212	362	62	212	362
(QD75M□: Pr.42 External command function selection)						
Pr.150 Restart allowable range when servo OFF to ON	64	214	364	64	214	364
	65	215	365	65	215	365
Pr.44 Near pass mode selection for path control	66	216	366	-	-	-
Pr.45 OPR method	70	220	370	70	220	370
Pr.46 OPR direction	71	221	371	71	221	371
Pr.47 OP address	72	222	372	72	222	372
	73	223	373	73	223	373
Pr.48 OPR speed	74	224	374	74	224	374
	75	225	375	75	225	375
Pr.49 Creep speed	76	226	376	76	226	376
	77	227	377	77	227	377
Pr.50 OPR retry	78	228	378	78	228	378
OPR dwell time	-	-	-	79	229	379
Pr.52 Setting for the movement amount after near-point dog ON	80	230	380	80	230	380
	81	231	381	81	231	381
Pr.53 OPR acceleration time selection	82	232	382	82	232	382
Pr.54 OPR deceleration time selection	83	233	383	83	233	383
Pr.55 OP shift amount	84	234	384	84	234	384
	85	235	385	85	235	385
Pr.56 OPR torque limit value	86	236	386	86	236	386

Item of AD75M□	Buffer memory address					
	AD75M□			QD75M□		
	Axis 1	Axis 2	Axis 3	Axis 1	Axis 2	Axis 3
Pr.57 Speed designation during OP shift	88	238	388	88	238	388
Pr.58 Dwell time during OPR retry	89	239	389	89	239	389
Pr.59 Absolute position restoration selection	91	241	391	-	-	-
Pr.100 Servo series	100	250	400	30100	30200	30300
Pr.101 Amplifier setting	101	251	401	30101	30201	30301
Pr.102 Regenerative brake resistor	102	252	402	30102	30202	30302
Pr.103 Motor type	103	253	403	30103	30203	30303
Pr.104 Motor capacity	104	254	404	30104	30204	30304
Pr.105 Servo motor speed	105	255	405	30105	30205	30305
Pr.106 Feed back pulse	106	256	406	30106	30206	30306
Pr.107 Rotation direction selection	107	257	407	30107	30207	30307
Pr.108 Auto tuning	108	258	408	30108	30208	30308
Pr.109 Servo response	109	259	409	30109	30209	30309
Maker setting	-	-	-	30110	30210	30310
Maker setting	-	-	-	30111	30211	30311
Pr.112 Load inertia ratio	112	262	412	30112	30212	30312
Pr.113 Position loop gain 1	113	263	413	30113	30213	30313
Pr.114 Speed loop gain 1	114	264	414	30114	30214	30314
Pr.115 Position loop gain 2	115	265	415	30115	30215	30315
Pr.116 Speed loop gain 2	116	266	416	30116	30216	30316
Pr.117 Speed integral compensation	117	267	417	30117	30217	30317
Pr.118 Notch filter selection	118	268	418	30118	30218	30318
Pr.119 Feed forward gain	119	269	419	30119	30219	30319
Pr.120 In-position range	120	270	420	30120	30220	30320
Pr.121 Electromagnetic brake sequence output	121	271	421	30121	30221	30321
Pr.122 Analog monitor output	122	272	422	30122	30222	30322
Pr.123 Optional function 1	123	273	423	30123	30223	30323
Pr.124 Optional function 2	124	274	424	30124	30224	30324
Pr.125 Adaptive vibration suppression control/ low pass filter	125	275	425	30125	30225	30325
Pr.126 Maker setting	-	-	-	30126	30226	30326
Pr.127 Monitor output 1 offset	127	277	427	30127	30227	30327
Pr.128 Monitor output 2 offset	128	278	428	30128	30228	30328
Pr.129 Pre-alarm data selection	129	279	429	30129	30229	30329
Pr.130 Zero speed	130	280	430	30130	30230	30330
Pr.131 Error excessive alarm level	131	281	431	30131	30231	30331
Pr.132 Optional function 5	132	282	432	30132	30232	30332
Pr.133 Optional function 6	133	283	433	30133	30233	30333
Pr.134 PI-PID control switch-over position droop	134	284	434	30134	30234	30334

Item of AD75M□	Buffer memory address					
	AD75M□			QD75M□		
	Axis 1	Axis 2	Axis 3	Axis 1	Axis 2	Axis 3
Maker setting	-	-	-	30135	30235	30335
Pr.136 Speed differential compensation	136	286	436	30136	30236	30336
Pr.137 Maker setting	-	-	-	30137	30237	30337
Pr.138 Encoder output pulses	138	288	438	30138	30238	30338
Pr.149 Servo parameter transmission setting	149	299	449	-	-	-
Maker setting	-	-	-	30139	30239	30339
Maker setting	-	-	-	30140	30240	30340
Maker setting	-	-	-	30141	30241	30341
Slight vibration suppression control selection 1	-	-	-	30143	30243	30343
Slight vibration suppression control selection 2	-	-	-	30144	30244	30344
Induction voltage compensation	-	-	-	30145	30245	30345
Maker setting	-	-	-	30146	30246	30346
Maker setting	-	-	-	30147	30247	30347
Maker setting	-	-	-	30148	30248	30348
Gain changing selection	-	-	-	30149	30249	30349
Gain changing condition	-	-	-	30150	30250	30350
Gain changing time constant	-	-	-	30151	30251	30351
Ratio of load inertia moment to servomotor inertia moment 2	-	-	-	30152	30252	30352
Position loop gain 2 changing ratio	-	-	-	30153	30253	30353
Speed loop gain 2 changing ratio	-	-	-	30154	30254	30354
Speed integral compensation changing ratio	-	-	-	30155	30255	30355
Maker setting	-	-	-	30156	30256	30356
Maker setting	-	-	-	30157	30257	30357
Maker setting	-	-	-	30158	30258	30358
Maker setting	-	-	-	30159	30259	30359
Optional function C	-	-	-	30160	30260	30360
Machine resonance suppression filter	-	-	-	30161	30261	30361
Maker setting	-	-	-	30162	30262	30362
Maker setting	-	-	-	30163	30263	30363
Maker setting	-	-	-	30164	30264	30364
Maker setting	-	-	-	30165	30265	30365
Maker setting	-	-	-	30166	30266	30366

Item of AD75M□	Buffer memory address	
	AD75M□	QD75M□
	Common for axis 1,2,3	Common for axis 1,2,3,4
[Md.1] In test mode flag	450	1200
[Md.2] Module name	451	-
[Md.3] OS type	452 453 454 455	-
[Md.4] OS version	456 457	-
[Md.5] Clock data (hour: minute)	460	-
[Md.6] Clock data (second: 100 ms)	461	-
(Pointer number)	(0) to (15)	
[Md.7] Start axis (QD75M□: [Md.3] Start information)	462 to 537	1212 to 1287
[Md.8] Operation type (QD75M□: [Md.4] Start No.)	463 to 538	1213 to 1288
[Md.9] Start Hour: minute (QD75M□: [Md.5] Start Hour)	464 to 539	1214 to 1289
[Md.10] Start Second: 100 ms (QD75M□: [Md.6] Start Minute: second)	465 to 540	1215 to 1290
[Md.11] Error judgment	466 to 541	1216 to 1291
[Md.12] Start history pointer	542	1292
(Pointer number)	(0) to (15)	
[Md.13] Start axis	543 to 618	-
[Md.14] Operation type	544 to 619	-
[Md.15] Start Hour: minute	545 to 620	-
[Md.16] Start Second: 100 ms	546 to 621	-
[Md.17] Error judgment	547 to 622	-
[Md.18] Start history pointer at error	623	-
(Pointer number)	(0) to (15)	
[Md.19] Axis in which the error occurred	624 to 684	1293 to 1353
[Md.20] Axis error No.	625 to 685	1294 to 1354
[Md.21] Axis error occurrence Hour: minute (QD75M□: [Md.11] Axis error occurrence (Hour))	626 to 686	1295 to 1355
[Md.22] Axis error occurrence Second: 100 ms (QD75M□: [Md.12] Axis error occurrence (Minutes: second))	627 to 687	1296 to 1356
[Md.23] Error history pointer	688	1357

Item of AD75M□	Buffer memory address	
	AD75M□	QD75M□
	Common for axis 1,2,3	Common for axis 1,2,3,4
(Pointer number)	(0) to (15)	
[Md.24] Axis in which the warning occurred	689 to 749	1358 to 1418
[Md.25] Axis warning No.	690 to 750	1359 to 1419
[Md.26] Axis warning occurrence Hour: minutes	Warning history	(0) to (15)
(QD75M□: [Md.16] Axis warning occurrence (Hour))		
[Md.27] Axis warning occurrence Second: 100 ms	691 to 751	1360 to 1420
(QD75M□: [Md.17] Axis warning occurrence (Minutes: second))	692 to 752	1361 to 1421
[Md.28] Warning history pointer	753	1422

Item of AD75M□	Buffer memory address					
	AD75M□			QD75M□		
	Axis 1	Axis 2	Axis 3	Axis 1	Axis 2	Axis 3
Md.29 Current feed value	800	900	1000	800	900	1000
	801	901	1001	801	901	1001
Md.30 Machine feed value	802	902	1002	802	902	1002
	803	903	1003	803	903	1003
Pr.31 Feedrate	804	904	1004	804	904	1004
	805	905	1005	805	905	1005
Md.32 Valid M code	806	906	1006	808	908	1008
Md.33 Axis error No.	807	907	1007	806	906	1006
Md.34 Axis warning No.	808	908	1008	807	907	1007
Md.35 Axis operation status	809	909	1009	809	909	1009
Md.36 Current speed	810	910	1010	810	910	1010
				811	911	1011
Md.37 Axis feedrate	812	912	1012	812	912	1012
	813	913	1013	813	913	1013
Md.38 Speed-position switching control positioning amount	814	914	1014	814	914	1014
	815	915	1015	815	915	1015
Md.39 External input/output signal	816	916	1016	816	916	1016
Md.40 Status	817	917	1017	817	917	1017
Md.41 Target value	818	918	1018	818	918	1018
	819	919	1019	819	919	1019
Md.42 Target speed	820	920	1020	820	920	1020
	821	921	1021	821	921	1021
Md.43 OP absolute position	822	922	1022	-	-	-
	823	923	1023			
Md.44 Movement amount after near-point dog ON	824	924	1024	824	924	1024
	825	925	1025	825	925	1025
Md.45 Torque limit stored value	826	926	1026	826	926	1026
Md.46 Special start data instruction code setting value	827	927	1027	827	927	1027
Md.47 Special start data instruction parameter setting value	828	928	1028	828	928	1028
Md.48 Start positioning data No. setting value	829	929	1029	829	929	1029
Md.49 In speed control flag	830	930	1030	830	930	1030
Md.50 In speed change processing flag	831	931	1031	831	931	1031
Md.51 Start data pointer being executed	832	932	1032	834	934	1034
Md.52 Last executed positioning data No.	833	933	1033	837	937	1037
Md.53 Repetition counter						
(QD75M□: Md.41 Special start repetition counter)	834	934	1034	832	932	1032
Md.54 Positioning data No. being executed	835	935	1035	835	935	1035
Md.55 Block No. being executed	836	936	1036	836	936	1036
Md.56 Positioning data being executed	838 to 847	938 to 947	1038 to 1047	838 to 847	938 to 947	1038 to 1047
Md.100 OPR re-travel value	848	948	1048	848	948	1048
	849	949	1049	849	949	1049
Md.101 Real current value	850	950	1050	850	950	1050
	851	951	1051	851	951	1051

Item of AD75M□	Buffer memory address					
	AD75M□			QD75M□		
	Axis 1	Axis 2	Axis 3	Axis 1	Axis 2	Axis 3
Md.102 Deviation counter value	852	952	1052	852	952	1052
	853	953	1053	853	953	1053
Md.103 Motor rotation	854	954	1054	854	954	1054
	855	955	1055	855	955	1055
Md.104 Motor current value	856	956	1056	856	956	1056
Md.105 Auto tuning	857	957	1057	857	957	1057
Md.106 Load inertia ratio	858	958	1058	858	958	1058
Md.107 Position loop gain 1	859	959	1059	859	959	1059
Md.108 Speed loop gain 1	860	960	1060	860	960	1060
Md.109 Position loop gain 2	861	961	1061	861	961	1061
Md.110 Speed loop gain 2	862	962	1062	862	962	1062
Pr.111 Speed integral compensation	863	963	1063	863	963	1063
Md.112 Servo amplifier software No.	864 - 869	964 - 969	1064 - 1069	864 - 869	964 - 969	1064 - 1069
Md.113 Parameter error (No.0 to 15)	870	970	1070	870	970	1070
Md.114 Parameter error (No.16 to 31)	871	971	1071	871	971	1071
Md.115 Parameter error (No.32 to 47)	872	972	1072	872	972	1072
Parameter error (No.48 to 63)	-			873	973	1073
Parameter error (No.64 to 75)	-			874	974	1074
Maker setting	-			875	975	1075
	-			876	976	1076
Md.116 Servo status	873	973	1077	877	977	1077
Md.117 Regenerative load ratio	876	976	1078	878	978	1078
Md.118 Effective load torque	877	977	1079	879	979	1079
Md.119 Peak torque ratio	878	978	1080	880	980	1080
Md.121 Absolute position restoration mode	879	979	1079			
Md.120 FeRAM access count	880 - 883	980 - 983	1080 - 1083			
Deceleration start flag	-			899	999	1099

Item of AD75M□	Buffer memory address					
	AD75M□			QD75M□		
	Axis 1	Axis 2	Axis 3	Axis 1	Axis 2	Axis 3
Cd.1 Clock data setting (hour)	1100			-		
Cd.2 Clock data setting (minute, second)	1101			-		
Cd.3 Clock data writing	1102			-		
Cd.4 Target axis	1103			-		
Cd.5 Positioning data No.	1104			-		
Cd.6 Write pattern	1105			-		
Cd.7 Read/write request	1106			-		
Cd.8 Read/write positioning data I/F	1108 to 1137			-		
Cd.9 Flash ROM write request	1138			1900		
Cd.10 Parameter initialization request	1139			1901		
Cd.11 Positioning start No.	1150	1200	1250	1500	1600	1700
Cd.12 Axis error reset	1151	1201	1251	1502	1602	1702
Cd.13 Restart command	1152	1202	1252	1503	1603	1703
Cd.14 M code OFF request	1153	1203	1253	1504	1604	1704
Cd.15 New current value	1154	1204	1254	1506	1606	1706
	1155	1205	1255	1507	1607	1707
Cd.16 New speed value	1156	1206	1256	1514	1614	1714
	1157	1207	1257	1515	1615	1715
Cd.17 Speed change request	1158	1208	1258	1516	1616	1716
Cd.18 Positioning operation speed override	1159	1209	1259	1513	1613	1713
Cd.19 JOG speed	1160	1210	1260	1518	1618	1718
	1161	1211	1261	1519	1619	1719
Cd.20 Speed-position switching enable flag	1163	1213	1263	1528	1628	1728
Cd.21 Speed-position switching control movement amount change register	1164	1214	1264	1526	1626	1726
	1165	1215	1265	1527	1627	1727
Cd.22 Manual pulse generator enable flag	1167	1217	1267	1524	1624	1724
Cd.23 Manual pulse generator 1 pulse input magnification	1168	1218	1268	1522	1622	1722
	1169	1219	1269	1523	1623	1723
Cd.24 OPR return request flag OFF request	1170	1220	1270	1521	1621	1721
Cd.25 External start valid	1171	1221	1271	1505	1605	1705
(QD75M□: Cd.8 External command valid)						
Cd.26 Step valid flag	1172	1222	1272	1545	1645	1745
Cd.27 Step mode	1173	1223	1273	1544	1644	1744
Cd.28 Step start information	1174	1224	1274	1546	1646	1746
Cd.29 Skip command	1175	1225	1275	1547	1647	1747
Cd.30 New torque value	1176	1226	1276	1525	1625	1725
Cd.31 Positioning starting point No.	1178	1228	1278	1501	1601	1701
Cd.100 Servo OFF command	1179	1229	1279	1551	1651	1751
Cd.101 Torque output setting value	1180	1230	1280	1552	1652	1752

Item of AD75M□	Buffer memory address					
	AD75M□			QD75M□		
	Axis 1	Axis 2	Axis 3	Axis 1	Axis 2	Axis 3
Cd.32 Interrupt request during continuous operation	1181	1231	1281	1520	1620	1720
Cd.33 New acceleration time value	1184	1234	1284	1508	1608	1708
	1185	1235	1285	1509	1609	1709
Cd.34 New deceleration time value	1186	1236	1286	1510	1610	1710
	1187	1237	1287	1511	1611	1711
Cd.35 Acceleration/deceleration time change during speed change, enable/disable selection	1188	1238	1288	1512	1612	1712
Deceleration start flag valid	-			1905		
Stop command processing for deceleration stop selection	-			1907		
Servo amplifier data read	-			1553	1653	1753

Item of AD75M□		Buffer memory address																								
		AD75M□						QD75M□																		
		Axis 1		Axis 2		Axis 3		Axis 1		Axis 2		Axis 3														
Positioning data*1	Da.1 Operation pattern	No.1	1300		2300		3300		2000		8000		14000													
	Da.2 Control system																									
	Da.3 Acceleration time No.																									
	Da.4 Deceleration time No.																									
	Da.9 M code/condition data		1301		2301		3301		2001		8001		14001													
	Da.8 Dwell time/JUMP destination positioning data No.		1302		2302		3302		2002		8002		14002													
	Empty		1303		2303		3303		2003		8003		14003													
	Da.7 Command speed		1304		2304		3304		2004		8004		14004													
	Da.5 Positioning address/movement amount		1305		2305		3305		2005		8005		14005													
			1306		2306		3306		2006		8006		14006													
	Da.6 Arc address		1307		2307		3307		2007		8007		14007													
			1308		2308		3308		2008		8008		14008													
	No.2		1309		2309		3309		2009		8009		14009													
	No.2		1310 to 1319		2310 to 2319		3310 to 3319		2010 to 2019		8010 to 8019		14010 to 14019													
No.3	1320 to 1329		2320 to 2329		3320 to 3329		2020 to 2029		8020 to 8029		14020 to 14029															
to	to		to		to		to		to		to															
No.100	2290 to 2299		3290 to 3299		4290 to 4299		2990 to 2999		8990 to 8999		14990 to 14999															
Start block data*2	Da.10 Shape	1st point	4300 4350		4550 4600		4800 4850		26000 26050		27000 27050		28000 28050													
	Da.11 Start data No.																									
	Da.12 Special start instruction																									
	Da.13 Parameter																									
	2nd point		4301 4351		4551 4601		4801 4851		26001 26051		27001 27051		28001 28051													
	3rd point		4302 4352		4552 4602		4802 4852		26002 26052		27002 27052		28002 28052													
	to		to		to		to		to		to		to													
	50th point		4349 4399		4599 4649		4849 4899		26049 26099		27049 27099		28049 28099													
	Condition data		Da.14 Condition target	No.1	4400		4650		4900		26100		27100		28100											
			Da.15 Condition operator																							
Da.16 Address		4402															4652		4902		26102		27102		28102	
		4403															4653		4903		26103		27103		28103	
Da.17 Parameter 1		4404			4654		4904		26104		27106		28106													
		4405			4655		4905		26105		27107		28107													
Da.18 Parameter 2		4406			4656		4906		26106		27106		28106													
		4407			4657		4907		26107		27107		28107													
No.2		4410 to 4419			4660 to 4669		4910 to 4919		26110 to 26119		27110 to 27119		28110 to 28119													
No.3		4420 to 4429			4670 to 4679		4920 to 4929		26120 to 26129		27120 to 27129		28120 to 28129													
to	to		to		to		to		to		to															
No.10	4490 to 4499		4740 to 4749		4990 to 4999		26190 to 26199		27190 to 27199		28190 to 28199															

*1 With the QD75M□, the positioning data buffer memory addresses are Nos. 1 to 600.

*2 With the QD75M□, it is called "block start data".

*3 With the QD75M□, the [block start data] and [condition data] in the area are called [start block 0]. There are five start blocks: 0 to 4

Item of AD75M□			Buffer memory address					
			AD75M□			QD75M□		
			Axis 1	Axis 2	Axis 3	Axis 1	Axis 2	Axis 3
Positioning start information	Indirect designation	Start No.8001	4500	4750	5000	-	-	-
		Start No.8002	4501	4751	5001	-	-	-
		to	to	to	to	to	to	
		Start No.8050	4549	4799	5049	-	-	-
Programmable controller CPU memory area	Condition judgment target data of the condition data		5050			30000		
			to			to		
			5099			30099		
Target axis			5100			-		
Head positioning block No.			5101			-		
No. of read/write data items			5102			-		
Read/write request			5103			-		
Read/write block			5110 to 6109			-		

7.5.5 Interface specifications comparison with external devices

For the external interface specifications, the following shows the differences between AD75M□ and QD75M□.

(1) Comparison of electrical specifications

○ : Compatible, △ : Partial change required

Item		Differences as Interface specifications*	compati- bility	Precautions for replacement
Input	Upper/lower limit signal	OFF current: 1.5mA→1.0mA Input resistance: 4.7kΩ→6.8kΩ	△	Check whether the OFF current value met satisfied values
	Stop signal	OFF current: 1.5mA→1.0mA Input resistance: 4.7kΩ→6.8kΩ	△	Check whether the OFF current value met satisfied values
	Near-point dog signal	OFF current: 1.5mA→1.0mA Input resistance: 4.7kΩ→6.8kΩ Response time: 4ms→1ms	△	Check whether the OFF current value met satisfied values
	Speed-position switching signal	OFF current: 1.5mA→1.0mA Input resistance: 4.7kΩ→6.8kΩ Response time: 4ms→1ms	△	Check whether the OFF current value met satisfied values
	Manual pulse generator	ON current: 3.5mA→1.0mA Input resistance: 1.5k→1.2kΩ	○	

* The column of interface specifications differences is described as the form, [Specifications of AD75M□] → [Specifications of QD75M□].

(2) Comparison of connector signal sequence

When using with QD75M□, change the connector and wiring.

Name	AD75M□		QD75M□	
	Logic (Initial setting)	Logic switching by parameter	Logic (Initial setting)	Logic switching by parameter
Manual pulse generator A phase	Negative logic	Not allowed	Negative logic	Allowed
Manual pulse generator B phase* ¹	Negative logic (multiple of 4)	Not allowed	Negative logic (multiple of 4)	Allowed
Near-Point signal	Negative logic	Not allowed	Negative logic	Allowed
Stop signal	Negative logic	Not allowed	Negative logic	Allowed
Upper limit	Negative logic	Not allowed	Negative logic	Allowed
Lower limit	Negative logic	Not allowed	Negative logic	Allowed
External start* ²	Negative logic	Not allowed	Negative logic	Allowed
Speed-position switching signal* ²	Negative logic	Not allowed		

*¹ The following shows comparisons about manual pulse generator A phase/B phase.

	AD75M□	QD75M□
No. of connection	1 generator/axis	1 generator/module
Mode change (Parameter)	Not allowed	Allowed 1 x mode, 2 x mode, 4 x mode, PLS/SIGN mode

*² With the QD75M□, the "external start signal" and "speed-position switching signal" are combined into the "external command signal/switching signal".

(3) Supported servo amplifier

(a) For continuous use of a servo amplifier connected with the existing AD75M

The following table shows whether or not the existing servo amplifier can be continuously used with positioning modules replaced.

AD75M□ Supported amplifier model	QD75M□ Availability	Remarks
MR-J□-B	Available	<ul style="list-style-type: none"> Needs to change the SSCNET cables (refer to (b) in the next page.) Discontinued model
MR-H□-B	Available	
MR-J2□-B	Available	
MR-J2S□-B	Available	<ul style="list-style-type: none"> Needs to change the SSCNET cables (refer to (b) in the next page.) Model to be discontinued at the end of September 2015

☒ Point

- (1) Selecting suitable products to replace the existing servo amplifier
 When replacing the existing servo amplifier, select a positioning module in the following combinations.
 Additionally, the servo motor needs to be replaced.
 - Positioning module: QD77MS□ + servo amplifier: MR-J3□-B
 - Positioning module: QD77MS□ + servo amplifier: MR-J4□-B

- (2) Selecting suitable products to replace the existing servo amplifier without servo motor replacement
 When replacing the existing servo amplifier alone without servo motor replacement, select a module in the following combination.
 - Positioning module: QD75M
 - + Servo amplifier: MR-J4-B-RJ020
(Conversion Unit for SSCNET of MR-J2S-B Compatible Servo Amplifier)
 - + Converter module: MR-J4-T20
(Conversion Unit for SSCNET of MR-J2S-B)

For replacing servo amplifiers and servo motors, data such as positioning parameters and positioning data need to be changed.

When replacing them, contact the department in charge of Mitsubishi electric servo products.

For replacing the MR-J2S□-B, refer to "Transition from MELSERVO-J2-Super/J2M Series to J4 Series Handbook" (L(NA)03093).

(b) For SSCNET cables applicable to the servo amplifiers

The following tables show applicable SSCNET cables when the existing servo amplifier is continuously used.

Replacing positioning modules from the AD75M to the QD75M requires the change of SSCNET cables.

Table 1. With the servo amplifier MR-J, J2, or J2S

SSCNET cable		Between QD75 and MR-J/J2/J2S amplifier	Between AD75 and MR-J/J2/J2S amplifier	Between MR-J/J2/J2S amplifier and MR-J/J2/J2S amplifier
MR-J2HBUS□M		○	×	○
MR-J2HBUS□M-A		×	○	×
MR-HBUS□M		×	×	×
MR-J2CN1	*1	○	×	○
MR-J2CN1-A		×	○	×
MR-HBCNS		×	×	×

*1 Connector set for making the cable by user

Table 2. With the servo amplifier MR-H

SSCNET cable		Between QD75M and MR-H amplifier	Between AD75M and MR-H amplifier	Between MR-H amplifier and MR-H amplifier
MR-J2HBUS□M		×	×	×
MR-J2HBUS□M-A		○	×	×
MR-HBUS□M		×	○	○
MR-J2CN1	*1	×	×	×
MR-J2CN1-A		○	×	×
MR-HBCNS		×	○	○

*1 Connector set for making the cable by user

7.6 AD70

7.6.1 Performance specifications comparison

○ : Compatible, △ : Partial change required, × : Incompatible

Model		AD70	QD73A1	Compat- ibility	Precautions for replacement
Item					
Number of control axes		1 axis	1 axis	○	
Positioning data	Capacity	1 data	1 data	○	
	Setting method	Sequence program	Sequence program	○	
Positioning	Mode	Position control mode (Positioning, two-phase trapezoidal positioning) Speed-position control switch mode	Position control mode (Positioning, two-phase trapezoidal positioning) Speed-position control switch mode	○	
	System	Position control mode: Absolute system/incremental system Speed-position control switch mode: Incremental system	Position control mode: Absolute system/incremental system Speed-position control switch mode: Incremental system	○	
	Position command	-2147483648 to 2147483647 (pulse) (32-bit signed binary)	-2147483648 to 2147483647 (pulse) (32-bit signed binary)	○	
	Speed command	1 to 400,000 (pulse/s)	1 to 4,000,000 (pulse/s)	○	The specification has improved. (Upward-compatibility)
	Acceleration/ deceleration	Automatic trapezoidal acceleration/ deceleration	Automatic trapezoidal acceleration/ deceleration	○	
	Automatic acceleration/ deceleration	Acceleration time: 2 to 9999 (ms) Deceleration time: 2 to 9999 (ms)	Acceleration time: 2 to 9999 (ms) Deceleration time: 2 to 9999 (ms)	○	
	In-position range	1 to 2047 pulse	1 to 20479 pulse	○	The specification has improved. (Upward-compatibility)
	Backlash compensation	×	×	○	
	Error correction function	×	×	○	
Speed command output		0 to ±10VDC (Adjustable to set in the range of ±5 to ±10VDC)	0 to ±10VDC (Adjustable to set in the range of ±5 to ±10VDC)	○	
Positioning feedback pulse input	Pulse frequency	Open collector : 100kpulse/s TTL: 100kpulse/s Differential output: 100kpulse/s	Open collector: 200kpulse/s TTL: 200kpulse/s Differential output: 1Mpulse/s	○	The specification has improved. (Upward-compatibility)
	Connectable encoder type	Open collector, TTL, or differential output	Open collector, TTL, or differential output	○	
	Multiplication setting	The number of input feedback pulses can be multiplied by 4, 2, 1, or 1/2.	The number of input feedback pulses can be multiplied by 4, 2, 1, or 1/2.	○	
OPR control		Available (2 method)	Available (2 method)	○	The setting method is changed from a hardware switch to PLC parameter of a CPU module. The function is the same though the setting method is changed.
JOG operation		○	○	○	
Starting time		Absolute system: 4.4ms ^{*1} Incremental system: 4.5ms ^{*1} JOG operation: 4.3ms OPR (near-point dog method): 4.4ms OPR (count method): 5.1ms	Absolute system: 1.2ms ^{*1} Incremental system: 1.2ms ^{*1} JOG operation: 1.2ms OPR (near-point dog method): 1.2ms OPR (count method): 1.2ms	○	The specification has improved. (Upward-compatibility)
M function		×	×	○	

○ : Compatible, △ : Partial change required, ✕ : Incompatible

Item	Model AD70	QD73A1	Compat- ibility	Precautions for replacement
Internal current consumption (5VDC)	5VDC 0.3A	5VDC 0.52A	△	The recalculation of internal current consumption (5VDC) is required.
External supply voltage/ current terminal block	+15VDC, 0.2A -15VDC, 0.02A	--	○	An external power supply is not required.
Number of occupied I/O points	32 points (Number of I/O slots: 1 slot occupied) (I/O assignment: 32 points, special function module)	48 points (Number of I/O slots: 2 slots occupied) (I/O assignment: First half 16 points, empty slot, Second half 32 points, intelligent function module)	△	The number of occupied slots and I/O points are changed.*2
Weight	0.4kg	0.2kg	○	

- *1 For the AD70, 0.2ms is added to the starting time in two-phase trapezoidal positioning mode. For the QD73A1, an extra time is not added even in two-phase trapezoidal positioning mode.
- *2 For the QD73A1, the number of occupied slots is 2 and the number of occupied I/O points is 48. The program can be utilized easily by setting Empty 0 point to the first half slot of the QD73A1, or by setting the XY address of the AD70 to the second half slot of the QD73A1 at Start XY in I/O assignment of PLC parameter.

7.6.2 Function comparison

(1) Function comparison between the AD70 and the QD73A1

○: Compatible, --: Not available

Function		Description	AD70	QD73A1	Precautions for replacement
Major positioning control	Positioning control	Positioning is executed from the current position to a specified position at a specified speed.	○	○	Refer to Section 7.6.6.
	Position control mode	Positioning is executed to the address specified in "Da.2] Positioning address P1" at "Da.3] Positioning speed V1", then to the address specified in "Da.4] Positioning address P2" at "Da.5] Positioning speed V2" by one positioning start signal.	○	○	
	Speed-position control switch mode	Operation starts according to the positioning speed set beforehand by one start signal, then the operation switches to position control by Speed-position switching command signal. If the operation stopped by Stop signal after the input of Speed-position switching command signal, the positioning can be continued by Speed-position mode restart signal. In addition, the positioning address (movement amount) can be changed if it is before the input of Speed-position switching command signal.	○	○	Refer to Section 7.6.6.
JOG operation		Positioning is executed in the specified direction at specified speed while a JOG operation command is on. Turning on the signal starts operation at a specified speed and speed control operation is continued until Stop signal is input.	○	○	
OPR control		A workpiece is returned to an original point following an OPR start command from a CPU module, and the current value is corrected to an OP address after the completion of OPR.	○	○	
Multiplication setting		This function multiplies the feedback pulse frequency from the pulse generator by 4, 2, 1, or 1/2.	○	○	
Electronic gear function		This function controls moving distance and speed by multiplying command pulse output.	○	○	
Deviation counter clear function		This function clears the accumulated pulses in the deviation counter. When the servomotor power is turned off due to an emergency stop during positioning, clearing the accumulated pulses in the deviation counter prevents servomotor rotation at power recovery.	○	○	
Speed change function		This function forces to change speed from a program during positioning control or JOG operation.	○	○	Refer to Section 7.6.6.
Current value change function		This function changes the current feed value to a specified value from a sequence program on the condition other than while BUSY.	○	○	Refer to Section 7.6.6.
In-position function		This function turns on In-position signal while the accumulated pulse amount in the deviation counter is within the specified in-position range. In-position signal can be used as the signal right before positioning completion.	○	○	
Zero/gain adjustment		This function adjusts analog voltage contained in accumulated pulses.	○	○	Refer to Section 7.6.6.

Remarks

Positioning execution time (BUSY signal (X14) ON to Positioning complete signal (X15) ON) of the QD73A1 and AD70 may differ because their internal processing methods are different. As a result, the timing when In-position signal (X16) turns on may also vary.

Adjust positioning execution time using the following methods if the difference of the positioning execution time (or the timing when In-position signal (X16) turns on) affects the system.

- Adjusting the QD73A1's positioning parameter, "[Pr.6] Acceleration time" or "[Pr.7] Deceleration time".
- Increasing gain by changing the accumulated pulse amount setting through the QD73A1's zero/gain adjustment

(2) Changed function from the AD70

Though the functions of the AD70 and the QD73A1 are same, the setting methods and buffer memory addresses for the functions are partly changed.

To use following functions, changes or corrections of the programs or setting methods are required. For details, refer to the user's manual for the QD73A1.

Changed function	Change description
Major positioning control	Program corrections of the QD73A1 are required because buffer memory addresses for the positioning address, positioning speed, and positioning pattern differ from those of the AD70.
Speed-position control switch mode (speed control operation)	<ul style="list-style-type: none"> • AD70 For Velocity/position axis travel distance change area, the value is reflected during speed control. Setting value: 0 to 2147483647 (valid within the stroke range) • QD73A1 For New speed-position movement amount, the value is cleared to 0 when the next operation starts and reflected when Speed-position switching command signal is turned on. Setting value: 1 to 2147483647 (valid within the stroke range)
Speed change function	<ul style="list-style-type: none"> • AD70 The speed change is requested by writing a new speed value in Velocity change area of the buffer memory. • QD73A1 The speed change is requested by writing a new speed value in the buffer memory and writing "1" to Speed change request (buffer memory address: 91). <p>* To use the speed change function, an additional program is required. *1</p>
Current value change function	<ul style="list-style-type: none"> • AD70 The current value is changed by writing a new address in Present value change area of the buffer memory. • QD73A1 The current value is changed by writing a new address in New current value of the buffer memory and writing "1" to Current value change request (buffer memory address: 90).
Zero/gain adjustment	<ul style="list-style-type: none"> • AD70 The adjustment is performed using the volumes for zero/gain adjustment. • QD73A1 The adjustment is performed by either of following methods. 1) Using the UP/DOWN switch for zero/gain adjustment The function is the same as the AD70 though the QD73A1 uses the UP/DOWN switch instead of the volumes. 2) Using the buffer memory To use the buffer memory for the adjustment, create a program.

Changed function	Change description
Mode switch	<ul style="list-style-type: none"> • AD70 The setting is configured with slide switches or encoder interface setting pin (hardware setting) 1) Slide switches Rotation direction, accumulated pulse, multiplication setting, zero-return direction, zero-return mode, and zero/gain adjustment mode setting/clear 2) Encoder interface setting pin Encoder output types • QD73A1 The setting is configured with Switch setting in I/O assignment of PLC parameter (GX Developer). When using GX Works2, set it with the intelligent function module switch setting.) <p>* Though the setting method is changed from a hardware switch to parameters of software, the same level of settings are available because the function is upward compatible.</p>
LED	Refer to *2.

*1 Example of an additional program (using a buffer memory address for the speed change function)

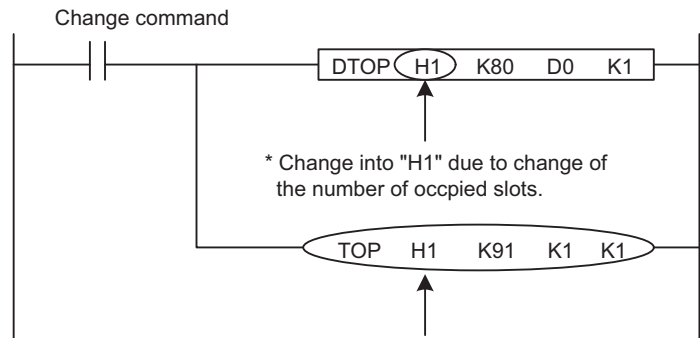

*2 Details of LEDs are shown in the table below.

LED name	AD70	QD73A1	Remarks ^{*3}
RUN	--	RUN	
Minor error	ERR.1	ERR.	Used for both minor errors and major errors.
Major error	ERR.2		
Encoder phase A	φA	φA	
Encoder phase B	φB	φB	
Encoder phase Z	φZ	φZ	
BUSY	BUSY	BUSY	
Zero adjustment status	--	ZERO	The contents indicated with "ZERO" of the QD73A1 differ from the ones indicated with "ZERO" of the AD70.
Gain adjustment status	--	GAIN	
Servo READY	SV RDY	--	Can be checked with an input signal "X1B".
Near-zero point dog	DOG	--	Can be checked with an input signal "X1C".
Stop	STOP	--	Can be checked with an input signal "X1D".
Upper limit LS	FLS	--	Can be checked with an input signal "X1E".
Lower limit LS	RLS	--	Can be checked with an input signal "X1F".
In-Position	IN-POS	--	Can be checked with an input signal "X16".
Error counter polarity	POLE	--	Can be checked with buffer memory addresses "106, 107".
Error counter value	2 ⁿ	--	The LED "POLE" of the AD70 indicates ON when the deviation counter value is "-", and indicates OFF when the deviation counter value is "+".
PC READY	PC RDY	--	Check the on/off status of an output signal "Y2D" with a device monitor.
Zero-return request	ZERO	--	Can be checked with an input signal "X12". The contents indicated with "ZERO" of the AD70 differ from the ones indicated with "ZERO" of the QD73A1.
Excessive error	EEX	--	Can be checked with an input signal "X17".
WDT error	WDT ERR	--	Can be checked with an input signal "X10".
During velocity operation	V-MODE	--	Can be checked with an input signal "X2D".

*3 The I/O signals shown in the table are the ones when the QD73A1 is mounted on the slots "0, 1" of a main base unit. Note that XY addresses of the QD73A1 are different from the ones of the AD70 because the number of occupied slots differs between the modules as shown below.

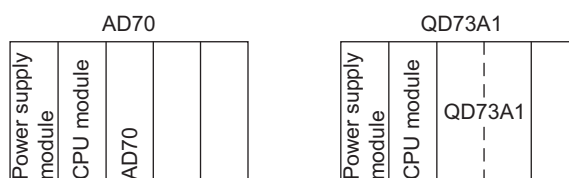

7.6.3 I/O signals comparison to CPU module

An addition or change of a sequence program is required because the I/O signals partly differ between the modules.

For details of the I/O signals or sequence program, refer to the MELSEC-Q QD73A1 Positioning Module User's Manual.

Input (X)			Output (Y)		
Signal name	AD70	QD73A1	Signal name	AD70	QD73A1
Unused (The first half slot is Empty 16 points.)* ¹	--	X00 to X0F	Unused (The first half slot is Empty 16 points.)* ¹	--	Y00 to Y0F
WDT error, H/W error	X00	X10	Zero/gain adjustment data writing request	--	Y1A
Module READY	X01	X11	Zero/gain adjustment change request	--	Y1B
OPR request	X02	X12	Set value change request	--	Y1C
OPR complete	X03	X13	OPR start	Y10	Y20
BUSY	X04	X14	Absolute positioning start	Y11	Y21
Positioning complete	X05	X15	Forward start	Y12	Y22
In-position	X06	X16	Reverse start	Y13	Y23
Excessive error	X07	X17	Forward JOG start	Y14	Y24
Error detection	X08	X18	Reverse JOG start	Y15	Y25
Overflow	X09	X19	Speed-position mode restart	Y16	Y26
Underflow	X0A	X1A	Stop	Y17	Y27
Servo READY	X0B	X1B	Error reset	Y18	Y28
Near-point dog	X0C	X1C	Overflow reset	Y19	Y29
External stop	X0D	X1D	Underflow reset	Y1A	Y2A
Upper limit signal	X0E	X1E	Speed-position switching enable	Y1C	Y2C
Lower limit signal	X0F	X1F	PLC READY	Y1D	Y2D
OPR start complete	--	X20	Use prohibited* ²	Y00 to Y0F	Y10 to Y19
Absolute positioning start complete	--	X21		Y1B	Y1D to Y1F
Forward start complete (for the incremental positioning and the speed-position control switching)	--	X22		Y1E, Y1F	
Reverse start complete (for the incremental positioning and the speed-position control switching)	--	X23		--	Y2E, Y2F
Synchronization flag	--	X24			
Zero/gain adjustment data writing complete flag	--	X2A			
Zero/gain adjustment change complete flag	--	X2B			
Set value change complete flag	--	X2C			
Operating status of the speed-position control switch mode	--	X2D			
Use prohibited* ²	X10 to X1F	X25 to X29			
		X2E, X2F			

*1 The XY number same as the AD70 can be used for the QD73A1 by setting "Empty 0 point" to the "Unused" area of the QD73A1 (first half slot: Empty 16 points) in I/O assignment of PLC parameter.

*2 A "Use prohibited" area is reserved for the system use and cannot be used by a user.

If it is turned on/off through a sequence program, the normal operation of the module cannot be guaranteed.

7.6.4 Buffer memory address comparison

Sequence program change is required because the assignment of buffer memory differs between the modules.

For details of the buffer memory or sequence program, refer to the MELSEC-Q QD73A1 Positioning Module User's Manual.

area shows the differences between the AD70 and the QD73A1.

Item		Buffer memory address		
		AD70	QD73A1	
Fixed parameter	Stroke limit upper limit	0 1	0 1	
	Stroke limit lower limit	2 3	2 3	
	Electronic gear	Numerator of command pulse multiplication	4	4
		Denominator of command pulse multiplication	5	5
	Variable parameter	Speed limit value	20 21	20 21
Acceleration time		22	22	
Deceleration time		23	23	
In-position range		24	24	
Positioning mode		25	25	
OPR data	OP address	40 41	40 41	
	OPR speed	42 43	42 43	
	Creep speed	44 45	44 45	
		Setting for the movement amount after near-point dog ON	46 47	46 47
	Positioning data	Positioning pattern	60	301
Positioning address P ₁		61 62	302 303	
Positioning speed V ₁		63 64	304 305	
		Positioning address P ₂	65 66	306 307
Positioning speed V ₂		67 68	308 309	
Control change area	New current value	80 81	80 81	
	New speed value	82 83	82 83	
	JOG speed (area)	84 85	84 85	
	Deviation counter clear command	86	86	
	Analog output adjustment area 1	87	87	
	New speed-position movement amount	88 89	88 89	
	Current value change request	--	90	
	Speed change request	--	91	
	Analog output adjustment area 2	--	92 93	

	Item	Buffer memory address	
		AD70	QD73A1
Zero/gain adjustment area	Zero/gain adjustment specification	--	94
	Zero/gain adjustment value specification	--	95
	Factory default zero/gain adjustment value restoration request	--	96
Monitor area	Current feed value	100	100
		101	101
	Actual current value	102	102
		103	103
	Error code (ERR.1)	104	104
	Error code (ERR.2)	105	105
	Deviation counter value	106	116 ^{*1}
		107	117 ^{*1}
	Deviation counter value (address)	--	106 ^{*2}
		--	107 ^{*2}
	Movement amount after near-point dog ON	108	108
		109	109
	Speed-position switching command	110	110
	Control mode	111	111
Zero/gain execution status	--	112	
Zero/gain adjustment status	--	113	
Feedrate	--	114	
	--	115	
Error history	(Record 0) Error code	--	120
	(Record 0) Error occurrence (Year : Month)	--	121
	(Record 0) Error occurrence (Day : Hour)	--	122
	(Record 0) Error occurrence (Minute : Second)	--	123
	(Record 1 to 15)	--	124 to 183
	Error history pointer	--	184

*1 A value of the same specification as AD70 is stored. The buffer memory address name of the QD73A1 changes Deviation counter value (pulse). Deviation counter value (pulse) supports the QD73A1 whose serial number (first five digits) is "15042" or later.

*2 When electronic gear setting is 1/1, the value will be the same as Deviation counter value (pulse).

7.6.5 Interface specifications comparison with external devices

For the external interface specifications, the following shows the differences between the AD70 and the QD73A1.

○ : Compatible, △ : Partial change required

Item	AD70	QD73A1	Compati- bility	Precautions for replacement
External power supply	+15VDC, 0.2A -15VDC, 0.02A	--	○	An external power supply terminal block is not available because an external power supply is not required.
External input signal	Servo READY	○	○	
	Stop signal	○	○	
	Near-point dog signal	○	○	
	Upper limit signal	○	○	
	Lower limit signal	○	○	
	Speed-position switching command	○	○	○
Positioning feedback pulse input	(Pulse frequency) Open collector: 100kpulse/s or less TTL: 100kpulse/s or less Differential: 100kpulse/s or less	(Pulse frequency) Open collector: 200kpulse/s or less TTL: 200kpulse/s or less Differential: 1Mpulse/s or less	○	The specification has improved. (Upward-compatibility)
Servo ON	○	○	○	
Speed command (analog signal)	○	○	○	

7.6.6 Precautions for the replacement of the AD70 by the QD73A1

The following shows precautions for the replacement of the AD70 by the QD73A1.

Item	AD70	QD73A1	Precautions
Number of occupied slots	1 slot	2 slots	*1
Number of occupied I/O points	32 points (I/O assignment: Special function module, 32 points)	48 points (I/O assignment: First half slot: Empty 16 points Second half slot: Intelli., 32 points)	*2
Buffer memory address	<ul style="list-style-type: none"> Addresses are partly changed. New items are added due to the specification change. 		*3
Mode setting	Hardware switch setting	Parameter setting of a CPU module ("I/O assignment" → "Switch setting")	*4
LED	<ul style="list-style-type: none"> Items indicated with the LEDs differ between the AD70 and the QD73A1. 		*5
External wiring	<ul style="list-style-type: none"> The existing connectors can be used. 		*6*7
Operation of when Servo READY signal is off	The AD70 counts the feedback pulse, and outputs the voltage proportional to the deviation counter.	The QD73A1 clears the deviation counter to 0, and outputs 0V.	*8

- *1 Note the following because the number of occupied slots increases for the QD73A1.
- 1) Check that the base unit has empty slots of 1 slot (or more).
If the base unit does not have an empty slot, an additional extension base unit is required.
 - 2) The module occupying 2 slots cannot be mounted on the Q series large type base unit.
Because the same base unit of the existing module is used for the QD73A1, when mounting the QD73A1 on the Q series large type base unit, use 2 base units by adding an extension base unit.
- *2 Configure the I/O assignment setting of parameters in either of following ways so that addresses of the QD73A1 remain the same as the AD70 even after the replacement.
- 1) Set Empty 0 point to the first half slot.
 - 2) Set the same address of the AD70 to the second half slot of the QD73A1 in the start XY setting.
- *3 Changes or corrections of the programs are required.
For details, refer to the MELSEC-Q QD73A1 Positioning Module User's Manual.
- *4 The method of mode setting, which is required for the positioning, is changed from a hardware switch to the switch setting in I/O assignment of PLC parameter.
Configure the same setting as the AD70 by referring to the MELSEC-Q QD73A1 Positioning Module User's Manual.
- *5 Items indicated with the LEDs can be checked with I/O signals of the QD73A1.
If necessary, install lamps corresponding to the LED indications externally and indicate the on/off status of the I/O signals using a program.
- *6 The position where a module is mounted is changed because the dimensions of a base unit of the QD73A1 differ.
Check whether the wiring is enough even after the replacement because the connector position is changed though the existing connectors can be used without the wiring change.

*7 When the AD70 being used in the setting that the positive voltage is output when the positioning address increases (slide switch 1 (rotation direction setting): on) is replaced with the QD73A1, the cables between the AD70 and an encoder can be used.

When the AD70 being used in the setting that the negative voltage is output when the positioning address increases (slide switch 1 (rotation direction setting): off) is replaced with the QD73A1, the wiring change between the AD70 and an encoder is required.

When the AD70 is replaced with the QD73A1 whose serial number (first five digits) is "15042" or later, the cables between the AD70 and the encoder can be used by changing the intelligent function module switch setting.

<Replacement with the QD73A1 whose serial number (first five digits) is "15041" or earlier>

- Change the wiring between the AD70 and the encoder so that each phase A and B is reversed.

No.	Slide switch 1 of the AD70 (rotation direction setting)	Rotation direction of the motor and encoder	Wiring between the AD70 and encoder	Wiring when the AD70 is replaced to the QD73A1
1	OFF	Same direction		
2		Reverse direction		

<Replacement with the QD73A1 whose serial number (first five digits) is "15042" or later>

- Set b0 (switch 3) of the intelligent function module switch to 1.

*8 The operation for the QD73A1 while the signal is off was changed from the operation for the AD70 due to the safety consideration of when Servo READY signal is turned on.

The QD73A1 whose serial number (first five digits) is "15042" or later operates the same as the AD70 by setting b4 (switch 3) of the intelligent function module switch to 1.

8 UPGRADE OF THE POSITION

8.1 A61LS

A61LS, the Mitsubishi position detection modules, is able to upgrade to VARILIMIT. VS-Q62B-V1PG manufactured by our partner "NSD Corporation".

VS-Q62B-V1PG is a built-in converter for Mitsubishi programmable controller Q series.

(1) **ABSOCODER sensor cable**

The existing cables can be reused. A new wiring is not necessary. I/O cables should be replaced because connectors are different.

The specifications are different between A61LS and VS-Q62B-V1PG, and the extensive modification is necessary in the sequence program and so on. Therefore, please contact your local Mitsubishi representative.

8.2 A62LS-S5 and A63LS

A62LS-S5 and A63LS, the Mitsubishi position detection modules, are able to upgrade to VARILIMIT "VS-Q62" or "VS-Q62B Series" manufactured by our partner "NSD Corporation".

VS-Q62/VS-Q62B Series are a built-in converter for Mitsubishi programmable controller Q series.

(1) Model list of the existing positioning modules, ABSOCODER sensors, and replacement modules

The replacement module "VS-Q62" is selected based on the existing position detection modules and ABSOCODER sensor models with using the below list.

ABSOCODER sensor	Replacement Q series		Existing A series positioning module		
	Positioning module	Position detection module	A62LS	A62LS-B5	A1S62LS
	VS-Q62	VS-Q62B			
MRE-32SP062SAC	VS-Q62-M2PG	VS-Q62B-M2PG	○	○	○
MRE-G□SP062FAC (□: 64/128/160/256/320)			○	○	○
VLS-256PWB	VS-Q62-L	-	○	○	-
VLS-512PWB			○	○	-
VLS-1024PW			○	○	-
VLS-512PYB			○	○	-
VLS-1024PYB			○	○	-
VLS-2048PY			○	○	-

VS-Q62: Positioning type with scaling, positioning, and switch output functions

VS-Q62B: Converter type with position detection function

ABSOCODER sensor	Replacement Q series		Existing A series positioning module
	Positioning module	Position detection module	A63LS
	VS-Q262	VS-Q262B	
MRE-32SP062SAC	VS-Q262-M2PG	VS-Q262B-M2PG	○
MRE-G□SP062FAC (□: 64/128/160/256/320)			○

VS-Q262: Positioning type with scaling, positioning, and switch output functions

VS-Q262B: Converter type with position detection function

(2) ABSOCODER sensor cable

The existing cables can be reused. A new wiring is not necessary. I/O cables should be replaced because connectors are different.

(3) Parameter setting software

Please select VS-Q62/Q262-EDW, the parameter setting software for VS-Q62 series.

	VS-Q62	VS-Q62B	A62LS	A62LS-S5	A63LS	A1S62LS
VS-T62	VS-Q62/Q262-EDW		-	-	○	○
Accessory	(Parameter setting software)		○	○	-	-

Please contact SG Corporation, Overseas division of NSD Group if you need the details of upgrading or VS-Q62 series.

Contact: SG Corporation, Overseas division

Tel: +81 (0) 52 261 2352

Fax: +81 (0) 52 252 0522

E-mail: foreign@nsdcorp.co.jp

9 EXTERNAL DIMENSIONS

9.1 External Dimensions

For external dimensions of modules shown in this handbook, refer to the Use's Manual for each module.
For external dimensions of base units shown in this handbook, refer to the following.

Handbook	Manual number
Transition from MELSEC-A/QnA (Large Type) Series to Q Series Handbook (Fundamentals)	L-08043ENG

APPENDICES

Appendix 1 Spare parts storage

- (1) The general specifications of programmable controllers are as follows. Please do not store spare parts under a high temperature or high humidity condition, even within the range guaranteed by the specifications.

Storage ambient temperature	-20 to 75°C
Storage ambient humidity	10 to 90%, no condensation

- (2) Store in a place avoiding direct sunlight.
- (3) Store under condition with less dust or no corrosive gas.
- (4) The battery capacity of a A6BAT battery or a lithium-coin battery (commercially available) for memory card will be decreased by its self-discharging even when not used. Replace it with new one in 5 years as a guideline.
- (5) For a power supply module, CPU module with built-in power supply, or analog module that use any aluminum electrolytic capacitor, which is indicated in the table below, take the following measures since the characteristics will be deteriorated when the aluminum electrolytic capacitor is left un-energized for a long time.

Product	Model
CPU module (Power supply built-in type)	A1NCP, A1NCPUP21, A1NCPUR21, A1NCPUP21-S3, A2CCPU, A2CCPUP21, A2CCPUR21, A2CCPUC24, A2CCPUC24-PRF, A2CJCPU-S3
Power supply module	A61P, A61PEU, A61P-UL, A62P, A62PEU, A63P, A68P, A61RP, A67RP, A2CJ66P
Analog module	A62DA, A62DA-S1

[Countermeasures for preventing aluminum electrolytic capacitor characteristics deterioration]

Apply the rated voltage to the aluminum electrolytic capacitor for several hours once a year to activate it. Or, rotate products at the periodic inspection (in every 1 year or two).

[Reference]

The life of an aluminum electrolytic capacitor, even if not used, under a normal temperature decreases approximately at 1/4 speed of the case when it is energized.

Appendix 2 Related Manuals

Appendix 2.1 Replacement Handbooks

(1) Transition Guide

No.	Manual Name	Manual Number	Model Code
1	MELSEC-A/QnA Series Transition Guide	L(NA)08077E	–

(2) Transition from MELSEC-A/QnA (large type) to Q series handbook

No.	Manual Name	Manual Number	Model Code
1	Transition from MELSEC-A/QnA (Large Type) Series to Q Series Handbook (Fundamentals)	L-08043ENG	–
2	Transition from MELSEC-A/QnA (Large Type) Series to Q Series Handbook (Intelligent Function Modules)	L-08046ENG	–
3	Transition from MELSEC-A/QnA (Large Type) Series to Q Series Handbook (Network Modules)	L-08048ENG	–
4	Transition from MELSEC-A/QnA (Large Type) Series to Q Series Handbook (Communications)	L-08050ENG	–
5	Transition from MELSEC-A0J2H Series to Q Series Handbook	L-08060ENG	–
6	Transition from MELSECNET/MINI-S3, A2C(I/O) to CC-Link Handbook	L-08061ENG	–
7	Transition from MELSEC-I/OLINK to CC-Link/LT Handbook	L-08062ENG	–
	Transition from MELSEC-I/OLINK to AnyWire DB A20 Handbook	L08263ENG	–
8	Transition from MELSEC-A/QnA Large Type Series to AnS/Q2AS Small Type Series Handbook	L-08064ENG	–
9	Transition of CPUs in MELSEC Redundant System Handbook (Transition from Q4ARCPU to QnPRHCPU)	L-08117ENG	–

(3) Transition Examples

No.	Manual Name	Manual Number	Model Code
1	MELSEC-A/QnA (Large), AnS/QnAS (Small) Transition Examples	L(NA)08121E	–

(4) Others

No.	Manual Name (TECHNICAL BULLETIN)	Manual Number	Model Code
1	Procedures for Replacing Positioning Module AD71 with QD75	FA-A-0060	
2	Precautions for replacing A/QnA (large type) series CPU with Universal model QCPU	FA-A-0068	–

Appendix 2.2 A/QnA series

No.	Manual name	Manual number	Model code
1	MELSEC-QnA/A Catalog	L-174-0-C5177	–
2	MELSEC-QnAS/AnS Catalog	L-174-0-C5266	–
3	Analog-Digital Converter Module Type A68AD User's Manual	IB-64572	13J305
4	Analog-Digital Converter Module Type A68AD-S2 User's Manual	IB-68102	13J349
5	Analog-Digital Converter Module Type A68ADN User's Manual	IB-68219	13JA33
6	Analog-Digital Converter Module Type A616AD User's Manual	IB-68078	13J361
7	Digital-Analog Converter Module Type A62DA User's Manual	IB-64573	13J306
8	Digital-Analog Converter Module Type A62DA-S1 User's Manual	IB-68074	13J350
9	Digital-Analog Converter Module Type A68DAV/A68DAI(S1) User's Manual	IB-68273	13JA35
10	Digital-Analog Converter Module Type A616DAV User's Manual	IB-68079	13J362
11	Digital-Analog Converter Module Type A616DAI User's Manual	IB-68080	13J363
12	Pt100 Input Module Type A68RD3N/4N, A1S62RD3N/4N User's Manual	SH-080190	13JT69
13	Temperature-Digital Converter Module Type A616TD User's Manual	IB-68104	13J368
14	High-Speed Counter Module Type AD61(AD61S1) User's Manual	IB-64576	13J307
15	Positioning Module Type AD70 User's Manual	IB-68106	13J356
16	Positioning Module Type AD72 User's Manual	IB-68008	13J333
17	Positioning Module Type A1SD75P1-S3/P2-S3/P3-S3 AD75P1-S3/P2-S3/P3-S3 User's Manual	SH-3608	13JH86
18	Positioning Module Type A1SD75M1/M2/M3 AD75M1/M2/M3 User's Manual	IB-66715	13JH85
19	GX Configurator-AP Version 1 Operating Manual	IB-80031	13JN44

Appendix 2.3 Q series

No.	Manual name	Manual number	Model code
1	MELSEC-Q Catalog	L-08033E	–
2	MELSEC-Q Data Book	L-08029E	–
3	Analog-Digital Converter Module User's Manual	SH-080055	13JR03
4	Channel Isolated High Resolution Analog-Digital Converter Module (With Signal Conditioning Function) User's Manual	SH-080277	13JR51
5	Digital-Analog Converter Module User's Manual	SH-080054	13JR02
6	Channel Isolated Digital-Analog Converter Module User's Manual	SH-080281	13JR52
7	Channel Isolated Analog-Digital Converter Module (With Signal Conditioning Function) User's Manual	SH-080647ENG	13JR96
8	Channel Isolated Thermocouple Input Module User's Manual	SH-080795ENG	13JZ26
9	Thermocouple Input Module Channel Isolated Thermocouple/Micro Voltage Input Module User's Manual	SH-080141	13JR30
10	RTD Input Module Channel Isolated RTD Input Module User's Manual	SH-080142	13JR31
11	High-Speed Counter Module User's Manual	SH-080036	13JL95
12	High-Speed Counter Module QD62-H01, QD62-H02 User's Manual	IB-0800421	13JY78
13	Type QD75P/QD75D Positioning Module User's Manual	SH-080058	13JR09
14	Type QD75M Positioning Module User's Manual	IB-0300062	1CT752
15	GX Configurator-QP Version 2 Operating Manual	SH-080172	13JU19
16	QD73A1 Positioning Module User's Manual	SH-081075ENG	13JZ69

Appendix 2.4 Programming tool

No.	Manual name	Manual number	Model code
1	GX Developer Version 8 Operating Manual	SH-080373E	13JU41

WARRANTY

Please confirm the following product warranty details before using this product.

1. Gratis Warranty Term and Gratis Warranty Range

If any faults or defects (hereinafter "Failure") found to be the responsibility of Mitsubishi occurs during use of the product within the gratis warranty term, the product shall be repaired at no cost via the sales representative or Mitsubishi Service Company.

However, if repairs are required onsite at domestic or overseas location, expenses to send an engineer will be solely at the customer's discretion. Mitsubishi shall not be held responsible for any re-commissioning, maintenance, or testing on-site that involves replacement of the failed module.

[Gratis Warranty Term]

The gratis warranty term of the product shall be for one year after the date of purchase or delivery to a designated place.

Note that after manufacture and shipment from Mitsubishi, the maximum distribution period shall be six (6) months, and the longest gratis warranty term after manufacturing shall be eighteen (18) months. The gratis warranty term of repair parts shall not exceed the gratis warranty term before repairs.

[Gratis Warranty Range]

- (1) The range shall be limited to normal use within the usage state, usage methods and usage environment, etc., which follow the conditions and precautions, etc., given in the instruction manual, user's manual and caution labels on the product.
- (2) Even within the gratis warranty term, repairs shall be charged for in the following cases.
 1. Failure occurring from inappropriate storage or handling, carelessness or negligence by the user. Failure caused by the user's hardware or software design.
 2. Failure caused by unapproved modifications, etc., to the product by the user.
 3. When the Mitsubishi product is assembled into a user's device, Failure that could have been avoided if functions or structures, judged as necessary in the legal safety measures the user's device is subject to or as necessary by industry standards, had been provided.
 4. Failure that could have been avoided if consumable parts (battery, backlight, fuse, etc.) designated in the instruction manual had been correctly serviced or replaced.
 5. Failure caused by external irresistible forces such as fires or abnormal voltages, and Failure caused by force majeure such as earthquakes, lightning, wind and water damage.
 6. Failure caused by reasons unpredictable by scientific technology standards at time of shipment from Mitsubishi.
 7. Any other failure found not to be the responsibility of Mitsubishi or that admitted not to be so by the user.

2. Onerous repair term after discontinuation of production

- (1) Mitsubishi shall accept onerous product repairs for seven (7) years after production of the product is discontinued.

Discontinuation of production shall be notified with Mitsubishi Technical Bulletins, etc.
- (2) Product supply (including repair parts) is not available after production is discontinued.

3. Overseas service

Overseas, repairs shall be accepted by Mitsubishi's local overseas FA Center. Note that the repair conditions at each FA Center may differ.

4. Exclusion of loss in opportunity and secondary loss from warranty liability

Regardless of the gratis warranty term, Mitsubishi shall not be liable for compensation of damages caused by any cause found not to be the responsibility of Mitsubishi, loss in opportunity, lost profits incurred to the user by Failures of Mitsubishi products, special damages and secondary damages whether foreseeable or not, compensation for accidents, and compensation for damages to products other than Mitsubishi products, replacement by the user, maintenance of on-site equipment, start-up test run and other tasks.

5. Changes in product specifications

The specifications given in the catalogs, manuals or technical documents are subject to change without prior notice.

Company and product names herein are either trademarks or registered trademarks of their respective owners.

Mitsubishi Programmable Controller



HEAD OFFICE : TOKYO BUILDING, 2-7-3 MARUNOUCHI, CHIYODA-KU, TOKYO 100-8310, JAPAN
NAGOYA WORKS : 1-14, YADA-MINAMI 5-CHOME, HIGASHI-KU, NAGOYA, JAPAN

When exported from Japan, this handbook does not require application to the Ministry of Economy, Trade and Industry for service transaction permission.